



JN5169

IEEE802.15.4 Wireless Microcontroller

Rev. 1.4 — 12 March 2020

Product data sheet

1. General description

The JN5169 is an ultra low power, high performance wireless microcontroller suitable for ZigBee applications. It features 512 KB embedded Flash, 32 kB RAM and 4 kB EEPROM memory, allowing OTA upgrade capability without external memory. The 32-bit RISC processor offers high coding efficiency through variable width instructions, a multi-stage instruction pipeline and low-power operation with programmable clock speeds. It also includes a 2.4 GHz IEEE802.15.4 compliant transceiver and a comprehensive mix of analog and digital peripherals. The best in class RX operating current (down to 13 mA and with a 0.7 μ A sleep timer mode) gives excellent battery life allowing operation direct from a coin cell. Radio transmit power is configurable up to +10 dBm output.

The peripherals support a wide range of applications. They include a 2-wire compatible I²C-bus and SPI-bus which can operate as either master or slave, a 6-channel ADC with a battery monitor and a temperature sensor. It can support a large switch matrix of up to 100 elements, or alternatively a 40-key capacitive touch pad.

2. Features and benefits

2.1 Benefits

- Single chip device to run stack and application
- Very low current solution for long battery life; over 10 years
- Very low RX current for low standby power of mains powered nodes
- Integrated power amplifier for long range and robust communication
- High tolerance to interference from other 2.4 GHz radio sources
- Supports multiple network stacks
- Highly featured 32-bit RISC CPU for high performance and low power
- Large embedded Flash memory to enable over-the-air firmware updates without external Flash memory
- System BOM is low in component count and cost
- Flexible sensor interfacing options
- Very thin quad flat 6 × 6 mm, 40 terminal package; lead-free and RoHS compliant
- Temperature range: -40 °C to +125 °C

2.2 Features: radio

- 2.4 GHz IEEE802.15.4 compliant
- RX current 14.7 mA, in low power receive mode 13 mA
- Receiver sensitivity -96 dBm
- Configurable transmit power, for example:



- ◆ 10 dBm, 23.3 mA
- ◆ 8.5 dBm, 19.6 mA
- ◆ 3 dBm, 14 mA
- Radio link budget 106 dB
- Maximum input level of +10 dBm
- Compensation for temperature drift of crystal oscillator frequency
- 128-bit AES security processor
- MAC accelerator with packet formatting, CRCs, address check, auto-acks, timers
- Integrated ultra low-power RC sleep oscillator (0.7 μ A)
- 2.0 V to 3.6 V battery operation
- Deep sleep current 50 nA (wake-up from IO)
- < 0.15 \$ external component cost
- Antenna diversity (Auto RX)

2.3 Features: microcontroller

- 32-bit RISC CPU; 1 MHz to 32 MHz clock speed
- Variable instruction width for high coding efficiency
- Multi-stage instruction pipeline
- 512 kB Flash
- 32 kB RAM
- 4 kB EEPROM
- Data EEPROM with guaranteed 100 k write operations
- ZigBee PRO stack with Home Automation, Light Link and Smart Energy profiles
- 2-wire I²C-bus compatible serial interface; can operate as either master or slave
- 5 \times PWM (4 timers, 1 timer/counter)
- 2 low-power sleep counters
- 2 UARTs
- SPI-bus master and slave port, 3 selects
- Supply voltage monitor with 8 programmable thresholds
- 6-input 10-bit ADC, comparator
- Battery and temperature sensors
- Watchdog and Supply Voltage Monitor (SVM)
- Up to 20 Digital IO (DIO) pins

3. Applications

- Robust and secure low-power wireless applications
- ZigBee 3.0
- Internet of Things (IoT)
- ZigBee Smart Energy networks
- ZigBee Light Link networks
- ZigBee Home Automation networks
- Toys and gaming peripherals
- Energy harvesting - for example, self-powered light switch

4. Overview

The JN5169 wireless microcontroller that provides a fully integrated solution for applications that use the IEEE802.15.4 standard in the 2.4 GHz to 2.5 GHz ISM frequency band, including ZigBee PRO applications based on the Smart Energy, Light Link and Home Automation profiles.

The JN5169 features 512 kB embedded Flash, 32 kB RAM and 4 kB EEPROM memory and radio outputs up to 10 dBm.

Applications that transfer data wirelessly tend to be more complex than applications for wired solutions. Wireless protocols make stringent demands on frequencies, data formats, timing of data transfers, security and other issues. Application development must consider the requirements of the wireless network in addition to the product functionality and user interfaces. To minimize this complexity, NXP provides a series of software libraries and interfaces that control the transceiver and peripherals of the JN5169. These libraries and interfaces remove the need for the developer to understand wireless protocols and greatly simplifies the programming complexities of power modes, interrupts and hardware functionality.

In view of the above, we do not provide the JN5169 register details in this data sheet.

The device includes a wireless transceiver, RISC CPU, on-chip memory and an extensive range of peripherals.

4.1 Wireless transceiver

The wireless transceiver comprises a 2.45 GHz radio, a modem, a baseband controller and a security coprocessor. In addition, the radio also provides an output to control transmit-receive switching of external devices such as power amplifiers allowing applications that require increased transmit power to be realized very easily. [Section 15.1](#) describes a complete reference design including Printed-Circuit Board (PCB) design and Bill Of Materials (BOM).

The security coprocessor provides hardware-based 128-bit AES-CCM modes as specified by the IEEE802.15.4 2006 standard. Specifically this includes encryption and authentication covered by the MIC-32/-64/-128, ENC and ENC-MIC-32/-64/-128 modes of operation.

The transceiver elements (radio, modem and baseband) work together to provide IEEE802.15.4 (2006) MAC and PHY functionality under the control of a protocol stack. Applications incorporating IEEE802.15.4 functionality can be developed rapidly by combining user-developed application software with a protocol stack library.

4.2 RISC CPU and memory

A 32-bit RISC CPU allows software to be run on-chip, its processing power being shared between the IEEE802.15.4 MAC protocol, other higher layer protocols and the user application. The JN5169 has a unified memory architecture. Code memory, data memory, peripheral devices and I/O ports are organized within the same linear address space. The device contains up to 512 kB of Flash, 32 kB of RAM and 4 kB EEPROM.

4.3 Peripherals

The following peripherals are available on chip:

- Master SPI-bus port with 3 select outputs
- Slave SPI-bus port
- 2 UARTs: one capable of hardware flow control (4-wire, includes RTS/CTS); the other just 2-wire (RX/TX)
- 1 programmable timer/counter which supports Pulse Width Modulation (PWM) and capture/compare, plus 4 PWM timers which support PWM and Timer modes only
- 2 programmable sleep timers and 1 tick timer
- 2-wire serial interface (compatible with SMBus and I²C-bus) supporting master and slave operation
- 20 digital I/O lines (multiplexed with peripherals such as timers, SPI-bus and UARTs)
- 2 digital outputs (multiplexed with SPI-bus port)
- 10-bit, Analog-to-Digital Converter (ADC) with up to 6 input channels
- Programmable analog comparator
- Internal temperature sensor and battery monitor
- 2 low-power pulse counters
- Random number generator
- Watchdog timer and Supply Voltage Monitor
- JTAG hardware debug port
- Transmit and receive antenna diversity with automatic receive switching based on received energy detection

User applications access the peripherals using the JN516x Integrated Peripherals API (Application Programming Interface). This allows applications to use a tested and easily understood view of the peripherals facilitating rapid system development.

5. Ordering information

Table 1. Ordering information

Type number	Product Description	Package			
		Name	Description	Version	Shipping Packaging
JN5169/001K	Zigbee and IEEE802.15.4 wireless microcontroller with 512 KB Flash, 32 KB RAM	HVQFN40	Plastic thermal enhanced very thin quad flat package; no leads; 40 terminals; body 6 × 6 × 0.85 mm	SOT618-8	TRAY-Tray, Bakeable, Multiple in Drypack
JN5169/001Y					REEL-Reel 13" Q1/T1 in Drypack
JN5169/001Z					REEL-Reel 7" Q1/T1 in Drypack

For further details, refer to the Wireless Connectivity area of the NXP web site [Ref. 1](#).

6. Block diagram

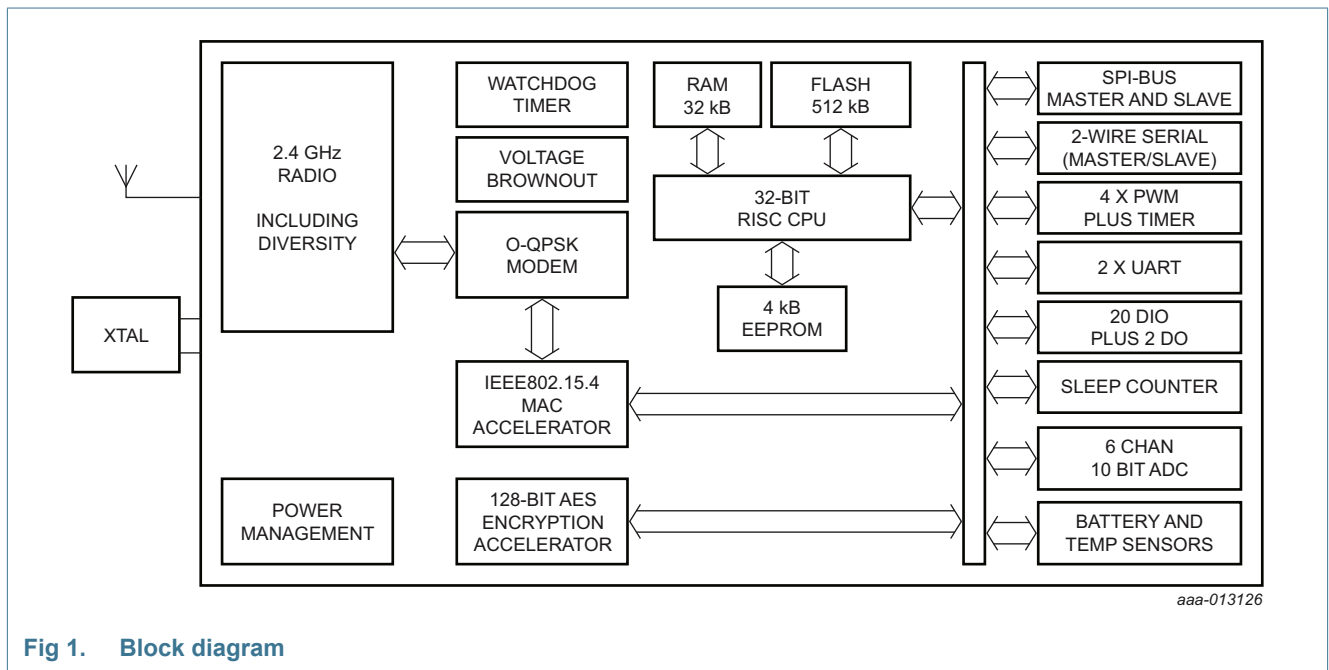
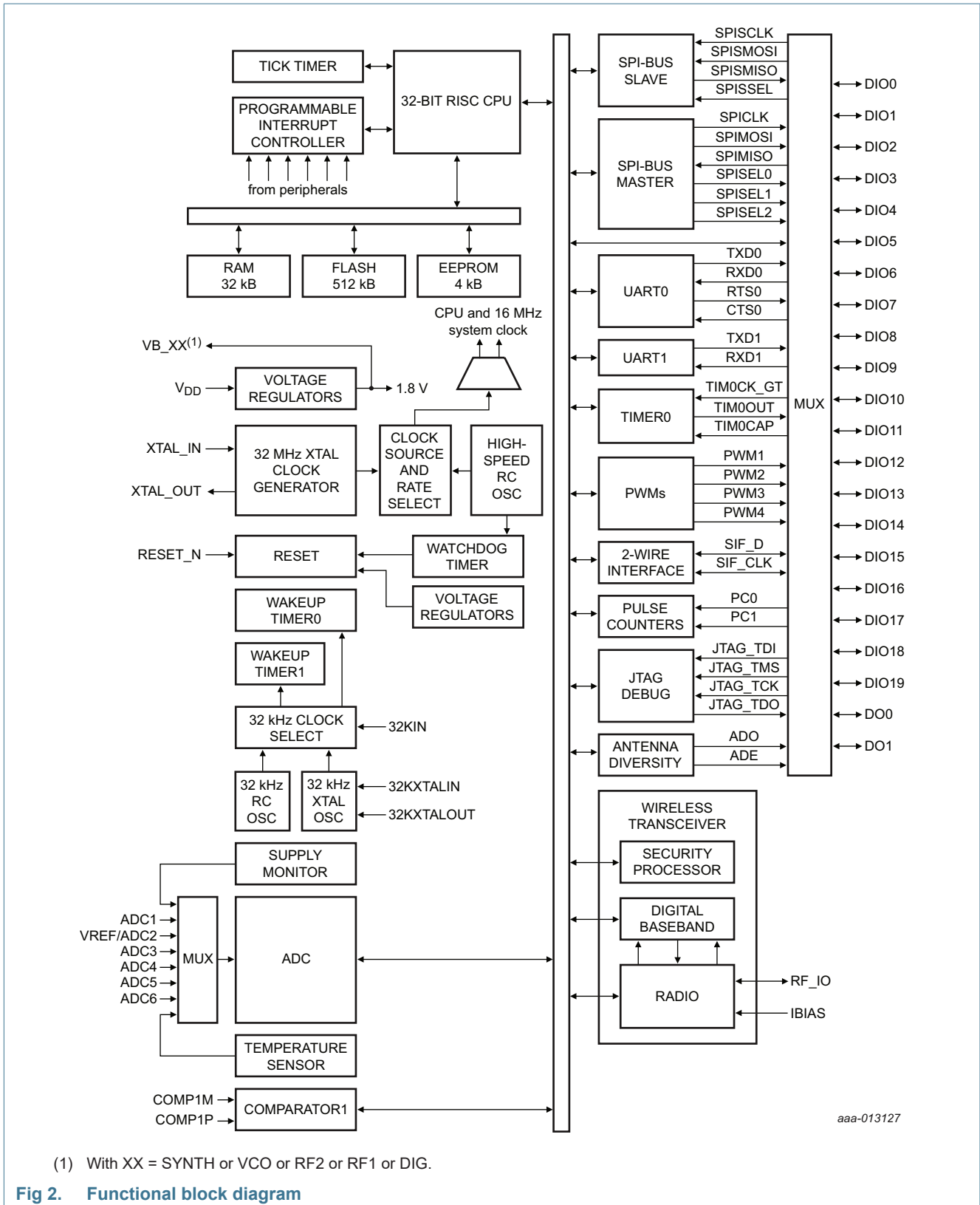

Fig 1. Block diagram

7. Functional diagram



8. Pinning information

8.1 Pinning

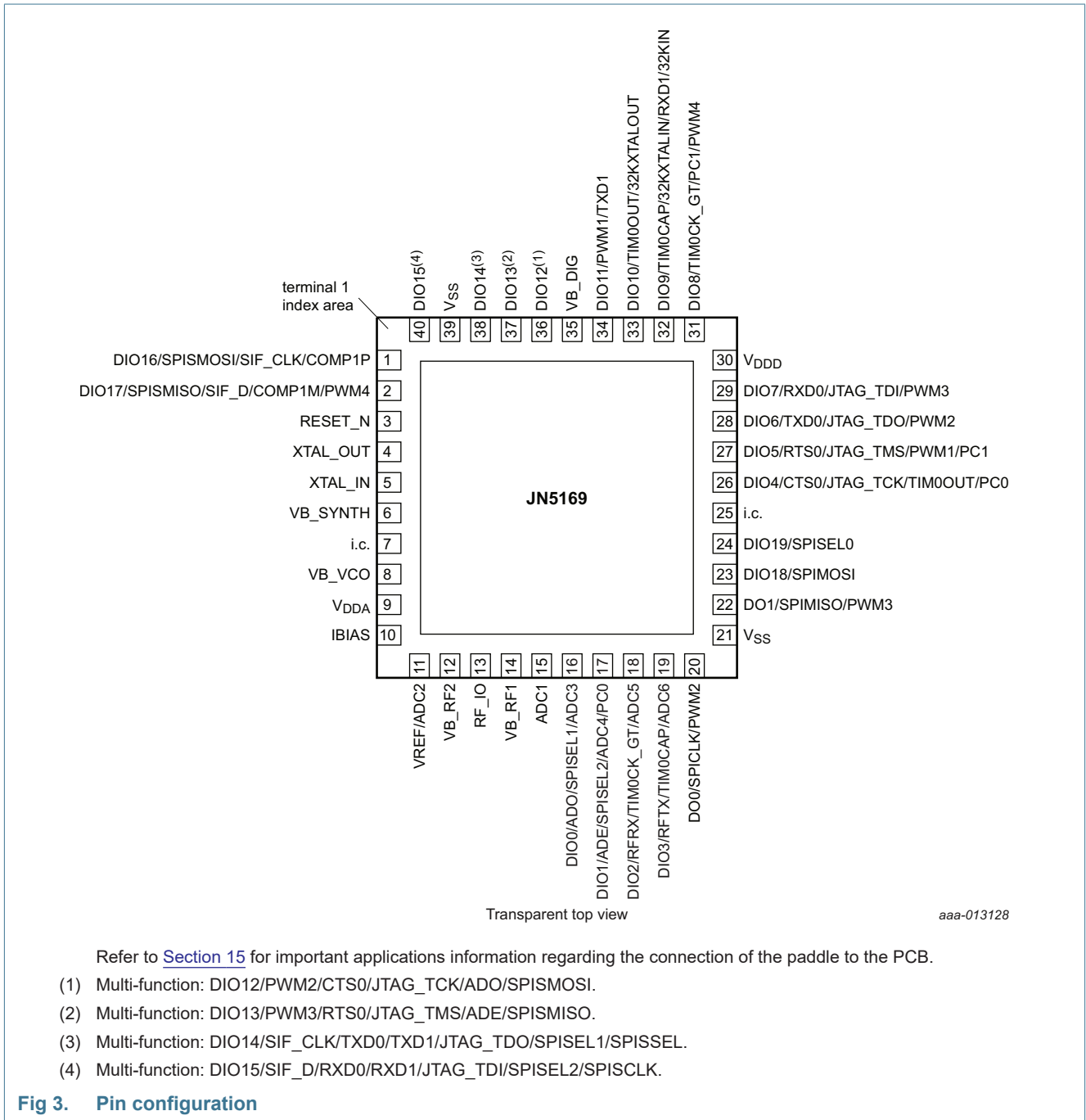

8.2 Pin description

Table 2. Pin description

Symbol	Pin	Type ^[1]	Description
DIO16/SPISMOSI/SIF_CLK/COMP1P	1	I/O	DIO16 — DIO16
			COMP1P — comparator plus input
			SIF_CLK — Serial Interface clock
			SPISMOSI — SPI-bus slave Master Out Slave In input
DIO17/SPISMISO/SIF_D/COMP1M/PWM4	2	I/O	DIO17 — DIO17
			COMP1M — comparator minus input
			SIF_D — Serial Interface Data
			SPISMISO — SPI-bus slave Master In Slave Out output
PWM4 — PWM 4 output			
RESET_N	3	I	RESET_N — reset input
XTAL_OUT	4	O	XTAL_OUT — system crystal oscillator
XTAL_IN	5	I	XTAL_IN — system crystal oscillator
VB_SYNT	6	P	VB_SYNT — regulated supply voltage
i.c.	7	-	internally connected; leave open
VB_VCO	8	P	VB_VCO — regulated supply voltage
V _{DDA}	9	P	V_{DDA} — analog supply voltage
IBIAS	10	I	IBIAS — bias current control
VREF/ADC2	11	P	VREF — analog peripheral reference voltage
		I	ADC2 — ADC input 2
VB_RF2	12	P	VB_RF2 — regulated supply voltage
RF_IO	13	I/O	RF_IO — RF antenna
VB_RF1	14	P	VB_RF1 — regulated supply voltage
ADC1	15	I	ADC1 — ADC input
DIO0/ADO/SPISEL1/ADC3	16	I/O	DIO0 — DIO0
			ADO — antenna diversity odd output
			SPISEL1 — SPI-bus master select output 1
			ADC3 — ADC input: ADC3
DIO1/ADE/SPISEL2/ADC4/PC0	17	I/O	DIO1 — DIO1
			ADE — antenna diversity even output
			SPISEL2 — SPI-bus master select output 2
			ADC4 — ADC input: ADC4
PC0 — pulse counter 0 input			
DIO2/RFRX/TIM0CK_GT/ADC5	18	I/O	DIO2 — DIO2
			RFRX — radio receiver control output
			TIM0CK_GT — timer0 clock/gate input
			ADC5 — ADC input: ADC5

Table 2. Pin description ...continued

Symbol	Pin	Type ^[1]	Description
DIO3/RFTX/TIM0CAP/ADC6	19	I/O	DIO3 — DIO3 RFTX — radio transmitter control output TIM0CAP — timer0 capture input ADC6 — ADC input: ADC6
DO0/SPICLK/PWM2 ^[2]	20	O	DO0 — DO0 SPICLK — SPI-bus master clock output PWM2 — PWM2 output
V _{SS}	21	GND	V_{SS} — ground
DO1/SPIMISO/PWM3 ^[3]	22	I/O	DO1 — DO1 SPIMISO — SPI-bus Master In, Slave Out input PWM3 — PWM3 output
DIO18/SPIMOSI	23	I/O	DIO18 — DIO18 SPIMOSI — SPI-bus Master Out Slave In output
DIO19/SPISEL0	24	I/O	DIO19 — DIO19 SPISEL0 — SPI-bus master Select Output 0
i.c.	25	-	internally connected; leave open
DIO4/CTS0/JTAG_TCK/TIM0OUT/PC0	26	I/O	DIO4 — DIO4 CTS0 — UART 0 clear to send input JTAG_TCK — JTAG CLK input TIM0OUT — timer0 PWM output PC0 — pulse counter 0 input
DIO5/RTS0/JTAG_TMS/PWM1/PC1	27	I/O	DIO5 — DIO5 RTS0 — UART 0 request to send output JTAG_TMS — JTAG mode select input PWM1 — PWM1 output PC1 — pulse counter 1 input
DIO6/TXD0/JTAG_TDO/PWM2	28	I/O	DIO6 — DIO6 TXD0 — UART 0 transmit data output JTAG_TDO — JTAG data output PWM2 — PWM2 data output
DIO7/RXD0/JTAG_TDI/PWM3	29	I/O	DIO7 — DIO7 RXD0 — UART 0 receive data input JTAG_TDI — JTAG data input PWM3 — PWM 3 data output
V _{DDD}	30	P	V_{DDD} — digital supply voltage
DIO8/TIM0CK_GT/PC1/PWM4	31	I/O	DIO8 — DIO8 TIM0CK_GT — timer0 clock/gate input PC1 — pulse counter1 input PWM4 — PWM 4 output

Table 2. Pin description ...continued

Symbol	Pin	Type ^[1]	Description
DIO9/TIM0CAP/32KXTALIN/RXD1/32KIN	32	I/O	DIO9 — DIO9 TIM0CAP — Timer0 Capture input 32KXTALIN — 32 kHz External Crystal input RXD1 — UART1 Receive Data input 32KIN — 32 kHz External clock input
DIO10/TIM0OUT/32KXTALOUT	33	I/O	DIO10 — DIO10 TIM0OUT — Timer0 PWM Output 32KXTALOUT — 32 kHz External Crystal output
DIO11/PWM1/TXD1	34	I/O	DIO11 — DIO11 PWM1 — PWM1 output TXD1 — UART1 Transmit Data output
VB_DIG	35	P	VB_DIG — regulated supply voltage
DIO12 ^[4]	36	I/O	DIO12 — DIO12 PWM2 — PWM2 output CTS0 — UART0 clear to send input JTAG_TCK — JTAG CLK input ADO — antenna diversity odd output SPISMO SI — SPI-bus slave Master Out, Slave In input
DIO13 ^[5]	37	I/O	DIO13 — DIO13 PWM3 — PWM3 output RTS0 — UART0 request to send output JTAG_TMS — JTAG mode select input ADE — antenna diversity even output SPISMISO — SPI-bus slave master in slave out output
DIO14 ^[6]	38	I/O	DIO14 — DIO14 SIF_CLK — serial interface clock TXD0 — UART 0 transmit data output TXD1 — UART 1 transmit data output JTAG_TDO — JTAG data output SPISEL1 — SPI-bus master select output 1 SPISEL — SPI-bus slave select input
V _{SS}	39	GND	V_{SS} — ground
DIO15 ^[7]	40	I/O	DIO15 — DIO15 SIF_D — serial interface data RXD0 — UART 0 receive data input RXD1 — UART 1 receive data input JTAG_TDI — JTAG data input SPISEL2 — SPI-bus master select output 2 SPISCLK — SPI-bus slave clock input
V _{SSA}	-	GND	V_{SSA} — Exposed die paddle

[1] P = power supply; G = ground; I = input, O = output; I/O = input/output.

- [2] JTAG programming mode: must be left floating high during reset to avoid entering JTAG programming mode.
- [3] UART programming mode: leave pin floating high during reset to avoid entering UART programming mode or hold it low to program.
- [4] Multi-function: DIO12/PWM2/CTS0/JTAG_TCK/ADO/SPISMOSI.
- [5] Multi-function: DIO13/PWM3/RTS0/JTAG_TMS/ADE/SPISMISO.
- [6] Multi-function: DIO14/SIF_CLK/TXD0/TXD1/JTAG_TDO/SPISEL1/SPISEL.
- [7] Multi-function: DIO15/SIF_D/RXD0/RXD1/JTAG_TDI/SPISEL2/SPISELCLK.

The PCB schematic and layout rules detailed in [Section 15.1](#) must be followed. Failure to do so will likely result in the JN5169 failing to meet the performance specification detailed in this data sheet and the worst case may result in the device not functioning in the end application.

8.2.1 Power supplies

The device is powered from the V_{DDA} and V_{DDD} pins, each being decoupled with a 100 nF ceramic capacitor. V_{DDA} is the power supply to the analog circuitry; it should be decoupled to ground. V_{DDD} is the power supply for the digital circuitry; it should also be decoupled to ground. In addition, a common 10 μ F tantalum capacitor is required for low frequencies. Decoupling pins for the internal 1.8 V regulators are provided with each pin requiring a 100 nF capacitor located as close to the device as practical. VB_SYNTH and VB_DIG require only a 100 nF capacitor. VB_RF1 and VB_RF2 should be connected together as close to the device as practical, and require one 100 nF capacitor and one 47 pF capacitor. The pin VB_VCO requires a 10 nF capacitor. See [Figure 48](#) for a schematic diagram.

V_{SSA} and V_{SS} are the ground pins.

Users are strongly discouraged from connecting their own circuits to the 1.8 V regulated supply pins, as the regulators have been optimized to supply only enough current for the internal circuits.

Rising V_{DD} voltage at power-up has to be done within 100 ms with a minimum I_{DD} current of 20 mA to avoid any start up issue.

8.2.2 Reset

RESET_N is an active-low reset input pin that is connected to a 500 k Ω internal pull-up resistor. It may be pulled low by an external circuit. See [Section 9.4.2](#) for more details.

8.2.3 32 MHz oscillator

A crystal is connected between XTAL_IN and XTAL_OUT to form the reference oscillator, which drives the system clock. A capacitor to analog ground is required on each of these pins. See [Section 9.3.1](#) for more details. The 32 MHz reference frequency is divided down to 16 MHz and this is used as the system clock throughout the device.

8.2.4 Radio

The radio is a single-ended design, requiring two capacitors and just two inductors to match the 50 Ω microstrip line to the RF_IO pin. In addition, extra-components are added on the line for filtering purpose.

An external resistor (43 k Ω) is required between IBIAS and analog ground (paddle) to set various bias currents and references within the radio.

8.2.5 Analog peripherals

The ADC requires a reference voltage to use as part of its operation. It can use either an internal reference voltage or an external reference connected to VREF. This voltage is referenced to analog ground and the performance of the analog peripherals is dependent on the quality of this reference.

There are 6 ADC inputs and a pair of comparator inputs. ADC1 has a designated input pin but ADC2 uses the same pin as VREF, invalidating its use as an ADC pin when an external reference voltage is required. The remaining 4 ADC channels are shared with the digital I/Os DIO0, DIO1, DIO2 and DIO3. When these 4 ADC channels are selected, the corresponding DIOs must be configured as inputs with their pull-ups disabled. Similarly, the comparator shares pins 1 and 2 with DIO16 and DIO17, so when the comparator is selected these pins must be configured as inputs with their pull-ups disabled. The analog I/O pins on the JN5169 can have signals applied up to 0.3 V higher than V_{DDA} . A schematic view of the analog I/O cell is shown in [Figure 4](#). [Figure 5](#) demonstrates a special case, where a digital I/O pin doubles as an input to analog devices. This applies to ADC3, ADC4, ADC5, ADC6, COMP1P and COMP1M.

In reset, sleep and deep sleep, the analog peripherals are all OFF. In sleep, the comparator may optionally be used as a wake-up source.

On platform with higher power (e.g. light Bulb, Smart Plug), unused ADC and comparator inputs should not be left unconnected, but connected to analog ground.

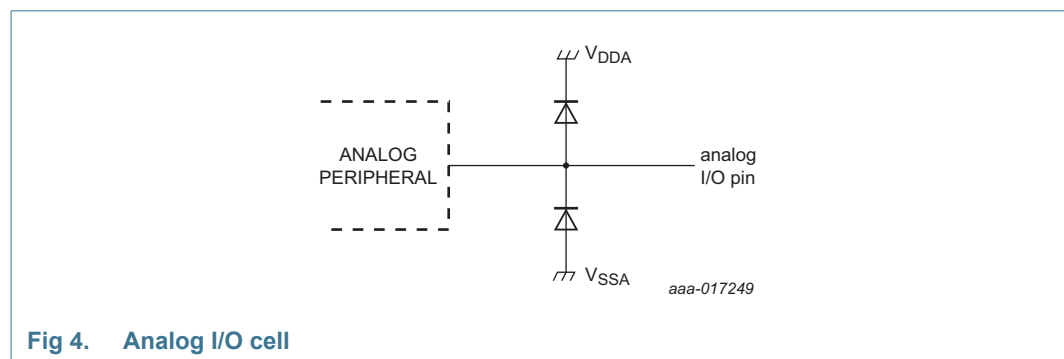

8.2.6 Digital Input/Output

For the DC properties of these pins, see [Section 14.2](#). When used in their primary function, all Digital Input/Output pins are bidirectional and are connected to weak internal pull-up resistors (50 k Ω nominal) that can be disabled. When used in their secondary function (selected when the appropriate peripheral block is enabled through software library calls), their direction is fixed by the function. The pull-up resistor is enabled or disabled independently of the function and direction; the default state from reset is enabled.

A schematic view of the Digital I/O cell shown in [Figure 5](#). The dotted lines through resistor R_{ESD} represent a path that exists only on DIO0, DIO1, DIO2, DIO3, DIO16 and DIO17 which are also inputs to the ADC (ADC3, ADC4, ADC5 and ADC6) and Comparator (COMP1P and COMP1M) respectively. To use these DIO pins for their analog functions, the DIO must be set as an input with its pull-up resistor, R_{PU} , disabled.

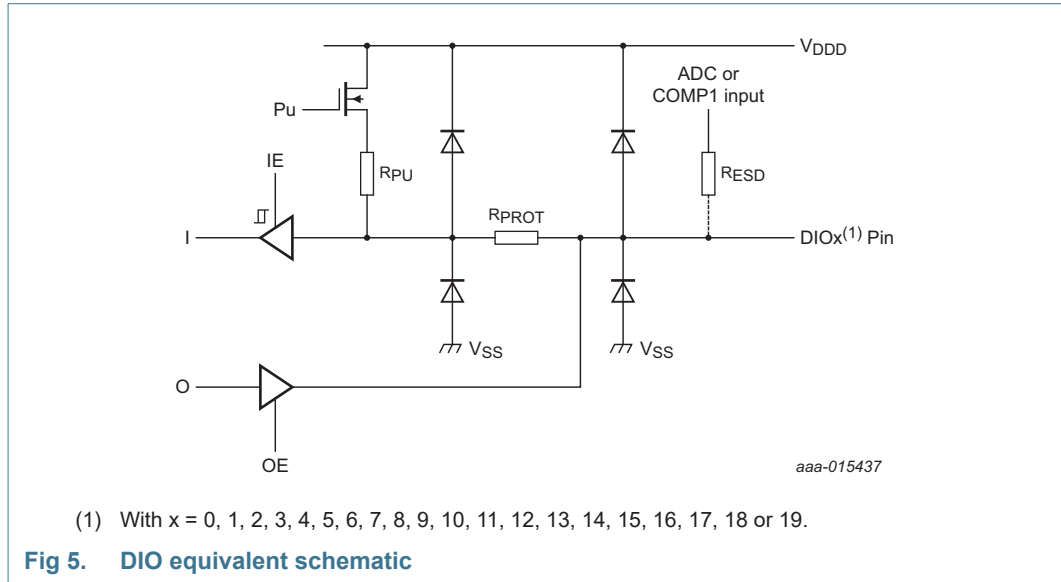

In reset, the digital peripherals are all off and the DIO pins are set as high-impedance inputs. During sleep and deep sleep, the DIO pins retain both their input/output state and the output level that was set at the start of sleep. If the DIO pins were enabled as inputs and the interrupts were enabled, then these pins may be used to wake up the JN5169 from sleep.

9. Functional description

9.1 CPU

The CPU of the JN5169 is a 32-bit load and store RISC processor. It has been architected for 3 key requirements:

- Low power consumption for battery powered applications
- High performance to implement a wireless protocol at the same time as complex applications
- Efficient coding of high-level languages such as C provided with the Software Developer's Kit

It features a linear 32-bit logical address space with unified memory architecture, accessing both code and data in the same address space. Registers for peripheral units, such as the timers, UART and the baseband processor, are also mapped into this space.

The CPU has access to a block of 15 × 32-bit General-Purpose (GP) registers together with a small number of special purpose registers which are used to store processor state and control interrupt handling. The contents of any GP register can be loaded from or stored to memory. Arithmetic and logical operations, shift and rotate operations, and signed and unsigned comparisons can be performed either between two registers and stored in a third, or between registers and a constant carried in the instruction. Operations between general or special-purpose registers execute in one cycle while those that access memory requires a further cycle to allow the memory to respond.

The instruction set manipulates 8-bit, 16-bit and 32-bit data; this means that programs can use objects of these sizes very efficiently. Manipulation of 32-bit quantities is particularly useful for protocols and high-end applications allowing algorithms to be implemented in fewer instructions than on smaller word-size processors, and allowing execution in fewer clock cycles. In addition, the CPU supports hardware Multiply that can be used to efficiently implement algorithms needed by Digital Signal Processing applications.

The instruction set is designed for the efficient implementation of high-level languages such as C. Access to fields in complex data structures is very efficient due to the provision of several addressing modes, together with the ability to use any of the GP registers to contain the address of objects. Subroutine parameter passing is also made more efficient by using GP registers rather than pushing objects onto the stack. The recommended programming method for the JN5169 is to use C, which is supported by a software developer kit comprising a C compiler, linker and debugger.

The CPU architecture also contains features that make the processor suitable for embedded, real-time applications. In some applications, it may be necessary to use a real-time operating system to allow multiple tasks to run on the processor. To provide protection for device-wide resources being altered by one task and affecting another, the processor can run in either supervisor or user mode, the former allowing access to all processor registers, while the latter only allows the GP registers to be manipulated. Supervisor mode is entered on reset or interrupt; tasks starting up would normally run in user mode in an RTOS environment.

Embedded applications require efficient handling of external hardware events. Exception processing (including reset and interrupt handling) is enhanced by the inclusion of a number of shadow registers into which the PC and status register contents are copied as part of the operation of the exception hardware. This means that the essential registers for exception handling are stored in one cycle, rather than the slower method of pushing them onto the processor stack. The PC is also loaded with the vector address for the exception that occurred, allowing the handler to start executing in the next cycle.

To improve power consumption, a number of power-saving modes are implemented in the JN5169, described more fully in [Section 10](#). One of these modes is the CPU doze mode; under software control, the processor can be shut down and on an interrupt it will wake up to service the request. Additionally, it is possible under software control to set the speed of the CPU to 1 MHz, 2 MHz, 4 MHz, 8 MHz, 16 MHz or 32 MHz. This feature can be used to trade off processing power against current consumption.

9.2 Memory organization

This section describes the different memories found within the JN5169. The device contains Flash, RAM and EEPROM memory, the wireless transceiver and peripherals all within the same linear address space.

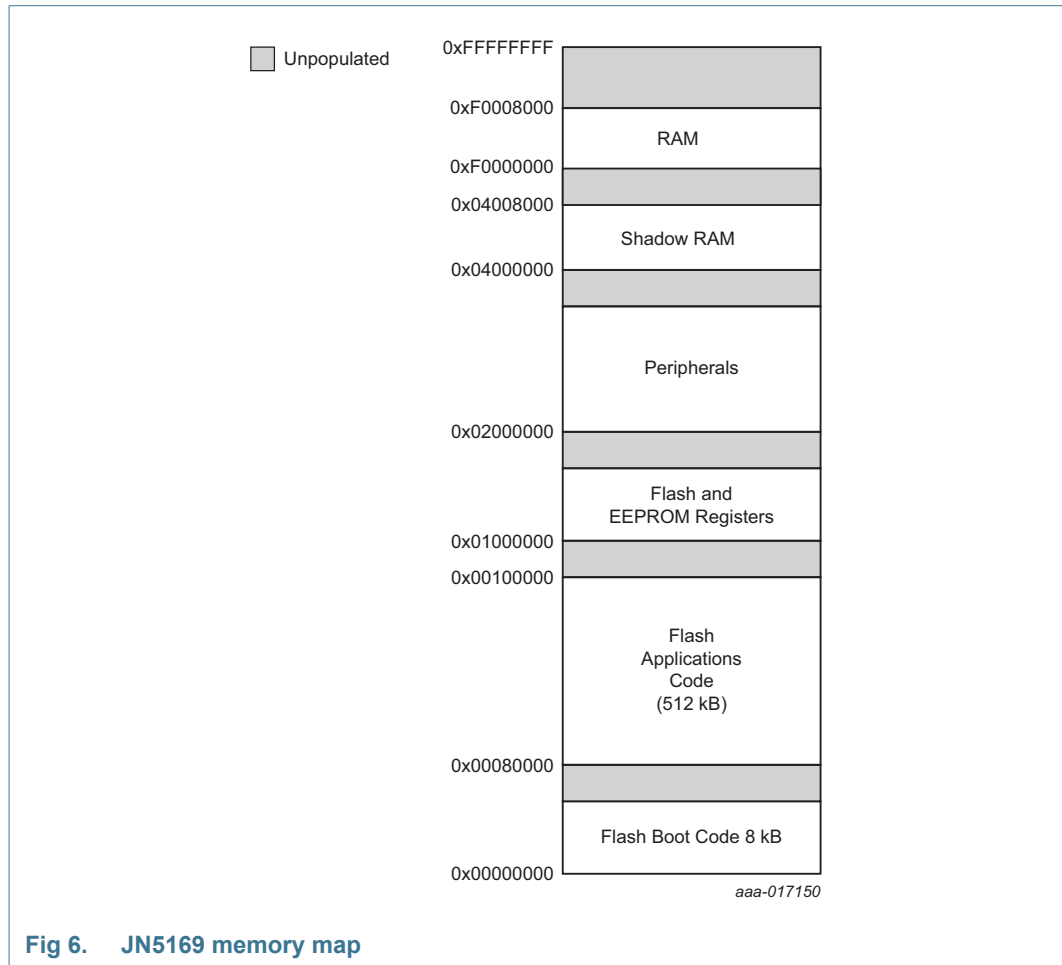

9.2.1 Flash

The embedded Flash consists of 2 parts: an 8 kB region used for holding boot code and a 512 kB region used for application code. The maximum number of write cycles or endurance is 10 k guaranteed, and typically 50 k, while the data retention is guaranteed for at least 10 years. The boot code region is pre-programmed by NXP on supplied parts and contains code to handle reset, interrupts and other events (see [Section 6](#)). It also contains a Flash Programming interface to allow interaction with the PC-based Flash programming utility which allows user code compiled using the supplied toolchain to be programmed into the Application space. For further information, see the Application Note on the Wireless Connectivity area of the NXP web site [Ref. 1](#).

9.2.2 RAM

The JN5169 devices contain 32 kB of high-speed RAM, which can be accessed by the CPU in a single clock cycle. It is primarily used to hold the CPU Stack together with program variables and data. If necessary, the CPU can execute code contained within the RAM (although it would normally just execute code directly from the embedded Flash). Software can control the power supply to the RAM allowing the contents to be maintained during a sleep period when other parts of the device are unpowered, allowing a quicker resumption of processing once woken.

9.2.3 OTP configuration memory

The JN5169 devices contain a quantity of One Time Programmable (OTP) memory as part of the embedded Flash (Index Sector). This can be used to securely hold such things as a user 64-bit MAC address and a 128-bit AES security key. A limited number of further bits are available for customer use for storage of configuration or other information. By default, the 64-bit MAC address is pre-programmed by NXP on supplied parts; however, customers can use their own MAC address and override the default one. The user MAC address and other data can be written to the OTP memory using the Flash programmer. Details on how to obtain and install MAC addresses can be found in the dedicated Application Note.

For further information on how to program and use this facility, see BeyondStudio for NXP User Guide (JN-UG-3098) on the Wireless Connectivity area of the NXP web site [Ref. 1](#).

9.2.4 EEPROM

The JN5169 devices contain 4 kB of EEPROM. The maximum number of write cycles or endurance is 100 k guaranteed, and 500 k typically, while the data retention is guaranteed for at least 10 years. This non-volatile memory is primarily used to hold persistent data generated from such things as the network stack software component (for example network topology, routing tables). As the EEPROM holds its contents through sleep and reset events, more stable operation and faster recovery is possible after outages. Access to the EEPROM is via registers mapped into the Flash and EEPROM registers region of the address map.

The customer may use part of the EEPROM to store their own data by interfacing with the Persistent Data Manager (PDM). Optionally, the PDM can also store data in an external memory. For further information, see the Wireless Connectivity area of the NXP web site [Ref. 1](#).

9.2.5 External memory

An optional external serial non-volatile memory (for instance Flash or EEPROM) with a SPI-bus interface may be used to provide additional storage for program code, such as a new code image or further data for the device when external power is removed. The memory can be connected to the SPI-bus master interface using select line SPISEL0 (see [Figure 7](#) for details).

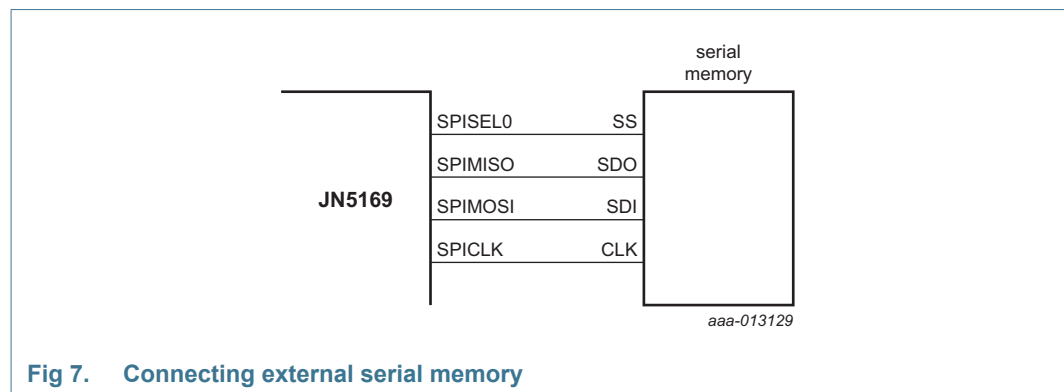

Fig 7. Connecting external serial memory

The contents of the external serial memory may be encrypted. The AES security processor combined with a user programmable 128-bit encryption key is used to encrypt the contents of the external memory. The encryption key is stored in the Flash memory

index sector. When bootloading program code from external serial memory, the JN5169 automatically accesses the encryption key to execute the decryption process. The user program code does not need to handle any of the decryption processes; it is transparent. For more details, including the how the program code encrypts data for the external memory, see the Application Note *JN51xx Boot Loader Operation (JN-AN-1003)* on the Wireless Connectivity area of the NXP web site [Ref. 1](#).

9.2.6 Peripherals

All peripherals have their registers mapped into the memory space. Access to these registers requires three peripheral clock cycles. Applications have access to the peripherals through the software libraries that present a high-level view of the peripheral's functions through a series of dedicated software routines. These routines provide both a tested method for using the peripherals and allow bug-free application code to be developed more rapidly. For details, see *JN516x Integrated Peripherals API User Guide (JN-UG-3087)* on the Wireless Connectivity area of the NXP web site [Ref. 1](#).

9.2.7 Unused memory address

Any attempt to access an unpopulated memory area will result in a bus error exception (interrupt) being generated.

9.3 System clocks

Two system clocks are used to drive the on-chip subsystems of the JN5169. The wake-up timers are driven from a low frequency clock (notionally 32 kHz). All other subsystems (transceiver, processor, memory and digital and analog peripherals) are driven by a high-speed clock (notionally 32 MHz), or a divided-down version of it.

The high-speed clock is either generated by the accurate crystal-controlled oscillator (32 MHz) or the less accurate high-speed RC oscillator (27 MHz to 32 MHz calibrated). The low-speed clock is either generated by the accurate crystal-controlled oscillator (32 kHz to 768 kHz), the less accurate RC oscillator (centered on 32 kHz) or can be supplied externally.

9.3.1 High-speed (32 MHz) system clock

The selected high-speed system clock is used directly by the radio subsystem, whereas a divided-by-two version is used by the remainder of the transceiver and the digital and analog peripherals. The direct or divided-down version of the clock is used to drive the processor and memories (32 MHz, 16 MHz, 8 MHz, 4 MHz, 2 MHz or 1 MHz).

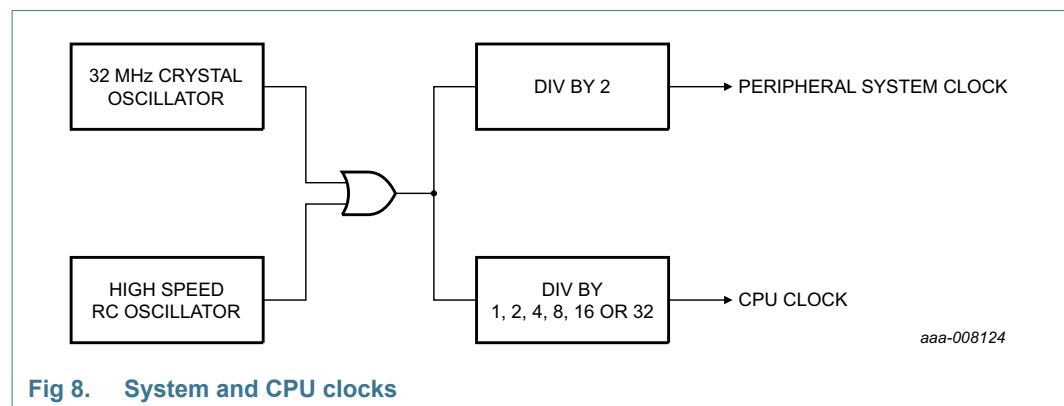

Crystal oscillators are generally slow to start. Hence to provide a fast start-up following a sleep cycle or reset, the fast RC oscillator is always used as the initial source for the high-speed system clock. The oscillator starts very quickly and will run at 25 MHz to 32 MHz (uncalibrated) or 32 MHz $\pm 5\%$ (calibrated). Although this means that the system clock will be running at an undefined frequency (slightly slower or faster than nominal), this does not prevent the CPU and Memory subsystems operating normally, so the program code can execute. However, it is not possible to use the radio or UARTs, as even after calibration (initiated by the user software calling an API function) there is still a $\pm 5\%$ tolerance in the clock rate over voltage and temperature. Other digital peripherals can be used (e.g. SPI-bus master/slave), but care must be taken if using timers due to the clock frequency inaccuracy.

Further details of the high-speed RC oscillator can be found in [Section 9.3.1.2](#)

On wake-up from sleep, the JN5169 uses the fast RC oscillator. It can then either:

- Automatically switch over to use the 32 MHz clock source when it has started up
- Continue to use the fast RC oscillator until software triggers the switch-over to the 32 MHz clock source - for example, when the radio is required
- Continue to use the RC oscillator until the device goes back into one of the sleep modes

The use of the fast RC oscillator at wake-up means that there is no need to wait for the 32 MHz crystal oscillator to stabilize. Consequently, the application code will start executing quickly using the clock from the high-speed RC oscillator.

9.3.1.1 32 MHz crystal oscillator

The JN5169 contains the necessary on-chip components to build a 32 MHz reference oscillator with the addition of an external crystal resonator and two tuning capacitors. The schematic of these components is shown in [Figure 8](#). The two capacitors, C1 and C2, should typically be 12 pF and use a C0G dielectric. Due to the small size of these capacitors, it is important to keep the traces to the external components as short as possible. The on-chip transconductance amplifier is compensated for temperature variation and is self-biasing by means of the internal resistor R1. This oscillator provides the frequency reference for the radio and therefore it is essential that the reference PCB layout and BOM are carefully followed. The oscillator includes a function which flags when the amplitude of oscillation has reached a satisfactory level for full operation, and this is checked before the source of the high-speed system clock is changed to the 32 MHz crystal oscillator.

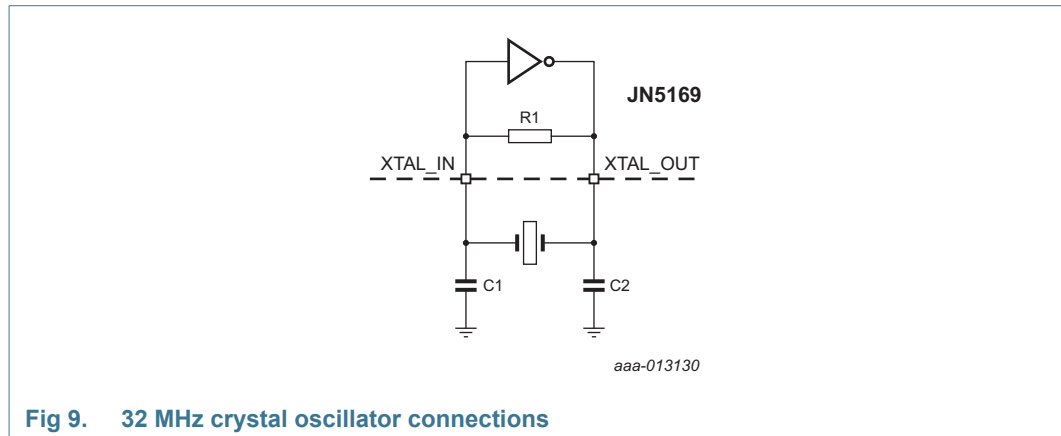

Fig 9. 32 MHz crystal oscillator connections

9.3.1.2 High-speed RC oscillator

An on-chip high-speed RC oscillator is provided in addition to the 32 MHz crystal oscillator for two purposes; to allow a fast start-up from reset or sleep and to provide a lower current alternative to the crystal oscillator for non-timing critical applications. By default the oscillator will run at 27 MHz, typically, with a wide tolerance. It can be calibrated, using a software API function, which will result in a nominal frequency of 32 MHz with a $\pm 1.6\%$ tolerance at 3 V and 25 °C. However, it should be noted that over the full operating range of voltage and temperature this will increase to $\pm 5\%$. The calibration information is retained through speed cycles and when the oscillator is disabled, so typically the calibration function only needs to be called once. No external components are required for this oscillator. The electrical specification of the oscillator can be found in [Section 14.3.9](#).

9.3.2 Low-speed (32 kHz) system clock

The 32 kHz system clock is used for timing the length of a sleep period (see [Section 10](#)). The clock can be selected from one of three sources through the application software:

- 32 kHz RC oscillator
- 32 kHz crystal oscillator
- 32 kHz external clock

Upon a chip reset or power-up, the JN5169 defaults to using the internal 32 kHz RC oscillator. If another clock source is selected, then it will remain in use for all 32 kHz timing until a chip reset is performed.

9.3.2.1 32 kHz RC oscillator

The internal 32 kHz RC oscillator requires no external components. The internal timing components of the oscillator have a wide tolerance due to manufacturing process variation and so the oscillator runs nominally at 32 kHz $-10\% +40\%$. To make this useful as a timing source for accurate wake-up from sleep, a frequency calibration factor derived from the more accurate 16 MHz clock may be applied. The calibration factor is derived through software; details can be found in [Section 9.9.9](#). Software must check that the 32 kHz RC oscillator is running before using it. The oscillator has a default current consumption of around 0.5 μA . Optionally, this can be reduced to 0.375 μA . However, the calibrated accuracy and temperature coefficient will be worse as a consequence.

9.3.2.2 32 kHz crystal oscillator

In order to obtain more accurate sleep periods, the JN5169 contains the necessary on-chip components to build a 32 kHz oscillator with the addition of an external 32.768 kHz crystal and two tuning capacitors. The crystal should be connected between 32KXTALIN and 32KXTALOUT (DIO9 and DIO10), with two equal capacitors to ground, one on each pin. Due to the small size of the capacitors, it is important to keep the traces to the external components as short as possible.

The electrical specification of the oscillator can be found in [Section 14.3.9](#). The oscillator cell is flexible and can operate with a range of commonly available 32.768 kHz crystals with load capacitances from 6 pF to 12.5 pF. However, the maximum ESR of the crystal and the supply current are both functions of the actual crystal used.

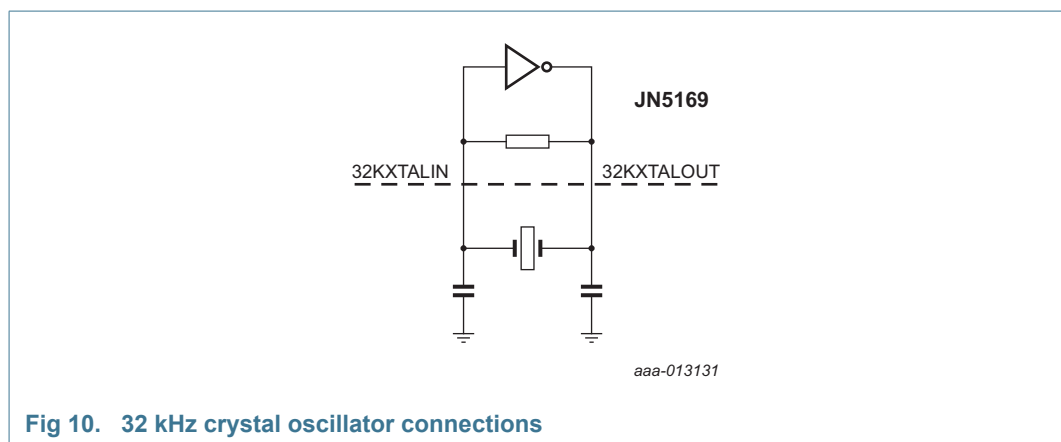

Fig 10. 32 kHz crystal oscillator connections

9.3.2.3 32 kHz external clock

An externally supplied 32 kHz reference clock on the 32KIN input (DIO9) may be provided to the JN5169. This would allow the 32 kHz system clock to be sourced from a very stable external oscillator module, allowing more accurate sleep cycle timings compared to the internal RC oscillator.

9.4 Reset

A system reset initializes the device to a pre-defined state and forces the CPU to start program execution from the reset vector. The reset process that the JN5169 goes through is as follows.

When power is first applied or when the external reset is released, the high-speed RC oscillator and 32 MHz crystal oscillator are activated. After a short wait period (approximately 13 μ s) while the high-speed RC starts up, and as long as the supply voltage satisfies the default Supply Voltage Monitor (SVM) threshold (2.0 V + 0.045 V hysteresis), the internal 1.8 V regulators are turned on to power the processor and peripheral logic. The regulators are allowed to stabilize (about 15 μ s) followed by a further wait (approximately 150 μ s) to allow the Flash and EEPROM bandgaps to stabilize and allow their initialization, including reading the user SVM threshold from the Flash. This is applied to the SVM, and after a brief pause (approximately 2.5 μ s) the SVM is checked again. If the supply is above the new SVM threshold, the CPU and peripheral logic are released from reset and the CPU starts to run code beginning at the reset vector. This runs the bootloader code contained within the Flash, which looks for a valid application to run, first from the internal Flash and then from any connected external serial memory over

the SPI-bus master interface. Once found, required variables are initialized in RAM before the application is called at its AppColdStart entry point. For more details on the bootloader, see the Application Note on the Wireless Connectivity area of the NXP web site [Ref. 1](#).

The JN5169 has 5 sources of reset:

- Internal Power-On Reset/Brown-Out Reset (BOR)
- External reset
- Software reset
- Watchdog timer
- Supply voltage detect

Remark: When the device exits a reset condition, device operating parameters (voltage, frequency, temperature, etc.) must be met to ensure operation. If these conditions are not met, then the device must be held in reset until the operating conditions are met (see [Section 14.3.1](#))

9.4.1 Internal Power-On Reset/Brown-Out Reset (BOR)

For the majority of applications, the Internal Power-On Reset is capable of generating the required reset signal. When power is applied to the device, the Power-On Reset circuit monitors the rise of the V_{DD} supply. When the V_{DD} reaches the specified threshold, the reset signal is generated. This signal is held internally until the power supply and oscillator stabilization time has elapsed, when the internal reset signal is then removed and the CPU is allowed to run.

The BOR circuit has the ability to reject spikes on the V_{DD} rail to avoid false triggering of the reset module. Typically for a negative going square pulse of duration $1\ \mu\text{s}$, the voltage must fall to $1.2\ \text{V}$ before a reset is generated. Similarly for a triangular wave pulse of $10\ \mu\text{s}$ width, the voltage must fall to $1.3\ \text{V}$ before causing a reset. The exact characteristics are complex and these are only examples. See [Figure 42](#) for more details on BOR and SVM characteristics.

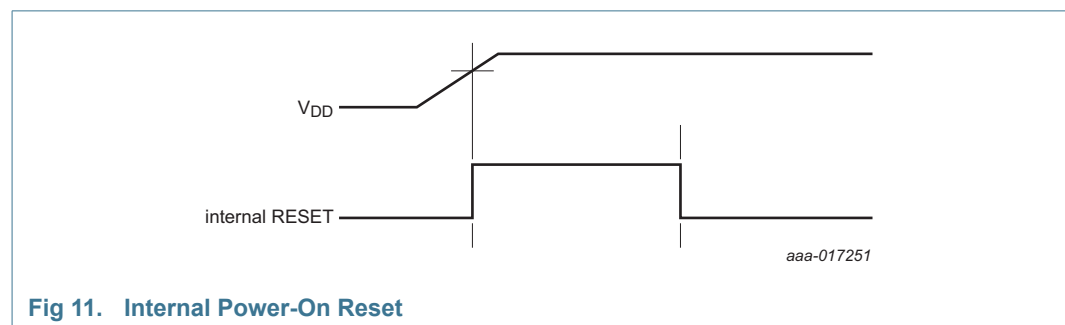

Fig 11. Internal Power-On Reset

When the supply drops below the POR 'falling' threshold, it will retrigger the reset. On platform with higher power (e.g. light bulb, smart plug) it is recommended to use this external circuit to avoid unexpected reset due to spurs.

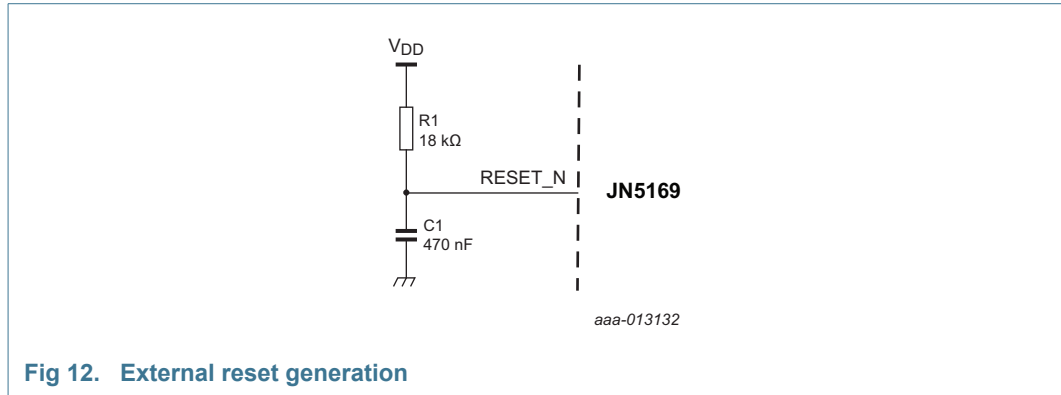

Fig 12. External reset generation

The external resistor and capacitor provide a simple reset operation when connected to the RESET_N pin but are not necessary.

9.4.2 External reset

An external reset is generated by a low level on the RESET_N pin. Reset pulses longer than the minimum pulse width will generate a reset during active or sleep modes. Shorter pulses are not guaranteed to generate a reset. The JN5169 is held in reset while the RESET_N pin is low. When the applied signal reaches the reset threshold voltage (V_{rst}) on its positive edge, the internal reset process starts.

The JN5169 has an internal 500 kΩ pull-up resistor connect to the RESET_N pin. The pin is an input for an external reset only. By holding the RESET_N pin low, the JN5169 is held in reset, resulting in a typical current of 6 μA.

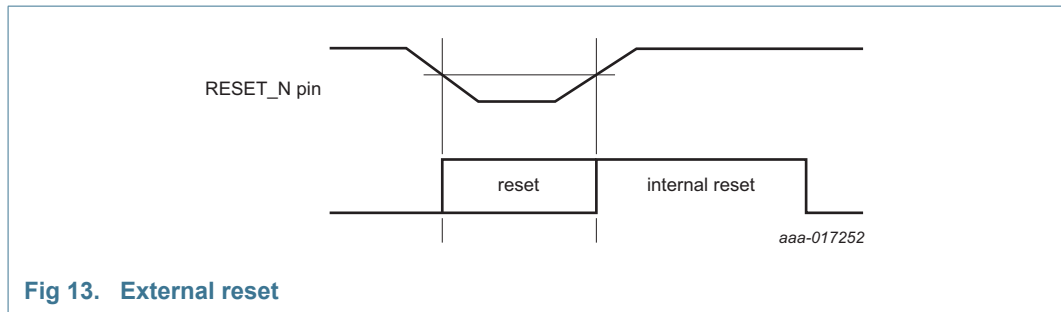

Fig 13. External reset

9.4.3 Software reset

A system reset can be triggered at any time through software control, causing a full chip reset and invalidating the RAM contents. For example, this can be executed within a user’s application upon detection of a system failure.

9.4.4 Supply Voltage Monitor (SVM)

An internal SVM is used to monitor the supply voltage to the JN5169; this can be used while the device is awake or is in CPU doze mode. Dips in the supply voltage below a variable threshold can be detected and can be used to cause the JN5169 to perform a chip reset. Equally, dips in the supply voltage can be detected and used to cause an interrupt to the processor, when the voltage either drops below the threshold or rises above it.

The SVM is enabled by default from power-up and can extend the reset during power-up. This will keep the CPU in reset until the voltage exceeds the SVM threshold voltage. The threshold voltage is configurable to 1.95 V, 2.0 V, 2.1 V, 2.2 V, 2.3 V, 2.4 V, 2.7 V or 3.0 V and is controllable by software. From power-up, the threshold is set according to the value stored in Flash and the default chip configuration is for the 2.0 V threshold. It is expected that the threshold is set to the minimum needed by the system. See [Figure 42](#) for more details on BOR and SVM characteristics.

9.4.5 Watchdog timer

A watchdog timer is provided to guard against software lock-ups. It operates by counting cycles of the high-speed RC system clock. A pre-scaler is provided to allow the expiry period to be set between typically 8 ms and 16.4 s (dependent on high-speed RC accuracy: +30 %, -15 %). Failure to restart the watchdog timer within the pre-configured timer period will cause a chip reset to be performed. A status bit is set if the watchdog was triggered so that the software can differentiate watchdog initiated resets from other resets, and can perform any required recovery once it restarts. Optionally, the watchdog can cause an exception rather than a reset; this preserves the state of the memory and is useful for debugging.

After power-up, reset, start from deep sleep or start from sleep, the watchdog is always enabled with the largest time-out period and will commence counting as if it had just been restarted. Under software control, the watchdog can be disabled. If it is enabled, the user must regularly restart the watchdog timer to stop it from expiring and causing a reset. The watchdog runs continuously, even during doze. However the watchdog does not operate during sleep or deep sleep, or when the hardware debugger has taken control of the CPU. If enabled, it will restart automatically once the debugger has uninstalled the CPU.

9.5 Interrupt system

A hardware-vectorized interrupt system is provided on the JN5169. The JN5169 provides several interrupt sources, some associated with CPU operations (CPU exceptions) and others which are used by hardware in the device. When an interrupt occurs, the CPU stops executing the current program and loads its program counter with a fixed hardware address specific to that interrupt. The interrupt handler or interrupt service routine is stored at this location and is run on the next CPU cycle. Execution of interrupt service routines is always performed in supervisor mode. Interrupt sources and their vector locations are shown in [Table 3](#).

Table 3. Interrupt vectors

Interrupt source	Vector location	Interrupt definition
Bus error	0x08	typically caused by an attempt to access an invalid address or a disabled peripheral
Tick timer	0x0E	tick timer interrupt asserted
Alignment error	0x14	load/store address to non-naturally aligned location
Illegal instruction	0x1A	attempt to execute an unrecognized instruction
Hardware interrupt	0x20	interrupt asserted
System call	0x26	system call initiated by b.sys instruction
Trap	0x2C	caused by the b.trap instruction or the debug unit
Reset	0x38	caused by software or hardware reset
Stack overflow	0x3E	stack overflow

9.5.1 System calls

The b.trap and b.sys instructions allow processor exceptions to be generated by software.

A system call exception will be generated when the b.sys instruction is executed. This exception can, for example, be used to enable a task to switch the processor into supervisor mode when a real-time operating system is in use (see [Section 9.5.3](#) for further details).

The b.trap instruction is commonly used for trapping errors and for debugging.

9.5.2 Processor exceptions

9.5.2.1 Bus error

A bus error exception is generated when software attempts to access a memory address that does not exist, or is not populated with memory or peripheral registers.

9.5.2.2 Alignment

Alignment exceptions are generated when software attempts to access objects that are not aligned to natural word boundaries. 16-bit objects must be stored on even byte boundaries, while 32-bit objects must be stored on quad byte boundaries. For instance, attempting to read a 16-bit object from address 0xFFF1 will trigger an alignment exception as will a read of a 32-bit object from 0xFFF1, 0xFFF2 or 0xFFF3. Examples of legal 32-bit object addresses are 0xFFF0, 0xFFF4, 0xFFF8 etc.

9.5.2.3 Illegal instruction

If the CPU reads an unrecognized instruction from memory as part of its instruction fetch, it will cause an illegal instruction exception.

9.5.2.4 Stack overflow

When enabled, a stack overflow exception occurs if the stack pointer reaches a programmable location.

9.5.3 Hardware interrupts

Hardware interrupts generated from the transceiver, analog or digital peripherals and DIO pins are individually masked using the Programmable Interrupt Controller (PIC). Management of interrupts is provided in the *JN516x Integrated Peripherals API User Guide (JN-UG-3087)* on the Wireless Connectivity area of the NXP web site [Ref. 1](#). For details of the interrupts generated from each peripheral, see the respective section in this data sheet.

Interrupts can be used to wake the JN5169 from sleep. The peripherals, baseband controller, security coprocessor and PIC are powered down during sleep but the DIO interrupts and optionally the pulse counters, wake-up timers and analog comparator interrupts remain powered to bring the JN5169 out of sleep.

Prioritized external interrupt handling (i.e., interrupts from hardware peripherals) is provided to enable an application to control an events priority to provide for deterministic program execution.

The priority Interrupt controller provides 15 levels of prioritized interrupts. The priority level of all interrupts can be set, with value 0 being used to indicate that the source can never produce an external interrupt, 1 for the lowest priority source(s) and 15 for the highest priority source(s). Note that multiple interrupt sources can be assigned the same priority level if desired.

If while processing an interrupt, a new event occurs at the same or lower priority level, a new external interrupt will not be triggered. However, if a new higher priority event occurs, the external interrupt will again be asserted, interrupting the current interrupt service routine.

Once the interrupt service routine is complete, lower priority events can be serviced.

9.6 Wireless transceiver

The wireless transceiver comprises a 2.4 GHz radio, modem, a baseband processor, a security coprocessor and PHY controller. These blocks, with protocol software provided as a library, implement an IEEE802.15.4 standards-based wireless transceiver that transmits and receives data over the air in the unlicensed 2.4 GHz band.

9.6.1 Radio

Figure 14 shows the single ended radio architecture.

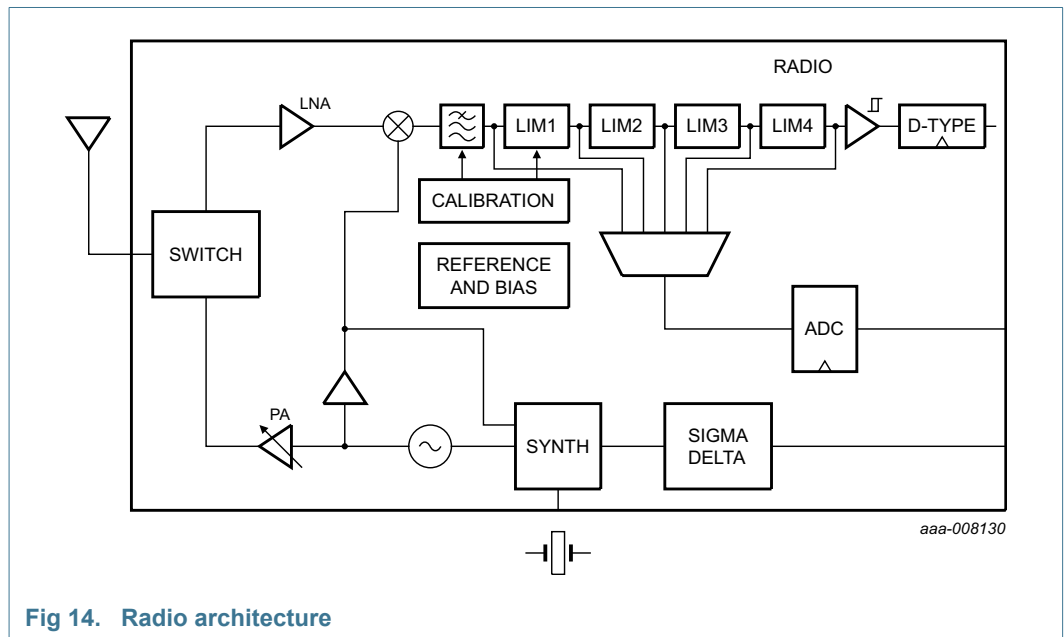

Fig 14. Radio architecture

The radio comprises a low-IF receive path and a direct modulation transmit path, which converge at the TX/RX switch. The switch connects to the external single-ended matching network, which consists of two inductors and a capacitor. This arrangement creates a 50 Ω port and removes the need for a balun. A 50 Ω single-ended antenna can be connected directly to this port.

The 32 MHz crystal oscillator feeds a divider, which provides the frequency synthesizer with a reference frequency. The synthesizer contains programmable feedback dividers, phase detector, charge pump and internal Voltage Controlled Oscillator (VCO). The VCO has no external components, and includes calibration circuitry to compensate for

differences in internal component values due to process and temperature variations. The VCO is controlled by a Phase-Locked Loop (PLL) that has an internal loop filter. A programmable charge pump is also used to tune the loop characteristic.

The receiver chain starts with the low noise amplifier/mixer combination whose outputs are passed to a low pass filter, which provides the channel definition. The signal is then passed to a series of amplifier blocks forming a limiting strip. The signal is converted to a digital signal before being passed to the Modem. The gain control for the RX path is derived in the Automatic Gain Control (AGC) block within the Modem, which samples the signal level at various points down the RX chain. To improve the performance and reduce current consumption, automatic calibration is applied to various blocks in the RX path.

In the transmit direction, the digital stream from the Modem is passed to a digital sigma-delta modulator which controls the feedback dividers in the synthesizer (dual point modulation). The VCO frequency now tracks the applied modulation. The 2.4 GHz signal from the VCO is then passed to the RF Power Amplifier (PA), whose power control can be selected from one of six settings. The output of the PA drives the antenna via the RX/TX switch

When enabled, the JN5169 radio is automatically calibrated for optimum performance. In operating environments with a significant variation in temperature (e.g. greater than 20 °C) due to diurnal or ambient temperature variation, it is recommended to recalibrate the radio to maintain performance. Recalibration is only required on Routers and End Devices that never sleep. End Devices that sleep when idle are automatically recalibrated when they wake. An Application Note *JN516x Temperature-Dependent Operating Guidelines (JN-AN-1186)* (on the Wireless Connectivity area of the NXP web site [Ref. 1](#)) describes this in detail and includes a software API function which can be used to test the temperature using the on-chip temperature sensor and trigger a recalibration if there has been a significant temperature change since the previous calibration.

9.6.1.1 Radio external components

In order to realize the full performance of the radio, it is essential that the reference PCB layout and BOM are carefully followed (see [Section 15](#)).

The radio is powered from a number of internal 1.8 V and 2.8 V regulators fed from the analog supply V_{DDA} , in order to provide good noise isolation between the digital logic of the JN5169 and the analog blocks. These regulators are also controlled by the baseband controller and protocol software to minimize power consumption. Decoupling for internal regulators is required as described in [Section 8.2.1](#).

For single-ended antennas or connectors, a balun is not required. However a matching network is needed.

The RF matching network requires three external components and the IBIAS pin requires one external component as shown in [Figure 15](#). These components are critical and should be placed close to the JN5169 pins and analog ground as defined in [Table 37](#). Specifically, the output of the network comprising L2, C1, L1 and C4 is designed to present an accurate match to a 50 Ω resistive network as well as provide a DC path to the final output stage or antenna. Users wishing to match to other active devices such as amplifiers should design their networks to match to 50 Ω at the output of L1.

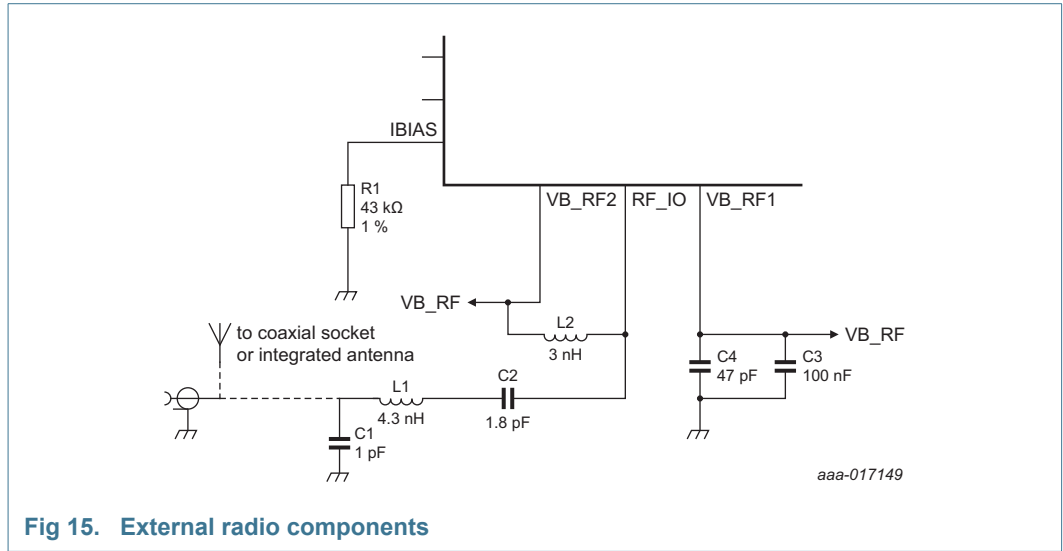

Fig 15. External radio components

9.6.1.2 Antenna diversity

Support is provided for antenna diversity, which is a technique that maximizes the performance of an antenna system. It allows the radio to switch between two antennas that have very low correlation between their received signals. Typically, this is achieved by spacing two antennae around 0.25 wavelengths apart or by using 2 orthogonal polarizations. So, if a packet is transmitted and no acknowledgement is received, the radio system can switch to the other antenna for the retry, with a different probability of success.

Additionally antenna diversity can be enabled while in receive mode waiting for a packet. The JN5169 measures the received energy in the relevant radio channel every 40 μs and the measured energy level is compared with a pre-set energy threshold, which can be set by the application program. The JN5169 device will automatically switch the antenna if the measurement is below this threshold, except if waiting for an acknowledgement from a previous transmission or if in the process of receiving a packet, when it will wait until this has finished. Also, it will not switch if a preamble symbol having a signal quality above a minimum specified threshold has not been detected in the last 40 μs.

Both modes can be used at once and use the same ADO (SELA) and ADE (SELB) outputs to control the external switch.

The JN5169 can provide an output (ADO) on DIO12 or DIO0 that is asserted on odd-numbered retries. Further, the complement of this output (ADE) can be made available on DIO13 or DIO1. Either or both of these signals can be used to control an antenna switch to support antenna diversity (see [Figure 16](#) and [Figure 17](#)).

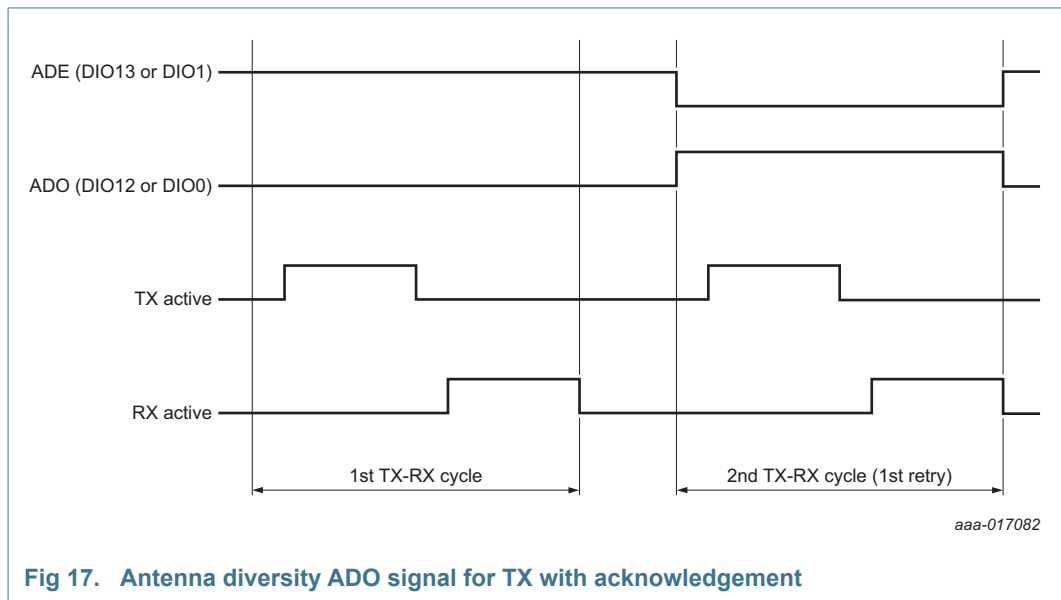
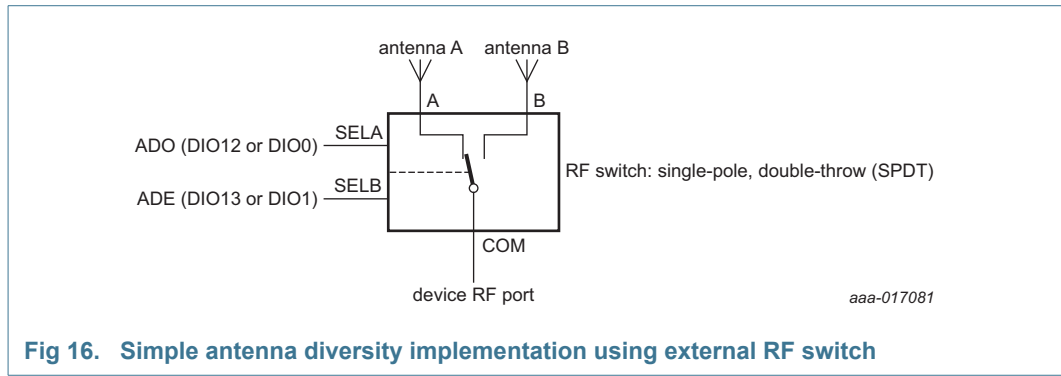

If only one DIO pin can be used, then either ADE or ADO can be connected to the first switch control pin and the same signal inverted on the second pin with an inverter on the PCB.

9.6.2 Modem

The modem performs all the necessary modulation and spreading functions required for digital transmission and reception of data at 250 kbits/s in the 2.4 GHz radio frequency band in compliance with the IEEE802.15.4 standard.

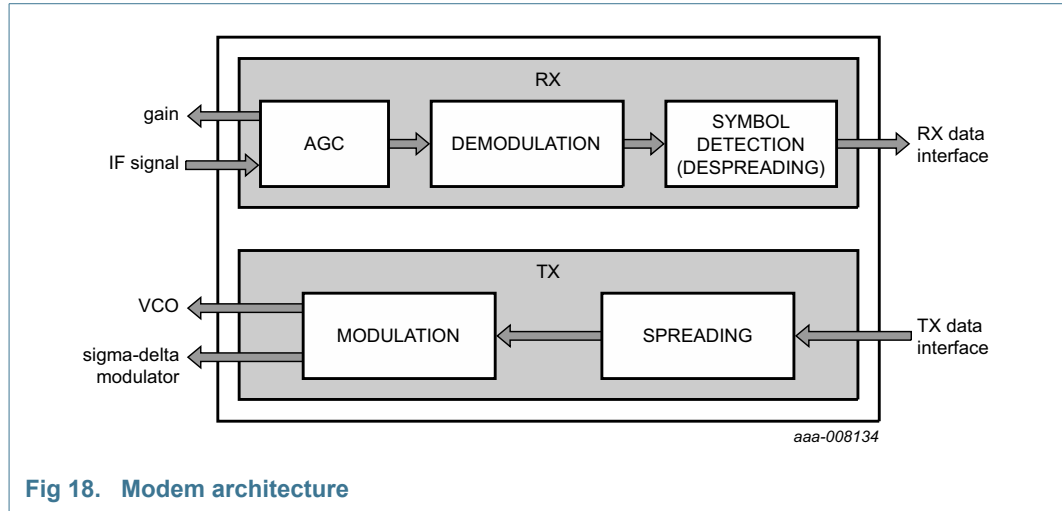

Fig 18. Modem architecture

Features provided to support network channel selection algorithms include Energy Detection (ED), Link Quality Indication (LQI) and fully programmable Clear Channel Assessment (CCA).

The modem provides a digital Receive Signal Strength Indication (RSSI) that facilitates the implementation of the IEEE802.15.4 ED function and LQI function.

The ED and LQI are both related to receiver power in the same way, as shown in Figure 19. LQI is associated with a received packet, whereas ED is an indication of signal power-on air at a particular moment.

The CCA capability of the modem supports all modes of operation defined in the IEEE802.15.4 standard, namely Energy above ED threshold, Carrier Sense and Carrier Sense and/or energy above ED threshold.

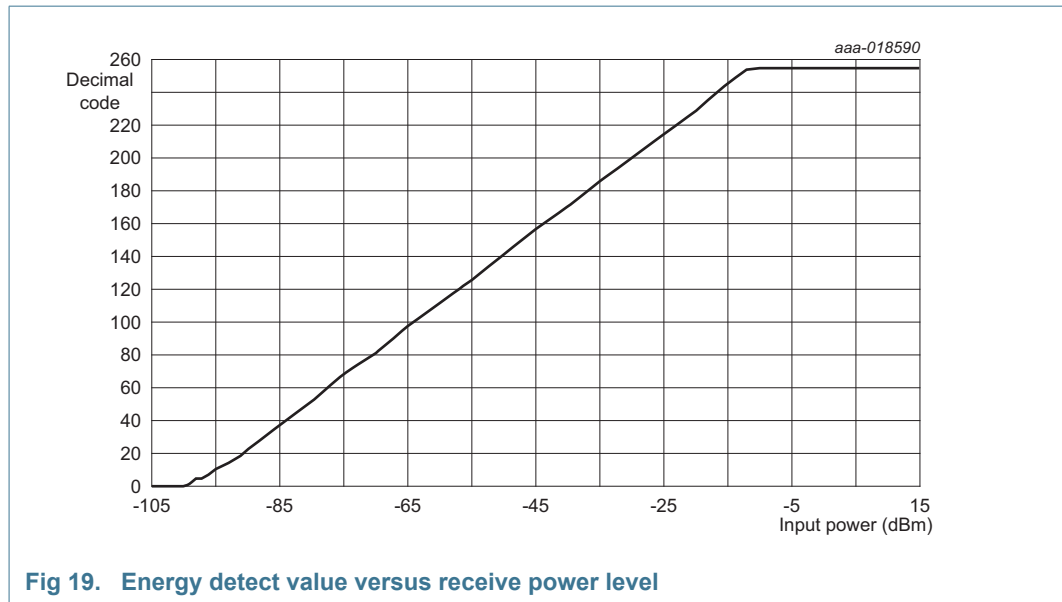

Fig 19. Energy detect value versus receive power level

9.6.3 Baseband processor

The baseband processor provides all time-critical functions of the IEEE802.15.4 MAC layer. Dedicated hardware guarantees air interface timing is precise. The MAC layer hardware/software partitioning enables software to implement the sequencing of events required by the protocol and to schedule timed events with millisecond resolution, and the hardware to implement specific events with microsecond timing resolution. The protocol software layer performs the higher-layer aspects of the protocol, sending management and data messages between End Device and Co-ordinator nodes, using the services provided by the baseband processor.

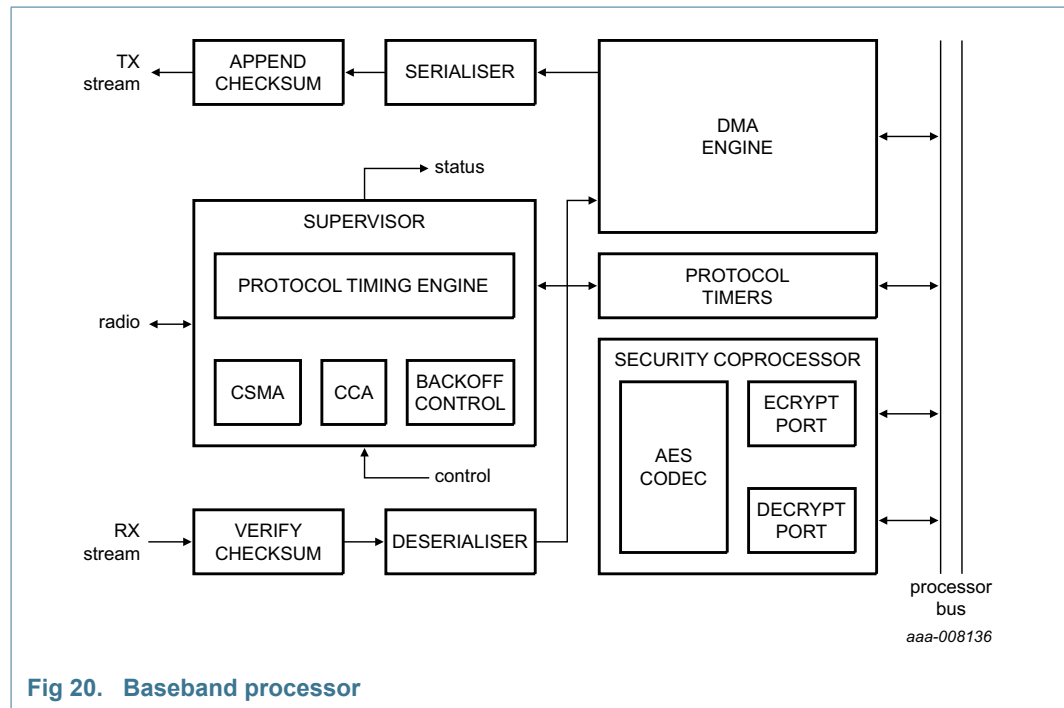

Fig 20. Baseband processor

9.6.3.1 Transmit

A transmission is performed by software writing the data to be transferred into the TX frame buffer in RAM, together with parameters such as the destination address and the number of retries allowed, as well as programming one of the protocol timers to indicate the time at which the frame is to be sent. This time will be determined by the software tracking the higher-layer aspects of the protocol such as superframe timing and slot boundaries. Once the packet is prepared and protocol timer set, the supervisor block controls the transmission. When the scheduled time arrives, the supervisor controls the sequencing of the radio and modem to perform the type of transmission required, fetching the packet data directly from RAM. It can perform all the algorithms required by IEEE802.15.4 such as CSMA/CA without processor intervention including retries and random back-offs.

When the transmission begins, the header of the frame is constructed from the parameters programmed by the software and sent with the frame data through the serializer to the modem. At the same time, the radio is prepared for transmission. During the passage of the bitstream to the modem, it passes through a CRC checksum generator that calculates the checksum on-the-fly, and appends it to the end of the frame.

9.6.3.2 Reception

During reception, the radio is set to receive on a particular channel. On receipt of data from the modem, the frame is directed into the RX frame buffer in RAM where both header and frame data can be read by the protocol software. An interrupt may be provided on receipt of the frame. An additional interrupt may be provided after the transmission of an acknowledgement frame in response to the received frame, if an acknowledgement frame has been requested and the auto acknowledge mechanism is enabled, see [Section 9.6.3.3](#). As the frame data is being received from the modem, it is passed through a checksum generator; at the end of the reception the checksum result is compared with the checksum at the end of the message to ensure that the data has been received correctly. During reception, the modem determines the Link Quality, which is made available at the end of the reception as part of the requirements of IEEE802.15.4.

9.6.3.3 Auto acknowledge

Part of the protocol allows for transmitted frames to be acknowledged by the destination sending an acknowledge packet within a very short window after the transmitted frame has been received. The JN5169 baseband processor can automatically construct and send the acknowledgement packet without processor intervention and hence avoid the protocol software being involved in time-critical processing within the acknowledge sequence. The JN5169 baseband processor can also request an acknowledge for packets being transmitted and handle the reception of acknowledged packets without processor intervention.

9.6.3.4 Security

The transmission and reception of secured frames using the Advanced Encryption Standard (AES) algorithm is handled by the security coprocessor and the stack software. The application software must provide the appropriate encrypt/decrypt keys for the transmission or reception. On transmission, the key can be programmed at the same time as the rest of the frame data and set-up information.

9.6.4 Security coprocessor

The security coprocessor is available to the application software to perform encryption/decryption operations. A hardware implementation of the encryption engine significantly speeds up the processing of the encrypted packets over a pure software implementation. The AES library for the JN5169 provides operations that utilize the encryption engine in the device and allow the contents of memory buffers to be transformed. Information such as the type of security operation to be performed and the encrypt/decrypt key to be used must also be provided.

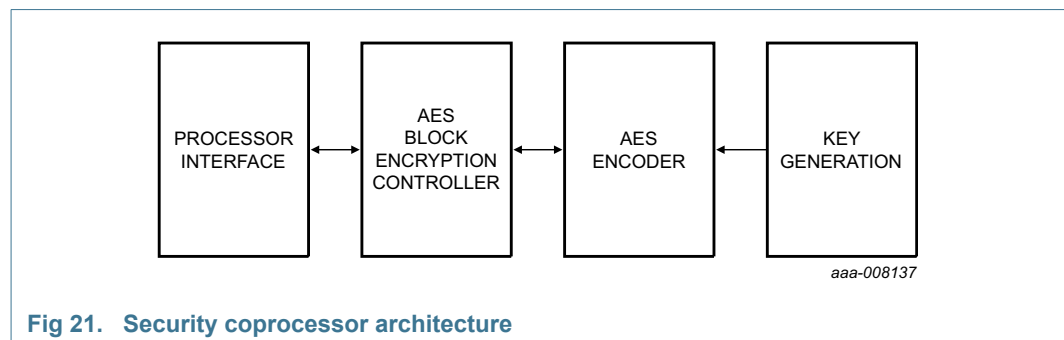

Fig 21. Security coprocessor architecture

9.7 Digital Input/Output

There are 20 Digital I/O (DIO) pins which, when used as general-purpose pins, can be configured as either an input or an output, with each having a selectable internal pull-up resistor. In addition, there are 2 Digital Output (DO) pins.

Most DIO pins are shared with the digital and analog peripherals of the device. When a peripheral is enabled, it takes control over the device pins allocated to it. However, note that most peripherals have two alternative pin allocations to alleviate clashes between uses, and many peripherals can disable the use of specific pins if not required. See [Section 8.2](#) and the individual peripheral descriptions for full details of the available pinout arrangements.

Following a reset (and while the RESET_N input is held low), all peripherals are forced off and the DIO pins are configured as inputs with the internal pull-ups turned on. When a peripheral is not enabled, the DIO pins associated with it can be used as digital inputs or outputs. Each pin can be controlled individually by setting the direction and then reading or writing to the pin.

The individual pull-up resistors, R_{PU} , can also be enabled or disabled as needed and the setting is held through sleep cycles. The pull-ups are generally configured once after reset depending on the external components and functionality. For instance, outputs should generally have the pull-ups disabled. An input that is always driven should also have the pull-up disabled.

When configured as an input, each pin can be used to generate an interrupt upon a change of state (selectable transition either from low to high or high to low); the interrupt can be enabled or disabled. When the device is sleeping, these interrupts become events that can be used to wake up the device. Equally the status of the interrupt may be read. See [Section 10](#) for further details on sleep and wake-up.

The state of all DIO pins can be read, irrespective of whether the DIO is configured as an input or an output.

Throughout a sleep cycle, the direction of the DIOs and the state of the outputs are held. This is based on the resultant of the GPIO Data/Direction registers and the effect of any enabled peripherals at the point of entering sleep. Following a wake-up these directions and output values are maintained under control of the GPIO data/direction registers. Any peripherals enabled before the sleep cycle are not automatically re-enabled; this must be done through software after the wake-up.

For example, if DIO0 is configured to be SPISEL1 then it becomes an output. The output value is controlled by the SPI-bus functional block. If the device then enters a sleep cycle, the DIO will remain an output and hold the value being output when entering sleep. After wake-up, the DIO will still be an output with the same value but controlled from the GPIO Data/Direction registers. It can be altered with the software functions that adjust the DIO, or the application may reconfigure it to be SPISEL1.

Unused DIO pins are recommended to be set as inputs with the pull-up enabled.

Two DIO pins can optionally be used to provide control signals for RF circuitry (e.g. switches and PA) in high-power range extenders.

DIO3/RFTX is asserted when the radio is in the transmit state and similarly, DIO2/RFRX is asserted when the radio is in the receiver state.

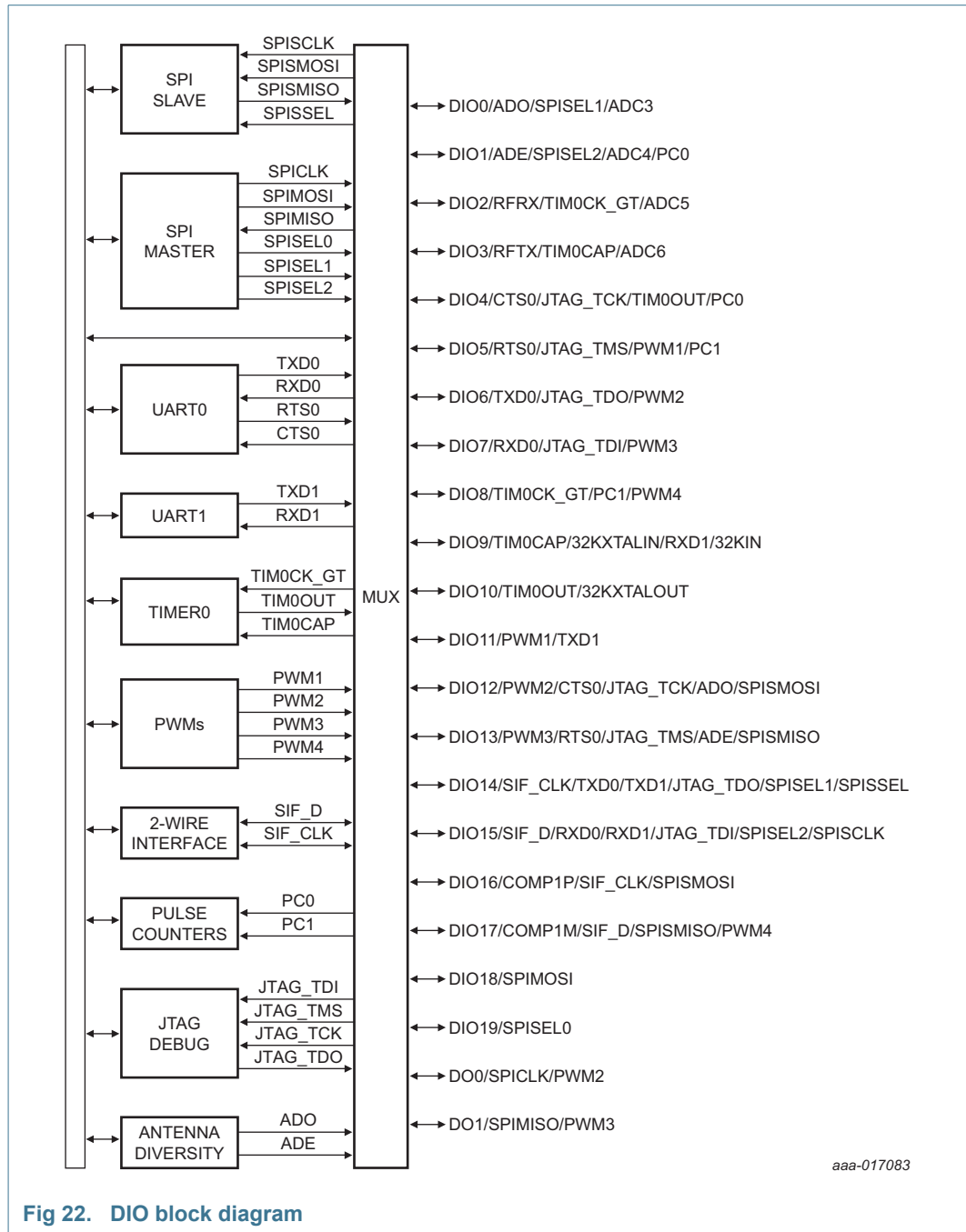

Fig 22. DIO block diagram

9.8 Serial Peripheral Interface-bus

9.8.1 SPI-bus master

The SPI-bus allows high-speed synchronous data transfer between the JN5169 and peripheral devices. The JN5169 operates as a master on the SPI-bus and all other devices connected to the SPI-bus are expected to be slave devices under the control of the JN5169 CPU. The SPI-bus includes the following features:

- Full-duplex, 3-wire synchronous data transfer

- Programmable bit rates (up to 16 Mbit/s)
- Programmable transaction size up to 32 bits
- Standard SPI-bus modes 0, 1, 2 and 3
- Manual or automatic slave select generation (up to 3 slaves)
- Maskable transaction complete interrupt
- LSB first or MSB first data transfer
- Supports delayed read edges

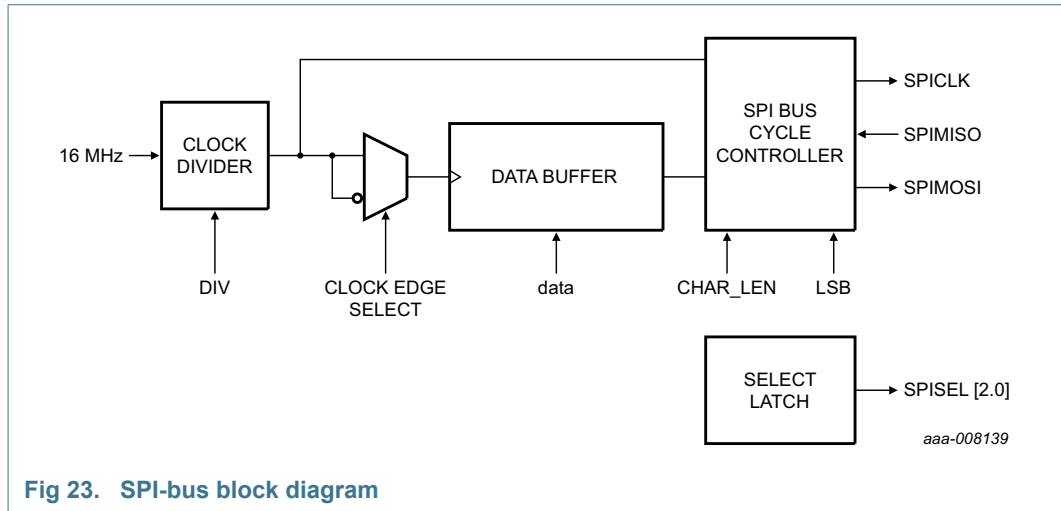

Fig 23. SPI-bus block diagram

The SPI-bus employs a simple shift register data transfer scheme. Data is clocked out of and into the active devices in a first-in, first-out fashion allowing SPI-bus devices to transmit and receive data simultaneously. Master-Out-Slave-In or Master-In-Slave-Out data transfer is relative to the clock signal SPICLK generated by the JN5169.

The JN5169 provides 3-slave selects, SPISEL0 to SPISEL2 to allow three SPI-bus peripherals on the bus. SPISEL0 is accessed on DIO19. SPISEL1 is accessed, depending upon the configuration, on DIO0 or DIO14. SPISEL2 is accessed on DIO1 or DIO15. This is enabled under software control. The following table details which DIOs are used for the SPISEL signals depending upon the configuration.

Table 4. SPI-bus master I/O

Signal	DIO assignment	
	Standard pins	Alternative pins
SPISEL1	DIO0	DIO14
SPISEL2	DIO1	DIO15
SPICLK	DO0	
SPIMISO	DO1	
SPIMOSI	DIO18	
SPISEL0	DIO19	

The interface can transfer from 1-bit to 32-bit without software intervention and can keep the slave select lines asserted between transfers when required, to enable longer transfers to be performed.

When the device reset is active, all the SPI-bus master pins are configured as inputs with their pull-up resistors active. The pins stay in this state until the SPI-bus master block is enabled, or the pins are configured for some other use.

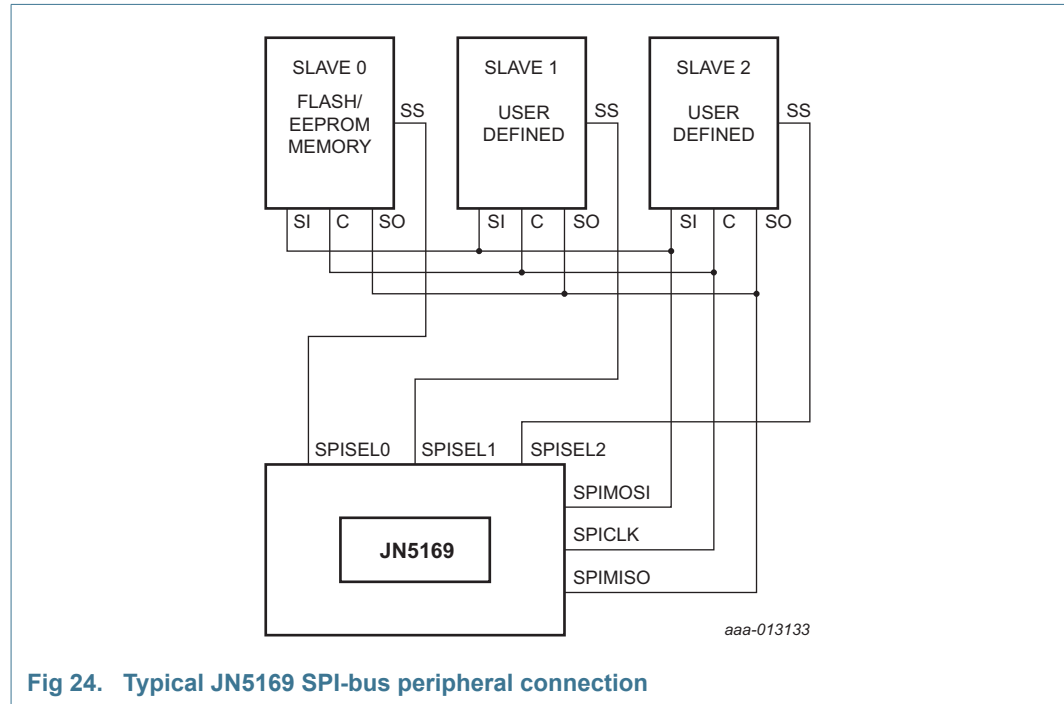

Fig 24. Typical JN5169 SPI-bus peripheral connection

The data transfer rate on the SPI-bus is determined by the SPICLK signal. The JN5169 supports transfers at selectable data rates from 16 MHz to 125 kHz selected by a clock divider. Both SPICLK clock phase and polarity are configurable. The clock phase determines which edge of SPICLK is used by the JN5169 to present new data on the SPIMOSI line; the opposite edge will be used to read data from the SPIMISO line. The interface should be configured appropriately for the SPI-bus slave being accessed.

Table 5. SPI-bus configurations

SPICLK		Mode	Description
Polarity	Phase		
0	0	0	SPICLK is low when idle - the first edge is positive. Valid data is output on SPIMOSI before the first clock and changes every negative edge. SPIMISO is sampled every positive edge.
0	1	1	SPICLK is low when idle – the first edge is positive. Valid data is output on SPIMOSI every positive edge. SPIMISO is sampled every negative edge.
1	0	2	SPICLK is high when idle – the first edge is negative. Valid data is output on SPIMOSI before the first clock edge and is changed every positive edge. SPIMISO is sampled every negative edge.
1	1	3	SPICLK is high when idle – the first edge is negative. Valid data is output on SPIMOSI every negative edge. SPIMISO is sampled every positive edge.

If more than one SPISEL line is to be used in a system, they must be used in numerical order starting from SPISEL0. A SPISEL line can be automatically de-asserted between transactions if required, or it may stay asserted over a number of transactions. For

devices such as memories where a large amount of data can be received by the master by continually providing SPICLK transitions, the ability for the select line to stay asserted is an advantage since it keeps the slave enabled over the whole of the transfer.

A transaction commences with the SPI-bus being set to the correct configuration, and then the slave device is selected. Upon commencement of transmission (1-bit to 32-bit) data is placed in the FIFO data buffer and clocked out, at the same time generating the corresponding SPICLK transitions. Since the transfer is full-duplex, the same number of data bits is being received from the slave as it transmits. The data that is received during this transmission can be read (1-bit to 32-bit). If the master simply needs to provide a number of SPICLK transitions to allow data to be sent from a slave, it should perform transmit using dummy data. An interrupt can be generated when the transaction has completed or alternatively the interface can be polled.

If a slave device wishes to signal the JN5169 indicating that it has data to provide, it may be connected to one of the DIO pins that can be enabled as an interrupt.

Figure 25 shows a complex SPI-bus transfer, reading data from a Flash device that can be achieved using the SPI-bus master interface. The slave select line must stay low for many separate SPI-bus accesses, and therefore manual slave select mode must be used. The required slave select can then be asserted (active low) at the start of the transfer. A sequence of 8-bit and 32-bit transfers can be used to issue the command and address to the Flash device and then to read data back. Finally, the slave select can be deselected to end the transaction.

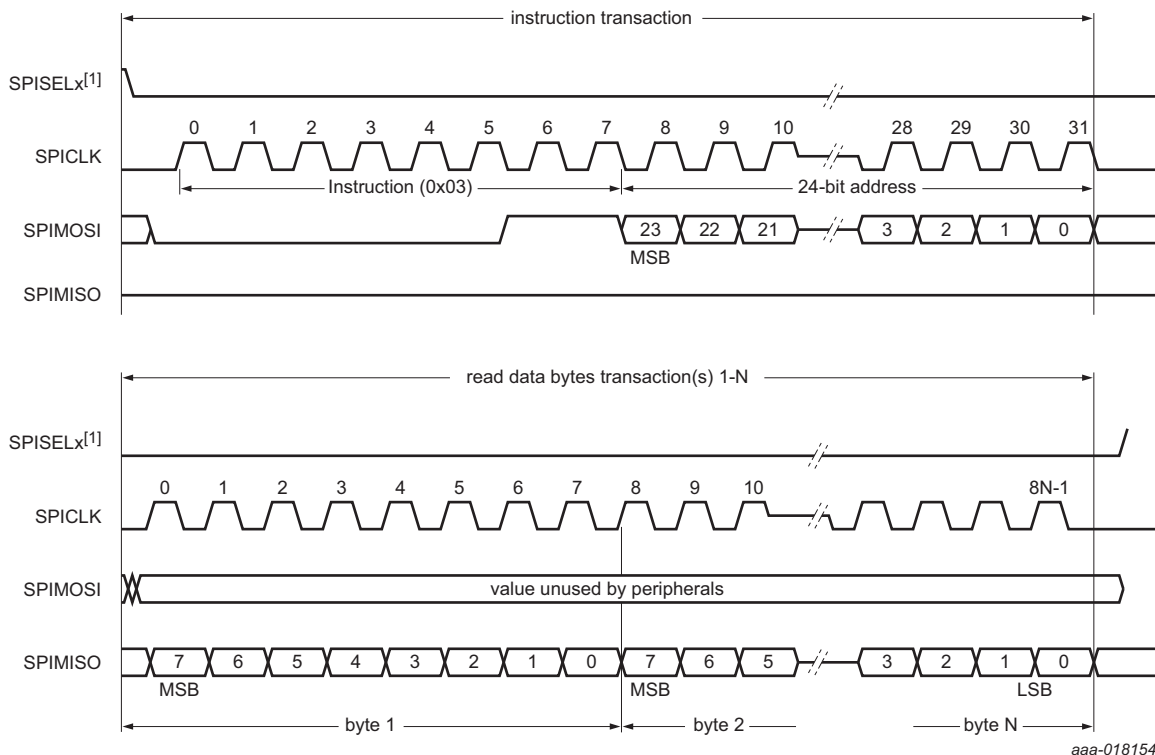

(1) With x = 0, 1 or 2.

Fig 25. Example SPI-bus waveforms: reading from Flash device using mode 0

9.8.2 SPI-bus slave

The SPI-bus slave interface allows high-speed synchronous data transfer between the JN5169 and a peripheral device. The JN5169 operates as a slave on the SPI-bus and an external device, connected to the SPI-bus operates as the master. The pins are different from the SPI-bus master interface and are shown in the [Table 6](#).

Table 6. SPI-bus slave I/O

Signal	DIO assignment	
	Standard pins	Alternative pins
SPISCLK	DIO15	-
SPISMISO	DIO13	DIO17
SPISMOSI	DIO12	DIO16
SPISSEL	DIO14	-

The SPI-bus employs a simple shift register data transfer scheme, with SPISSEL acting as the active-low select control. Data is clocked out of and into the active devices in a first-in, first-out fashion allowing SPI-bus devices to transmit and receive data simultaneously. Master-Out-Slave-In or Master-In-Slave-Out data transfer is relative to the clock signal SPISCLK generated by the external master.

The SPI-bus slave includes the following features:

- Full-duplex synchronous data transfer
- Slaves to external clock up to 8 MHz
- Supports 8-bit transfers (MSB or LSB first configurable), with SPISSEL deasserted between each transfer
- Internal FIFO up to 255 bytes for transmit and receive
- Standard SPI-bus mode 0; data is sampled on positive clock edge
- Maskable interrupts for receive FIFO not empty, transmit FIFO empty, receive FIFO fill level above threshold, transmit FIFO below threshold, transmit FIFO overflow, receive FIFO underflow, transmit FIFO underflow, receive time-out
- Programmable receive time-out period allows an interrupt to be generated to prompt the receive FIFO to be read if no further data arrives within the time-out period

9.9 Timers

9.9.1 Peripheral timer/counters

A general-purpose timer/counter unit, Timer0, is available that can be configured to operate in one of four possible modes:

1. Timer: can generate interrupts OFF rise and fall counts. Can be gated by external signal
2. Counter: counts number of transitions on external event signal. Can use low-high, high-low or both transitions PWM/Single pulse: outputs repeating Pulse Width Modulation signal or a single pulse. Can set period and mark-space ratio
3. Capture: measures times between transitions of an applied signal
4. Delta-Sigma: Return-To-Zero (RTZ) and Non-Return-to-Zero (NRZ) modes

The Timer functionality is as follows:

- Clocked from internal system clock (16 MHz)
- 5-bit prescaler, divides system clock by 2^{prescale} as the clock to the timer (prescaler range is 0 to 16)
- 16-bit counter, 16-bit Rise and Fall (period) registers
- Timer: can generate interrupts off Rise and Fall counts. Can be gated by external signal
- Counter: counts number of transitions on external event signal. Can use low-high, high-low or both transitions
- PWM/Single pulse: outputs repeating Pulse Width Modulation signal or a single pulse. Can set period and mark-space ratio
- Capture: measures times between transitions of an applied signal
- Delta-Sigma: Return-To-Zero (RTZ) and Non-Return-to-Zero (NRZ) modes
- Timer usage of external IO can be controlled on a pin by pin basis

Four further timers are also available that support the same functionality but have no counter or capture mode. These are referred to as PWM timers. Additionally, it is not possible to gate these four timers with an external signal.

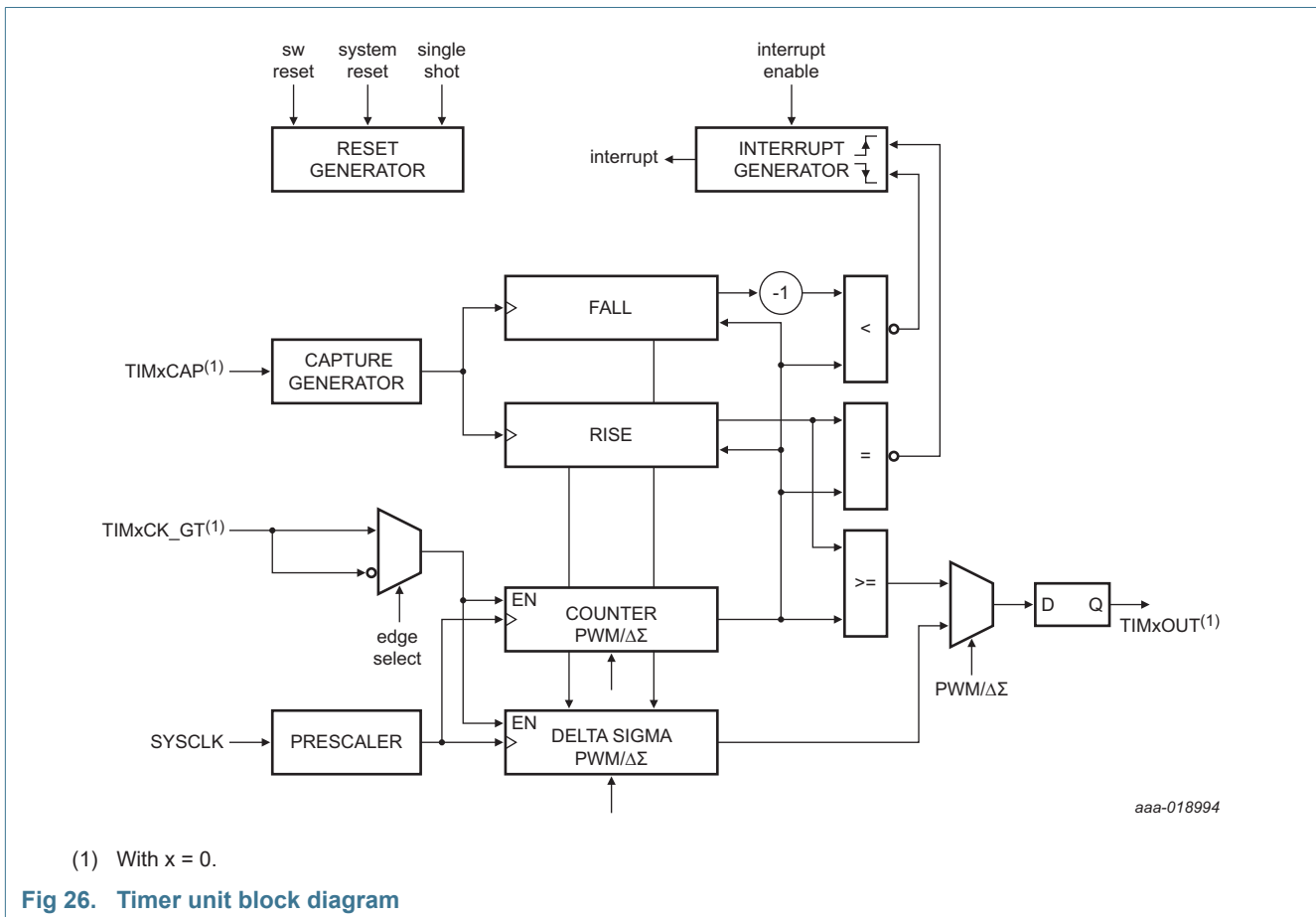

Fig 26. Timer unit block diagram

The clock source for the Timer0 unit is fed from the 16 MHz system clock. This clock passes to a 5-bit prescaler where a value of 0 leaves the clock unmodified and other values divide it by 2^{prescale} . For example, a prescale value of 2 applied to the 16 MHz system clock source results in a timer clock of 4 MHz.

The counter is optionally gated by a signal on the clock/gate input (TIM0CK_GT). If the gate function is selected, then the counter is frozen when the clock/gate input is high.

An interrupt can be generated whenever the counter is equal to the value in either of the High or Low registers.

[Table 7](#) details which DIOs are used for Timer0 and the PWM timers depending upon the configuration.

Table 7. Timer and PWM I/O

Signal	DIO assignment	
	Standard pins	Alternative pins
TIM0CK_GT	DIO8	DIO2
TIM0CAP	DIO9	DIO3
TIM0OUT	DIO10	DIO4
PWM1	DIO11	DIO5
PWM2	DIO12	DIO6
PWM3	DIO13	DIO7
PWM4	DIO17	DIO8

If operating in timer mode, it is not necessary to use any of the DIO pins, allowing the standard DIO functionality to be available to the application.

9.9.2 Pulse Width Modulation mode

Pulse Width Modulation (PWM) mode, as used by PWM timers 1, 2, 3 and 4 and optionally by Timer0, allows the user to specify an overall cycle time and pulse length within the cycle. The pulse can be generated either as a single shot or as a train of pulses with a repetition rate determined by the cycle time.

In this mode, the cycle time and low periods of the PWM output signal can be set by the values of two independent 16-bit registers (fall and rise). The counter increments and its output is compared to the 16-bit Rise and Fall registers. When the counter is equal to the Rise register, the PWM output is set to high; when the counter reaches the Fall value, the output returns to low. In continuous mode, when the counter reaches the Fall value, it will reset and the cycle repeats. If either the cycle time or low periods are changed while in continuous mode, the new values are not used until a full cycle has completed. The PWM waveform is available on PWM1, 2, 3, 4 or TIM0OUT when the output driver is enabled.

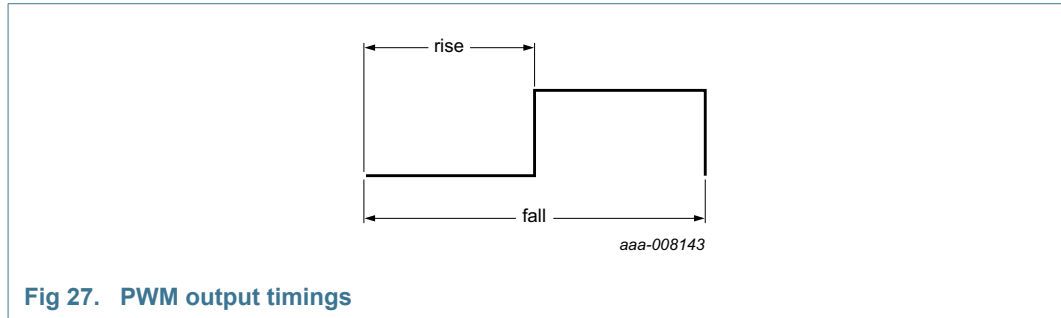

Fig 27. PWM output timings

9.9.3 Capture mode

The capture mode can be used to measure the time between transitions of a signal applied to the capture input (TIM0CAP). When the capture is started, on the next low-to-high transition of the captured signal, the count value is stored in the rise register, and on the following high-to-low transition, the counter value is stored in the fall register. The pulse width is the difference in counts in the two registers multiplied by the period of the prescaled clock. Upon reading the capture registers, the counter is stopped. The values in the high and low registers will be updated whenever there is a corresponding transition on the capture input, and the value stored will be relative to when the mode was started. Therefore, if multiple pulses are seen on TIM0CAP before the counter is stopped, only the last pulse width will be stored.

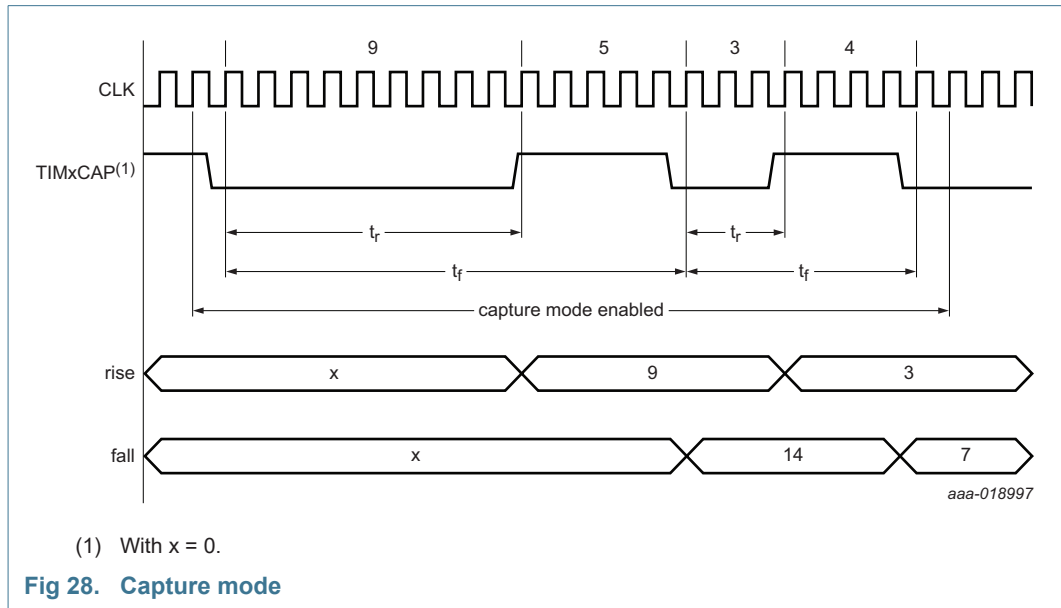

Fig 28. Capture mode

9.9.4 Counter/timer mode

The counter/timer can be used to generate interrupts, based on the timers or event counting, for software to use. As a timer, the clock source is from the system clock, prescaled if required. The timer period is programmed into the Fall register and the Fall register match interrupt enabled. The timer is started as either a single-shot or a repeating timer, and generates an interrupt when the counter reaches the Fall register value.

When used to count external events on TIM0CK_GT, the clock source is selected from the input pin and the number of events programmed into the Fall register. The Fall register match interrupt is enabled and the counter started, usually in single-shot mode. An interrupt is generated when the programmed number of transitions is seen on the input pin. The transitions counted can configure to be rising edges, falling edges or both rising and falling edges.

Edges on the event signal must be at least 100 ns apart; that is pulses must be wider than 100 ns.

9.9.5 Delta-sigma mode

A separate delta-sigma mode is available, allowing a low-speed delta-sigma DAC to be implemented with up to 16-bit resolution. This requires that a resistor-capacitor network is placed between the output DIO pin and digital ground. A stream of pulses with digital voltage levels is generated which is integrated by the RC network to give an analog voltage. A conversion time is defined in terms of a number of clock cycles. The width of the pulses generated is the period of a clock cycle. The number of pulses output in the cycle, together with the integrator RC values, will determine the resulting analog voltage. For example, generating approximately half the number of pulses that make up a complete conversion period will produce a voltage on the RC output of V_{DD} , provided the RC time constant is chosen correctly. During a conversion, the pulses will be pseudo-randomly dispersed throughout the cycle in order to produce a steady voltage on the output of the RC network.

The output signal is asserted for the number of clock periods defined in the high register, with the total period being 2^{16} cycles. For the same value in the high register, the pattern of pulses on subsequent cycles is different, due to the pseudo-random distribution.

The delta-sigma converter output can operate in a Return-To-Zero (RTZ) or Non-Return-to-Zero (NRZ) mode. The NRZ mode will allow several pulses to be output next to each other. The RTZ mode ensures that each pulse is separated from the next by at least one period. This improves linearity if the rise and fall times of the output are different to one another. Essentially, the output signal is low on every other output clock period, and the conversion cycle time is twice the NRZ cycle time; that is 2^{17} clocks. The integrated output will only reach half V_{DD} in RTZ mode, since even at full scale only half the cycle contains pulses. Figure 29 and Figure 30 illustrate the difference between RTZ and NRZ for the same programmed number of pulses.

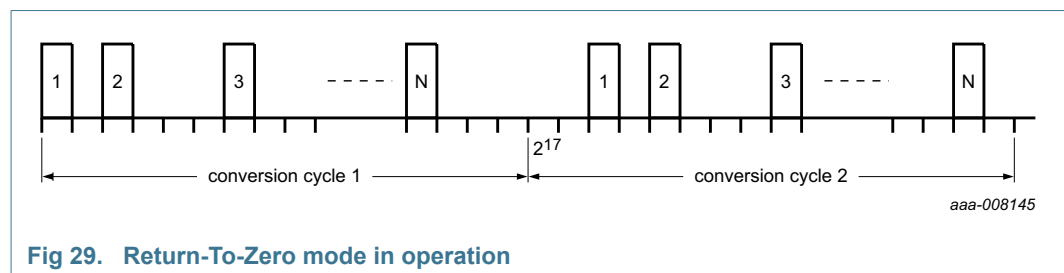

Fig 29. Return-To-Zero mode in operation

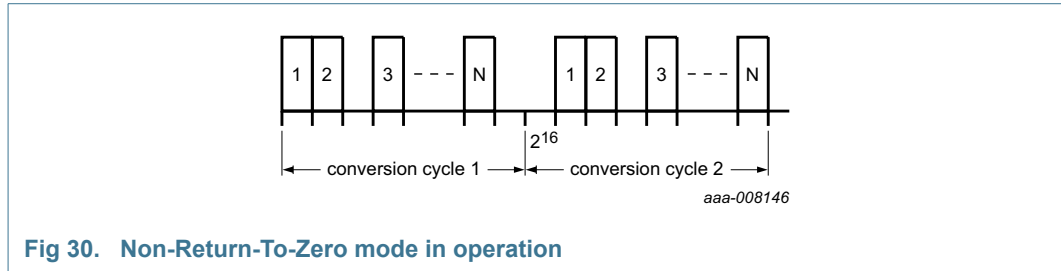

Fig 30. Non-Return-To-Zero mode in operation

9.9.6 Example timer/counter application

Figure 31 shows an application of the JN5169 timers to provide closed-loop speed control. Timer PWM1 is configured in PWM mode to provide a variable mark-space ratio switching waveform to the gate of the NFET. This in turn controls the power in the DC motor.

Timer 0 is configured to count the rising edge events on the CLK/GATE pin over a constant period. This converts the tacho pulse stream output into a count proportional to the motor speed. This value is then used by the application software executing the control algorithm.

If required for other functionality, the unused IO associated with the timers could be used as general-purpose DIO.

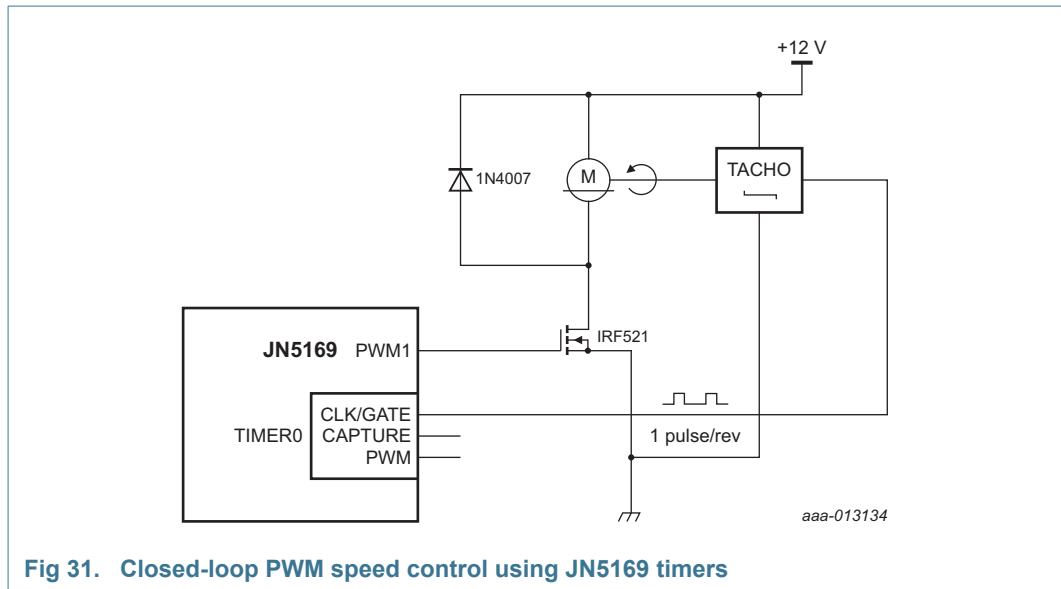

Fig 31. Closed-loop PWM speed control using JN5169 timers

9.9.7 Tick timer

The JN5169 contains a hardware timer that can be used for generating timing interrupts to software. It may be used to implement regular events such as ticks for software timers or an operating system, as a high-precision timing reference or can be used to implement system monitor time-outs as used in a watchdog timer. Features include:

- 32-bit counter
- 28-bit match value
- Maskable timer interrupt

- Single-shot, restartable and continuous modes of operation

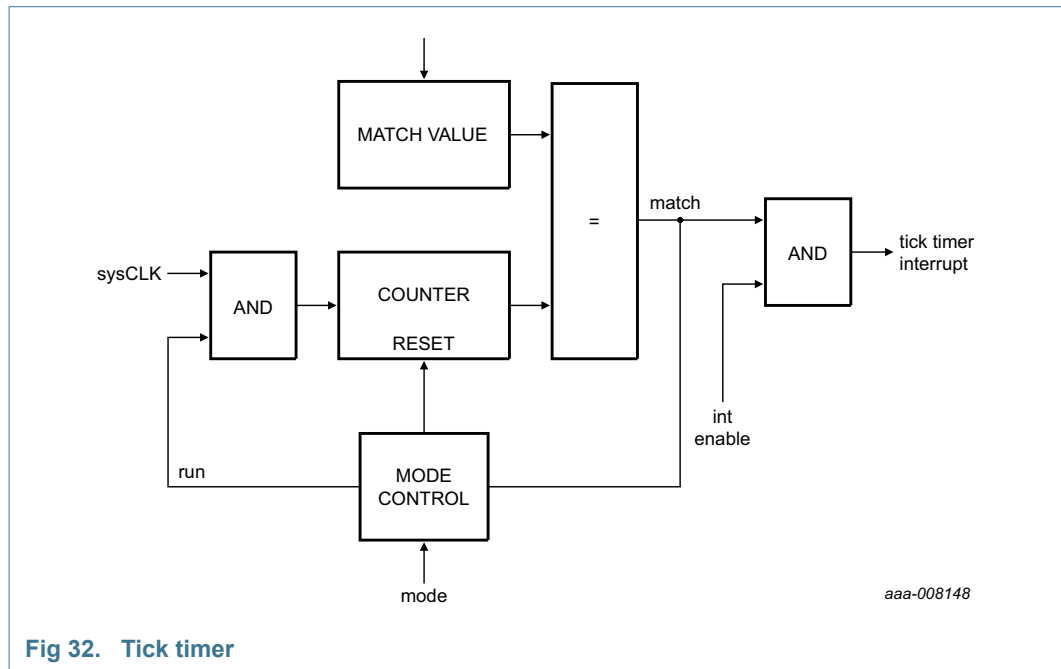

Fig 32. Tick timer

The tick timer is clocked from a continuous 16 MHz clock, which is fed to a 32-bit wide resettable up-counter, gated by a signal from the mode control block. A match register allows comparison between the counter and a programmed value. The match value, measured in 16 MHz clock cycles is programmed through software, in the range 0 to 0x0FFFFFFF. The output of the comparison can be used to generate an interrupt (if the interrupt is enabled) and used in controlling the counter in the different modes. Upon configuring the timer mode, the counter is also reset.

If the mode is programmed as single-shot, the counter begins to count from zero until the match value is reached. The match signal will be generated which will cause an interrupt (if enabled) and the counter will stop counting. The counter is restarted by reprogramming the mode.

If the mode is programmed as restartable mode, the operation of the counter is the same as for the single-shot mode, except that when the match value is reached the counter is reset and begins counting from zero. An interrupt will be generated when the match value is reached (if it is enabled).

Continuous mode operation is similar to restartable mode, except that when the match value is reached the counter is not reset but continues to count. An interrupt will be generated when the match value is reached (if enabled).

9.9.8 Wake-up timers

Two 41-bit wake-up timers are available on the JN5169, driven from the 32 kHz internal clock. They may run during sleep periods when the majority of the rest of the device is powered down, to time sleep periods or other long period timings that may be required by the application. The wake-up timers do not run during deep sleep and may optionally be disabled in sleep mode through software control. When a wake-up timer expires, it

typically generates an interrupt; if the device is asleep then the interrupt may be used as an event to end the sleep period. See [Section 10](#) for further details on how the wake-up timers are used during sleep periods. Features include:

- 41-bit down counter
- Optionally runs during sleep periods
- Clocked by 32 kHz system clock; either 32 kHz RC oscillator, 32 kHz XTAL oscillator or 32 kHz clock input

A wake-up timer consists of a 41-bit down counter clocked from the selected 32 kHz clock. An interrupt or wake-up event can be generated when the counter reaches zero. On reaching zero, the counter will continue to count down until stopped, which allows the latency in responding to the interrupt to be measured. If an interrupt or wake-up event is required, the timer interrupt should be enabled before loading the count value for the period. Once the counter value has been loaded and the counter started, the count-down begins. The counter can be stopped at any time through software control - the counter will remain at the value that it contained when it was stopped and no interrupt will be generated. The status of the timers can be read to indicate if the timers are running and/or have expired; this is useful when the timer interrupts are masked. This operation will reset any expired status flags.

9.9.9 32 kHz RC oscillator calibration

The 32 kHz RC oscillator that can be used to time sleep periods is designed to require very little power to operate and be self-contained, requiring no external timing components and hence is lower cost. As a consequence of using on-chip resistors and capacitors, the inherent absolute accuracy and temperature coefficient is lower than that of a crystal oscillator, but once calibrated the accuracy approaches that of a crystal oscillator. Sleep time periods should be as close to the desired time as possible in order to allow the device to wake up in time for important events - for example, beacon transmissions in the IEEE802.15.4 protocol. If the sleep time is accurate, the device can be programmed to wake up very close to the calculated time of the event and so keep current consumption to a minimum. If the sleep time is less accurate, it will be necessary to wake up earlier in order to be certain that the event will be captured. If the device wakes earlier, it will be awake for longer and so reduce battery life.

In order to allow sleep time periods to be as close to the desired length as possible, the true frequency of the RC oscillator needs to be determined to better than the initial 30 % accuracy. The calibration factor can then be used to calculate the true number of nominal 32 kHz periods needed to make up a particular sleep time. A calibration reference counter, clocked from the 16 MHz system clock, is provided to allow comparisons to be made between the 32 kHz RC clock and the 16 MHz system clock when the JN5169 is awake and running from the 32 MHz crystal.

Wake-up Timer0 counts for a set number of 32 kHz clock periods during which the reference counter runs. When the wake-up timer reaches zero the reference counter is stopped, allowing software to read the number of 16 MHz clock ticks generated during the time represented by the number of 32 kHz ticks programmed in the wake-up timer. The true period of the 32 kHz clock can thus be determined and used when programming a wake-up timer to achieve a better accuracy and hence more accurate sleep periods

For an RC oscillator running at exactly 32000 Hz, the value returned by the calibration procedure should be 10000, for a calibration period of twenty 32000 Hz clock periods. If the oscillator is running faster than 32000 Hz, then the count will be less than 10000; if running slower then the value will be higher. For a calibration count of 9000, indicating that the RC oscillator period is running at approximately 35 kHz, in order to time for a period of 2 seconds the timer should be loaded with 71,111 $((10000/9000) \times (32000 \times 2))$ rather than 64000.

9.10 Pulse counters

Two 16-pulse counters are provided that can increment during all modes of operation (including sleep). The first pulse counter, PC0, increments from pulses received on DIO1 or DIO4. The other pulse counter, PC1, operates from DIO5 or DIO8 depending upon the configuration. This is enabled under software control. The pulses can be de-bounced using the 32 kHz clock to guard against false counting on slow or noisy edges. Increments occur from a configurable rising or falling edge on the respective DIO input.

Each counter has an associated 16-bit reference that is loaded by the user. An interrupt (and wake-up event, if asleep) may be generated when a counter reaches its pre-configured reference value. The two counters may optionally be cascaded together to provide a single 32-bit counter, linked to any of the four DIOs. The counters do not saturate at 65535, but naturally roll-over to 0. Additionally, the pulse counting continues when the reference value is reached without software interaction so that pulses are not missed even if there is a long delay before an interrupt is serviced or during the wake-up process.

The system can work with signals of up to 100 kHz with no debounce, or from 5.3 kHz to 1.7 kHz with debounce. When using debounce the 32 kHz clock must be active, so for minimum sleep currents the debounce mode should not be used.

9.11 Serial communications

The JN5169 has two Universal Asynchronous Receiver/Transmitter (UART) serial communication interfaces. These provide similar operating features to the industry standard 16550A device operating in FIFO mode. The interfaces perform serial-to-parallel conversion on incoming serial data and parallel-to-serial conversion on outgoing data from the CPU to external devices. In both directions, a configurable FIFO buffer (with a default depth of 16-byte) allows the CPU to read and write multiple characters on each transaction. This means that the CPU is freed from handling data on a character-by-character basis, with the associated high processor overhead. The UARTs have the following features:

- Emulates behavior of industry standard NS16450 and NS16550A UARTs
- Configurable transmit and receive FIFO buffers (with default depths of 16 bytes for each), with direct access to fill levels of each. Adds/deletes standard start, stop and parity bits to/from the serial data
- Independently controlled transmit, receive, status and data sent interrupts
- Optional modem flow control signals CTS and RTS on UART0
- Fully programmable data formats: baud rate, start, stop and parity settings
- False start-bit detection, parity, framing and FIFO overrun error detect and break indication

- Internal diagnostic capabilities: loopback controls for communications link fault isolation
- Flow control by software or automatically by hardware

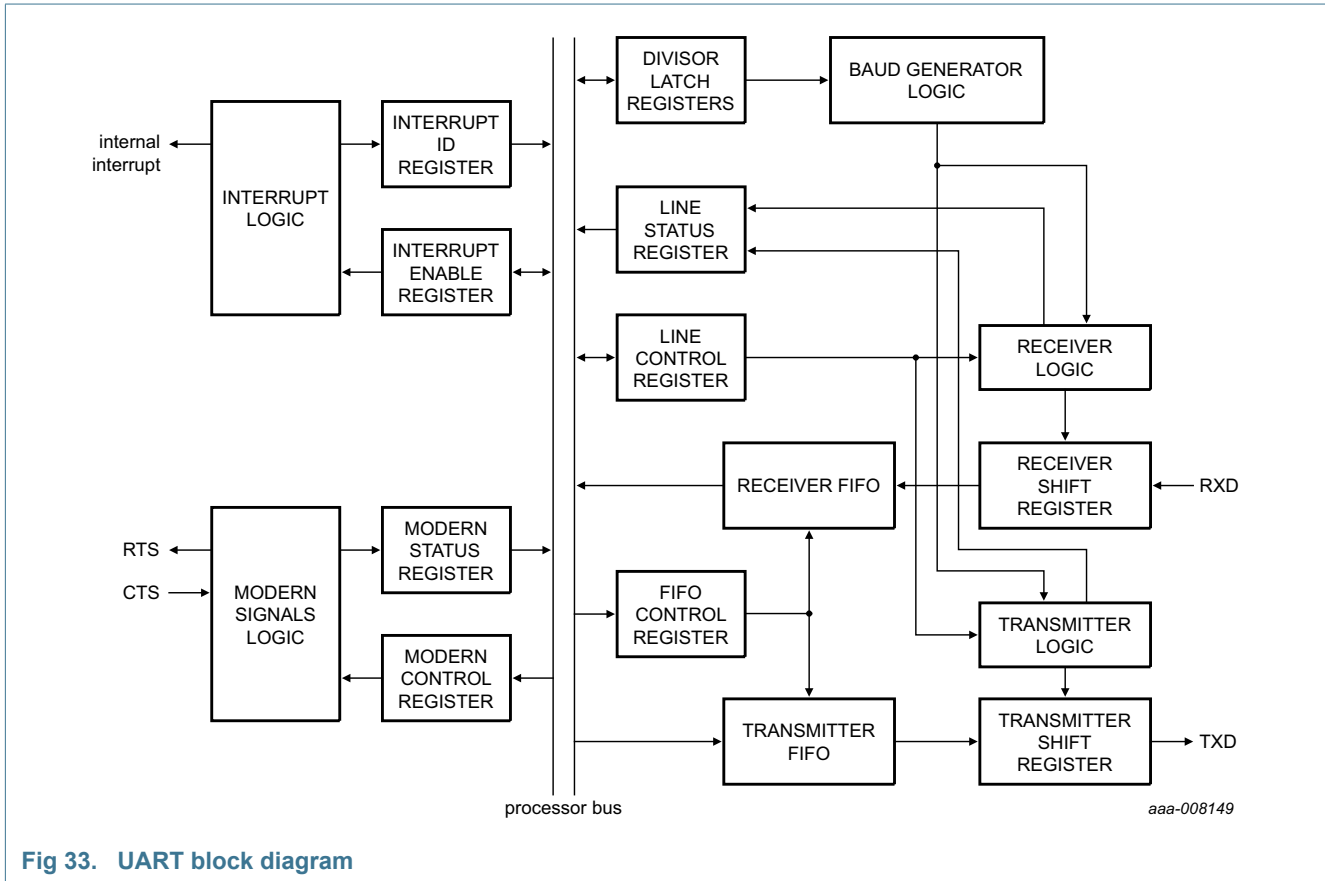

Fig 33. UART block diagram

The serial interfaces contain programmable fields that can be used to set number of data bits (5, 6, 7 or 8), even, odd, set-at-1, set-at-0 or no-parity detection and generation of single or multiple stop bit (for 5-bit data, multiple is 1.5 stop bits; for 6 data bits or 7 data bits or 8 data bits, multiple is 2 bits).

The baud rate is programmable up to 1 Mbits/s, e.g. 4.8 kbits/s, 9.6 kbits/s, 19.2 kbits/s, 38.4 kbits/s.

For applications requiring hardware flow control, UART0 provides two control signals: Clear-To-Send (CTS) and Request-To-Send (RTS). CTS is an indication sent by an external device to the UART that it is ready to receive data. RTS is an indication sent by the UART to the external device that it is ready to receive data. RTS is controlled from software activities, while the value of CTS can be read. Monitoring and control of CTS and RTS are software activity, normally performed as part of interrupt processing. The signals do not control parts of the UART hardware, but simply indicate to software the state of the UART external interfaces. Alternatively, the automatic flow control mode can be used, in which the hardware controls the value of the generated RTS (negated if the receive FIFO fill level is greater than a programmable threshold of 8 bytes, 11 bytes, 13 bytes or 15 bytes), and only transmits data when the incoming CTS is asserted.

Software can read characters, one byte at a time, from the receive FIFO and can also write to the transmit FIFO, one byte at a time. The transmit and receive FIFOs can be cleared and reset independently of each other. The status of the transmit FIFO can be checked to see if it is empty and if there is a character being transmitted. The status of the receive FIFO can also be checked, indicating if a condition such as parity error, framing error or break indication has occurred. It also shows if an overrun error has occurred (receive buffer full and another character arrives) and if there is data held in the receive FIFO.

UART0 and UART1 can both be configured to use standard or alternative DIO lines, as shown in [Table 8](#). Additionally, UART0 can be configured to be used in 2-wire mode (where CTS0 and RTS0 are not configured), and UART1 can be configured in 1-wire mode (where RXD1 is not configured). These freed up DIO pins can then be used for other purposes.

Table 8. UART I/O

Signal	DIO assignment	
	Standard pins	Alternative pins
CTS0	DIO4	DIO12
RTS0	DIO5	DIO13
TXD0	DIO6	DIO14
RXD0	DIO7	DIO15
TXD1	DIO14	DIO11
RXD1	DIO15	DIO9

Remark: With the automatic flow control threshold set to 15, the hardware flow control within the UART's block negates RTS when the Receive FIFO is about to become full. In some instances, it has been observed that remote devices that are transmitting data do not respond quickly enough to the de-asserted CTS and continue to transmit data. In these instances, the data will be lost in a receive FIFO overflow

9.11.1 Interrupts

Interrupt generation can be controlled for the UART's block and is divided into four categories:

- Received Data Available: set when data in the RX FIFO queue reaches a particular level (the trigger level can be configured as 1, 4, 8 or 14) or if no character has been received for 4-character times.
- Transmit FIFO Empty: set when the last character from the TX FIFO is read and starts to be transmitted
- Receiver Line Status: set when one of the following occurs
 - a. Parity Error - the character at the head of the receive FIFO has been received with a parity error
 - b. Overrun Error - the RX FIFO is full and another character has been received at the receiver shift register
 - c. Framing Error - the character at the head of the receive FIFO does not have a valid stop bit
 - d. Break Interrupt – occurs when the RXD line has been held low for an entire character

- Modem Status: generated when the CTS (Clear To Send) input control line changes.

9.11.2 UART application

The following example shows the UART0 connected to a 9-pin connector compatible with a PC. As the JN5169 device pins do not provide the RS232 line voltage, a level shifter is used.

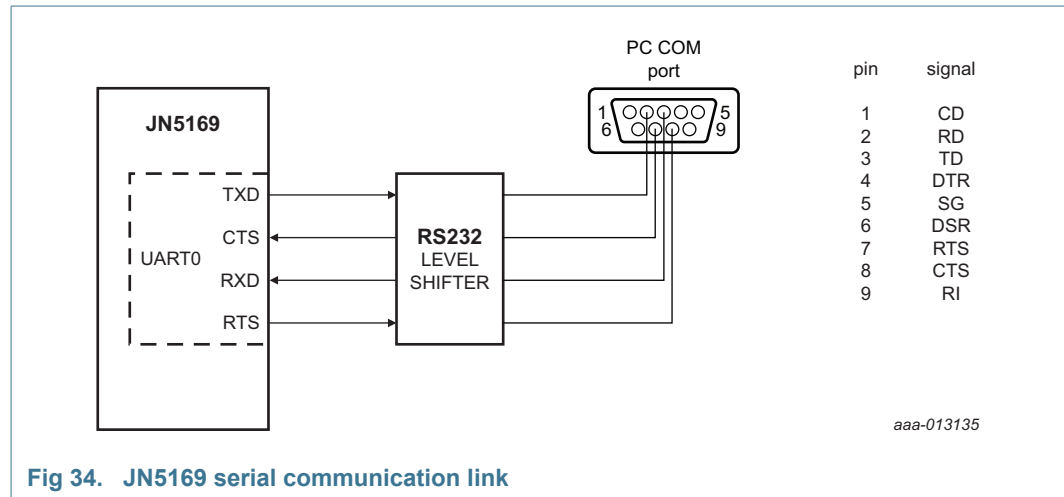

Fig 34. JN5169 serial communication link

9.12 JTAG test interface

The JN5169 includes a JTAG interface for the purposes of software debugging when used in conjunction with the BeyondStudio for NXP development environment.

For further details, see the Wireless Connectivity area of the NXP web site [Ref. 1](#).

The JTAG interface does not support boundary scan testing. It is recommended that the JN5169 is not connected as part of the board scan chain.

9.13 2-wire serial interface (I²C-bus)

The JN5169 includes an industry-standard I²C-bus 2-wire synchronous serial interface that can operate as a master (MSIF) or slave (SSIF), providing a simple and efficient method of data exchange between devices. The system uses a serial data line (SIF_D) and a serial clock line (SIF_CLK) to perform bidirectional data transfers and includes the following features.

Common to both master and slave:

- Compatible with both I²C-bus and SMBus peripherals
- Support for 7-bit and 10-bit addressing modes
- Optional pulse suppression on signal inputs (60 ns guaranteed, 125 ns typical)

Master only:

- Multi-master operation
- Software-programmable clock frequency
- Clock stretching and wait state generation

- Software-programmable acknowledge bit
- Interrupt or bit-polling driven byte-by-byte data-transfers
- Bus busy detection

Slave only:

- 2 programmable slave addresses
- General call in 7-bit addressing
- Simple byte-level transfer protocol
- Write data flow control with optional clock stretching or acknowledge mechanism
- Read data preloaded or provided as required.

The serial interface is accessed, depending upon the configuration, DIO14 and DIO15 or DIO16 and DIO17. This is enabled under software control. The following table details which DIOs are used for the serial interface depending upon the configuration.

Table 9. 2-wire serial interface I/O

Signal	DIO assignment	
	Standard pins	Alternative pins
SIF_CLK	DIO14	DIO16
SIF_D	DIO15	DIO17

9.13.1 Connecting devices

The clock and data lines, SIF_D and SIF_CLK, are alternative functions of DIO15 and DIO14 respectively. The serial interface function of these pins is selected when the interface is enabled. They are both bidirectional lines, connected internally to the positive supply voltage via weak (50 k Ω) programmable pull-up resistors. However, it is recommended that external 4.7 k Ω pull-ups be used for reliable operation at high bus speeds, as shown in [Figure 35](#). When the bus is free, both lines are HIGH. The output stages of devices connected to the bus must have an open-drain or open-collector in order to perform the wired-AND function. The number of devices connected to the bus is solely dependent on the bus capacitance limit of 400 pF.

As this is an optional interface with two alternative positions, the DIO cells have not been customized for I²C-bus operation. In particular, note that there are ESD diodes to the nominal 3 volt supply (V_{DD}) from the SIF_CLK and SIF_D pins. Therefore, if the V_{DD} supply is removed from the JN5169 and this then discharges to ground, a path would exist that could pull down the bus lines (see [Section 8.2.6](#)).

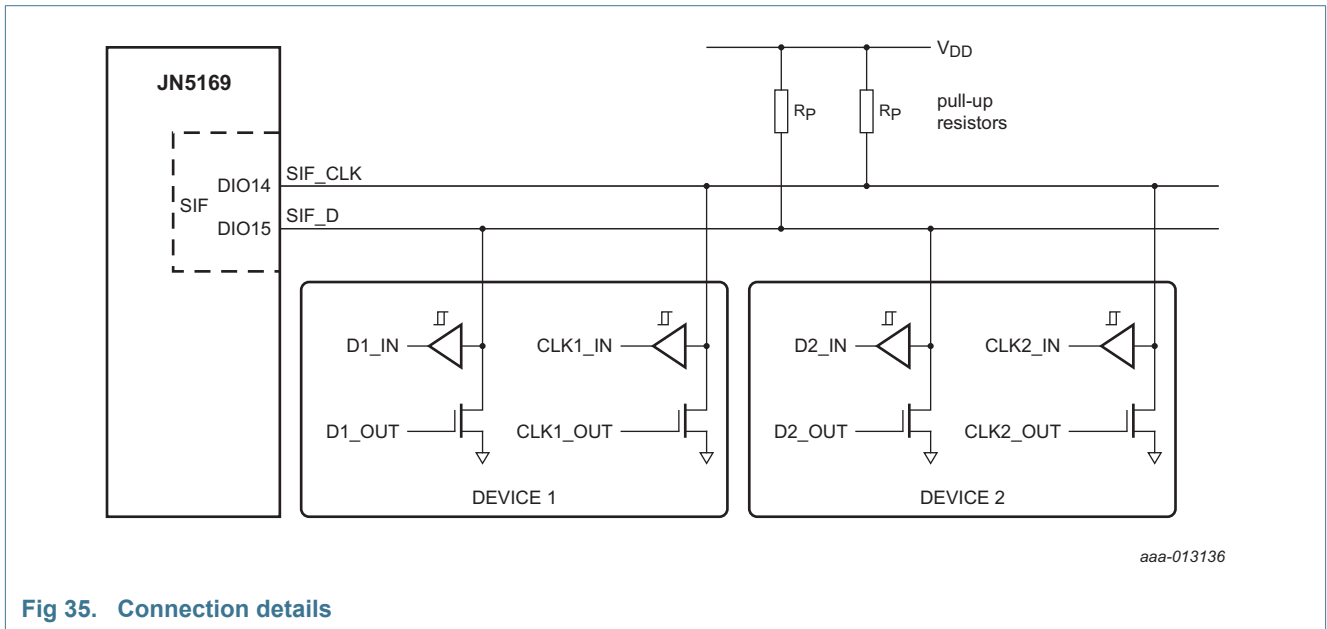

Fig 35. Connection details

9.13.2 Clock stretching

Slave devices can use clock stretching to slow down the read transfer bit-rate. After the master has driven SIF_CLK low, the slave can drive SIF_CLK low for the required period and then release it. If the slave's SIF_CLK low period is greater than the master's low period, then the resulting SIF_CLK bus signal low period is stretched, thus inserting wait states.

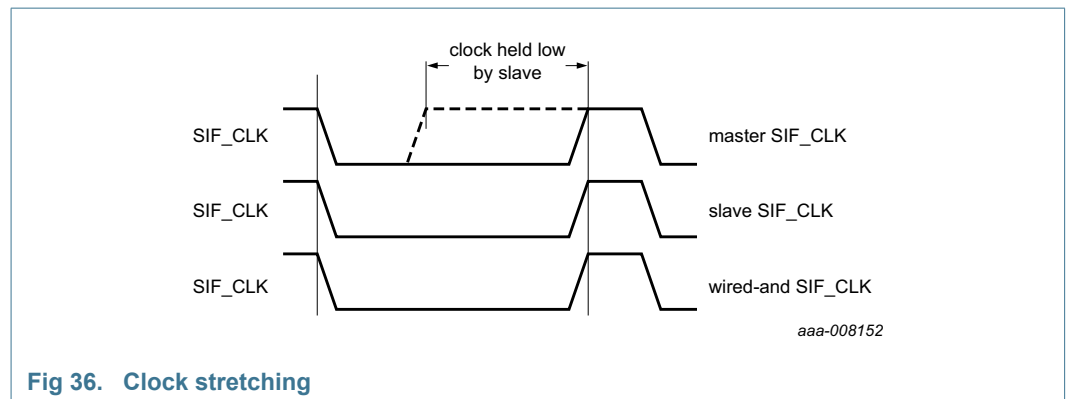

Fig 36. Clock stretching

9.13.3 Master 2-wire serial interface

When operating as a master device, the 2-wire serial interface provides the clock signal and a prescale register determines the clock rate, allowing operation up to 400 kbit/s.

Data transfer is controlled from the processor bus interface at a byte level, with the processor responsible for indicating when start, stop, read, write and acknowledge control should be generated. Data written into a transmit buffer will be transferred out across the 2-wire interface when prompted. Data received on the interface is made available in a receive buffer from where it can be read. The completion of a particular transfer may be indicated by means of an interrupt or detected by polling a status bit.

The first byte of data transferred by the device after a start bit is the slave address. The JN5169 supports both 7-bit and 10-bit slave addresses by generating either one or two address transfers. Only the slave with a matching address will respond by returning an acknowledge bit.

The master interface provides a true multi-master bus including collision detection and arbitration that prevents data corruption. If two or more masters simultaneously try to control the bus, a clock synchronization procedure determines the bus clock. Because of the wired-AND connection of the interface, a high-to-low transition on the bus affects all connected devices. This means a high-to-low transition on the SIF_CLK line causes all concerned devices to count off their low period. Once the clock input of a device has gone low, it will hold the SIF_CLK line in that state until the clock high state is reached when it releases the SIF_CLK line. Due to the wired-AND connection, the SIF_CLK line will therefore be held low by the device with the longest low period, and held high by the device with the shortest high period.

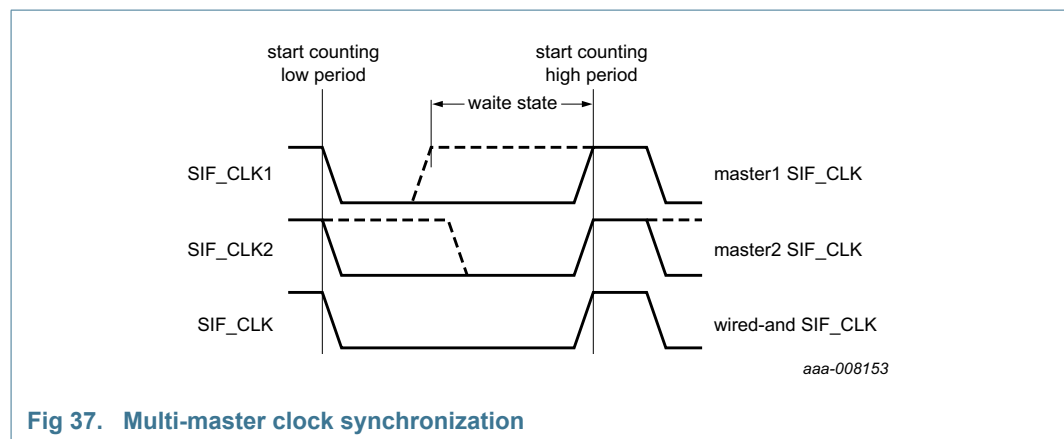

Fig 37. Multi-master clock synchronization

After each transfer has completed, the status of the device must be checked to ensure that the data has been acknowledged correctly, and that there has been no loss of arbitration.

Remark: Loss of arbitration may occur at any point during the transfer, including data cycles. An interrupt will be generated when arbitration has been lost.

9.13.4 Slave 2-wire serial interface

When operating as a slave device, the 2-wire serial interface does not provide a clock signal, although it may drive the clock signal low if it is required to apply clock stretching.

The interface allows both 7-bit and 10-bit addresses to be used. Only transfers which have an address that matches a value programmed into the interface’s Address register are accepted. This address match could be due to a general call access to either of the configurable 7-bit slave addresses or to the configurable 10-bit slave address. Addresses defined as “reserved” will not be responded to and should not be programmed into the Address register. A list of reserved addresses is shown in [Table 10](#).

Table 10. List of 2-wire serial interface reserved addresses

Address	Name	Behavior
0000 000	general call/start byte	responded if 7-bit addressing is set
0000 001	CBUS address	ignored
0000 010	reserved	ignored
0000 011	reserved	ignored
0000 1XX	HS-mode master code	ignored
1111 1XX	reserved	ignored
1111 0XX	10-bit address	only responded on first slave address if 10-bit address set in address register

Data transfer is controlled from the processor bus interface at a byte level, with the processor responsible for taking write data from a receive buffer and providing read data to a transmit buffer when prompted. A series of interrupt status bits are provided to control the flow of data.

For writes into the slave interface, it is important that data is taken from the receive buffer by the processor before the next byte of data arrives. To enable this, the interface returns a Not Acknowledge (NACK) to the master if more data is received before the previous data has been taken. This will lead to the termination of the current data transfer.

For reads from the slave interface, the data may be preloaded into the transmit buffer when it is empty (i.e. at the start of day, or when the last data has been read), or fetched each time a read transfer is requested. When using data preload, read data in the buffer must be replenished following a data write, as the transmit and receive data is contained in a shared buffer. The interface will hold the bus using clock stretching when the transmit buffer is empty.

Interrupts may be triggered when:

- Data Buffer read data is required – a byte of data to be read should be provided to avoid the interface from clock stretching
- Data Buffer read data has been taken – this indicates when the next data may be preloaded into the data buffer
- Data Buffer write data is available – a byte of data should be taken from the data buffer to avoid data backoff as defined above
- The last data in a transfer has completed – i.e. the end of a burst of data, when a Stop or Restart is seen
- A protocol error has been spotted on the interface

9.14 Random number generator

A random number generator is provided which creates a 16-bit random number each time it is invoked. Consecutive calls can be made to build up any length of random number. Each call takes approximately 0.25 ms to complete. Alternatively, continuous generation mode can be used where a new number is generated approximately every 0.25 ms. In either mode of operation, an interrupt can be generated to indicate when the number is available, or a status bit can be polled.

The random bits are generated by sampling the state of the 32 MHz clock every 32 kHz system clock edge. As these clocks are asynchronous to each other, each sampled bit is unpredictable and hence random.

9.15 Analog peripherals

The JN5169 contains a number of analog peripherals allowing the direct connection of a wide range of external sensors and switches.

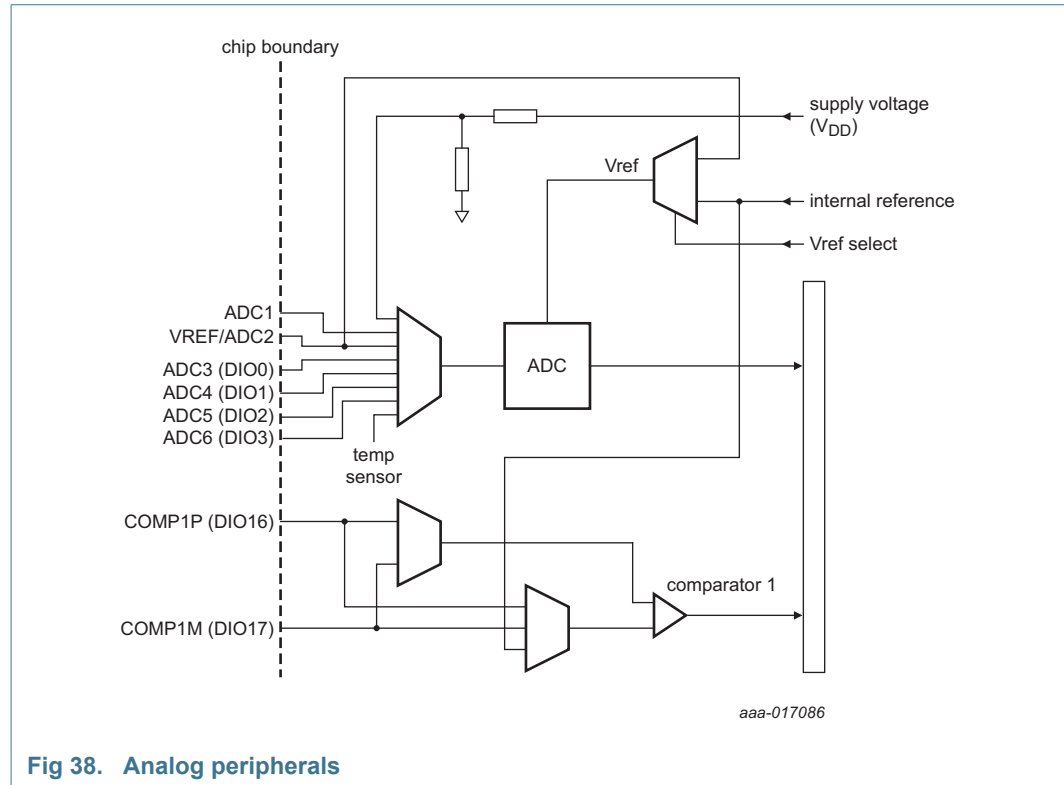

Fig 38. Analog peripherals

In order to provide good isolation from digital noise, the analog peripherals and radio are powered by the radio regulator, which is supplied from the analog supply V_{D_{DA}} and referenced to analog ground V_{S_{SA}}.

A reference signal V_{ref} for the ADC can be selected to be an internal band gap reference or an external voltage reference supplied to the VREF pin. ADC input 2 cannot be used if an external reference is required, as this uses the same pin as VREF. Note also that ADC3, ADC4, ADC5 and ADC6 use the same pins as DIO0, DIO1, DIO2 and DIO3 respectively. These pins can only be used for the ADC if they are not required for any of their alternative functions. Similarly, the comparator inputs are shared with DIO16 and DIO17. If used for their analog functions, these DIOs must be put into a passive state by configuring them as inputs with their pull-ups disabled.

The ADC is clocked from a common clock source derived from the 16 MHz clock.

9.15.1 Analog to Digital Converter (ADC)

The 10-bit ADC uses a successive approximation design to perform high accuracy conversions as typically required in wireless sensor network applications. It has 8 multiplexed single-ended input channels: 6 available externally, 1 connected to an internal temperature sensor, and 1 connected to an internal supply monitoring circuit.

9.15.1.1 Operation

The input range of the ADC can be set between 40 mV to either the reference voltage or twice the reference voltage. The reference can be either taken from the internal voltage reference or from the external voltage applied to the VREF pin. For example, an external reference of 1.2 V supplied to VREF may be used to set the ADC range between 40 mV and 2.4 V.

Table 11. ADC maximum input range

VREF	Gain setting	Maximum input range	Supply voltage range (V _{DD})
1.2 V	0	1.2 V	2.2 V to 3.6 V
1.6 V	0	1.6 V	2.2 V to 3.6 V
1.2 V	1	2.4 V	2.6 V to 3.6 V
1.6 V	1	3.2 V	3.4 V to 3.6 V

The input clock to the ADC is 16 MHz and can be divided down to 2 MHz, 1 MHz, 500 kHz or 250 kHz. During an ADC conversion, the selected input channel is sampled for a fixed period and then held. This sampling period is defined as a number of ADC clock periods and can be programmed to 2, 4, 6 or 8. The conversion period is $((3 \times \text{sample period}) + 13)$ clock periods. For example, for a 500 kHz conversion with a sample period of 2, the conversion period is $((3 \times 2) + 13) = 19$ clock periods, which is equal to 38 μs and equivalent to a conversion rate of 26.32 kHz. The ADC can be operated in either a single conversion mode or alternatively a new conversion can be started as soon as the previous one has completed, to give continuous conversions.

If the source resistance of the input voltage is 1 kΩ or less, then the default sampling time of 2 clocks should be used. The input to the ADC can be modeled as a resistor of 5 kΩ (typ.) and 10 kΩ (max.) to represent the on-resistance of the switches and the sampling capacitor 8 pF. The sampling time required can then be calculated by adding the sensor source resistance to the switch resistance, multiplying by the capacitance to give a time constant. Assuming normal exponential RC charging, the number of time constants required to give an acceptable error can be calculated; 7-time constants gives an error of 0.091 %, so for 10-bit accuracy 7 time constants should be the target. For a source with zero resistance, 7-time constant is 640 ns, hence the smallest sampling window of 2 clock periods can be used.

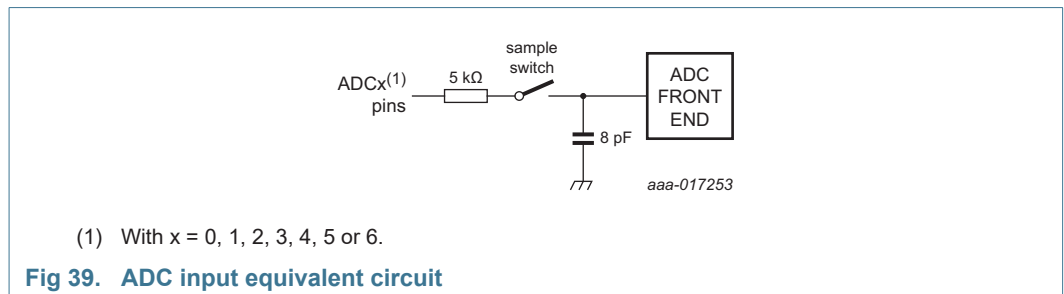

The ADC sampling period, input range and mode (single-shot or continuous) are controlled through software.

When the ADC conversion is complete, an interrupt is generated. Alternatively the conversion status can be polled. When operating in continuous mode, it is recommended that the interrupt is used to signal the end of a conversion, since conversion times may range from 9.5 μ s to 148 μ s. Polling over this period would be wasteful of processor bandwidth.

To facilitate the averaging of the ADC values, which is common practice in microcontrollers, a dedicated accumulator has been added. The user can configure the accumulation to occur over 2, 4, 8 or 16 samples. The end of conversion interrupt can be modified to occur at the end of the chosen accumulation period. Alternatively polling can still be used. Software can then be used to apply the appropriate rounding and shifting to generate the average value, as well as setting up the accumulation function.

For detailed electrical specifications, see [Section 14.3.7](#).

9.15.1.2 Supply monitor

The internal supply monitor allows the voltage on the analog supply pin V_{DDA} to be measured. This is achieved with a potential divider that scales the voltage by a factor of 0.666, allowing it to fall inside the input range of the ADC when set with an input range twice the internal voltage reference. The resistor chain that performs the voltage reduction is disabled until the measurement is made to avoid a continuous drain on the supply.

9.15.1.3 Temperature sensor

The on-chip temperature sensor can be used either to provide an absolute measure of the device temperature or to detect changes in the ambient temperature. In common with most on-chip temperature sensors, it is not trimmed and so the absolute accuracy variation is large; the user may wish to calibrate the sensor prior to use. The sensor forces a constant current through a forward biased diode to provide a voltage output proportional to the chip die temperature which can then be measured using the ADC. The measured voltage has a linear relationship to temperature as described in [Section 14.3.13](#).

Because this sensor is on-chip, any measurements taken must account for the thermal time constants. For example, if the device just came out of sleep or deep sleep mode, the user application should wait until the temperature has stabilized before taking a measurement.

9.15.1.4 ADC sample buffer mode

In this mode, the ADC operates in conjunction with a Direct Memory Access (DMA) engine as follows:

- ADC sampling is triggered at a configurable rate using one of the on-chip timers (TimerX, where X = 1, 2, 3 or 4)
- ADC samples are automatically stored in a buffer located in RAM using a DMA mechanism
- ADC inputs may be multiplexed between different analog sources

The 10-bit ADC data samples are transferred into the buffer in RAM as 16-bit words. The maximum number of 16-bit words that may be allocated in RAM for ADC sample storage is 2047.

The buffer may be configured to automatically wrap around to the start when full. Interrupts may be configured to indicate when the buffer is half-full, full or has overflowed.

The CPU may perform other tasks while the data transfer and storage is being managed independently by the DMA engine - the CPU only needs to configure the ADC sample buffer mode and deal with the stored samples in the buffer when an interrupt occurs.

ADC sample buffer mode allows up to eight analog inputs to be multiplexed in combination. These inputs comprise six external inputs (ADC1 to 6, corresponding to IO pins), an on-chip temperature sensor and an internal voltage monitor. Samples from all the selected inputs will be produced on each timer trigger and stored in consecutive RAM locations.

9.15.2 Comparator

The JN5169 contains one analog comparator, COMP1, that is designed to have true rail-to-rail inputs and operate over the full voltage range of the analog supply V_{DDA} . The hysteresis level can be set to a nominal value of 0 mV, 10 mV, 20 mV or 40 mV. The source of the negative input signal for the comparator can be set to the internal voltage reference, the negative external pin (COMP1M, which uses the same pin as DIO17) or the positive external pin (COMP1P, on the same pin as DIO16). The source of the positive input signal can be COMP1P or COMP1M. DIO16 and DIO17 cannot be used if the external comparator inputs are needed. The comparator output is routed to an internal register and can be polled, or can be used to generate interrupts. The comparator can be disabled to reduce power consumption. DIO16 and DIO17 should be configured as inputs with pull-ups disabled when using the comparator.

The comparator also has a low-power mode in which the response time of the comparator is slower in the normal mode, but the current required is greatly reduced. These figures are specified in [Section 14.3.8](#). It is the only mode that may be used during sleep, where a transition of the comparator output will wake the device. The wake-up action and the configuration of which edge of the comparator output will be active are controlled through software. In sleep mode, the negative input signal source must be configured to be driven from the external pins.

10. Power management and sleep modes

10.1 Operating modes

Three operating modes are provided in the JN5169 that enable the system power consumption to be controlled carefully to maximize battery life.

- Active processing mode
- Sleep mode
- Deep sleep mode

The variation in power consumption of the three modes is a result of having a series of power domains within the chip that may be controllably powered ON or OFF.

10.1.1 Power domains

The JN5169 has the following power domains:

- V_{DD} supply domain: supplies the wake-up timers and controller, DIO blocks, comparator, SVM and BOR plus Fast RC, 32 kHz RC and crystal oscillators. This domain is driven from the external supply (battery) and is always powered. The wake-up timers and controller, and the 32 kHz RC and crystal oscillators may be powered ON or OFF in sleep mode through software control.
- Digital logic domain: supplies the digital peripherals, CPU, Flash memory, RAM (when in active processing mode), baseband controller, modem and encryption processor. It is powered off during sleep mode.
- RAM domain: supplies the RAM when in active processing mode. Also supplies the RAM during sleep mode to retain the memory contents. It may be powered ON or OFF for sleep mode through software control.
- Radio domain: supplies the radio interface, ADCs and temperature sensor. It is powered during transmission and reception and when the analog peripherals are enabled. It is controlled by the baseband processor and is powered OFF during sleep mode.

The current consumption figures for the different modes of operation of the device are given in [Section 14.1](#).

10.2 Active processing mode

Active processing mode in the JN5169 is where all of the application processing takes place. By default, the CPU will execute application firmware at the selected clock speed. All of the peripherals are available to the application, as are options to actively enable or disable them to control power consumption; see specific peripheral sections for details.

While in active processing mode there is the option to doze the CPU but keep the rest of the chip active; this is particularly useful for radio transmit and receive operations, where the CPU operation is not required, therefore saving power.

10.2.1 CPU doze

While in doze mode, CPU operation is stopped but the chip remains powered and the digital peripherals continue to run. Doze mode is entered through software and is terminated by any interrupt request. Once the interrupt service routine has been executed, normal program execution resumes. Doze mode uses more power than sleep and deep sleep modes but requires less time to restart and can therefore be used as a low-power alternative to an idle loop.

While in CPU doze, the CPU is not drawing current and therefore the basic device current is reduced.

10.3 Sleep mode

The JN5169 enters sleep mode through software control. In this mode, most of the internal chip functions are shut down to save power. However the states of the DIO pins are retained, including the output values and pull-up enables, and this therefore preserves any interface to the outside world.

When entering into sleep mode, there is an option to retain the RAM contents throughout the sleep period. If the wake-up timers are not to be used for a wake-up event and the application does not require them to run continually, power can be saved by switching off the 32 kHz oscillator if selected as the 32 kHz system clock through software control. The oscillator will be restarted when a wake-up event occurs.

While in sleep mode, one of four possible events can cause a wake-up to occur: transitions on DIO inputs, expiry of wake-up timers, pulse counters maturing or comparator events. If any of these events occur and the relevant interrupt is enabled, an interrupt is generated that will cause a wake-up from sleep. It is possible for multiple wake-up sources to trigger an event at the same instant but only one of them will be accountable for the wake-up period. It is therefore necessary in software to remove all other pending wake-up events prior to requesting entry back into sleep mode; otherwise, the device will reawaken immediately.

When wake-up occurs, a similar sequence of events to the reset process described in [Section 9.4](#) happens, including the checking of the supply voltage by the Supply Voltage Monitor ([Section 9.4.4](#)). The high-speed RC oscillator is started up and, once stable, the power to CPU system is enabled and the reset is removed. Software determines that this is a reset from sleep and so commences with the wake-up process. If RAM contents were held through sleep, wake-up is quicker as the software does not have to initialize RAM contents meaning the application can recommence more quickly. See [Section 14.3.5](#) for wake-up timings.

10.3.1 Wake-up timer event

The JN5169 contains two 41-bit wake-up timers that are counters clocked from the 32 kHz oscillator, and can be programmed to generate a wake-up event. Following a wake-up event, the timers continue to run. These timers are described in [Section 9.9.8](#). Timer events can be generated from both timers; one is intended for use by the IEEE802.15.4 protocol, the other being available for use by the application running on the CPU. These timers are available to run at any time, even during sleep mode.

10.3.2 DIO event

Any DIO pin when used as an input has the capability, by detecting a transition, to generate a wake-up event. Once this feature has been enabled, the type of transition can be specified (rising or falling edge). Even when groups of DIO lines are configured for alternative functions, such as the UARTs or timers, any input line in the group can still be used to provide a wake-up event. This means that an external device communicating over the UART can wake up a sleeping device by asserting its RTS signal pin (which is the CTS input of the JN5169).

10.3.3 Comparator event

The comparator can generate a wake-up interrupt when a change in the relative levels of the positive and negative inputs occurs. The ability to wake up when continuously monitoring analog signals is useful in ultra-low power applications. For example, the JN5169 can remain in sleep mode until the voltage drops below a threshold and then be woken up to deal with the alarm condition; the comparator has a low current mode to facilitate this.

10.3.4 Pulse counter

The JN5169 contains two 16-bit pulse counters that can be programmed to generate a wake-up event. Following the wake-up event the counters will continue to operate and therefore no pulse will be missed during the wake-up process. These counters are described in [Section 9.10](#). To minimize sleep current it is possible to disable the 32 kHz RC oscillator and still use the pulse counters to cause a wake-up event, provided debounce mode is not required.

10.4 Deep sleep mode

Deep sleep mode gives the lowest power consumption. All switchable power domains are off and most functions in the V_{DD} supply power domain are stopped, including the 32 kHz RC oscillator. However, the Brown-Out Reset remains active as well as all the DIO cells. This mode can be exited by a hardware reset on the RESET_N pin, or an enabled DIO or comparator wake-up event. In all cases, the wake-up sequence is equivalent to a power-up sequence, with no knowledge retained from the previous time the device was awake.

11. Limiting values

Table 12. Limiting values

In accordance with the Absolute Maximum Rating System (IEC 60134).

Symbol	Parameter	Conditions	Min	Max	Unit
V_{DDA}	analog supply voltage		-0.3	+3.6	V
V_{DDD}	digital supply voltage		-0.3	+3.6	V
$V_{DD(\text{regd})}$	regulated supply voltage	on pins VB_xx [1]	-0.3	+1.98	V
V_{XTAL_OUT}	voltage on pin XTAL_OUT	[1]	-0.3	VB_xx + 0.3	V
V_{XTAL_IN}	voltage on pin XTAL_IN	[1]	-0.3	VB_xx + 0.3	V
V_{RF_IO}	voltage on pin RF_IO	[1]	-0.3	VB_xx + 0.3	V
V_{VREF}	voltage on pin VREF		-0.3	$V_{DDA} + 0.3$	V
V_{ADC1}	voltage on pin ADC1		-0.3	$V_{DDA} + 0.3$	V
V_{IBIAS}	voltage on pin IBIAS		-0.3	$V_{DDA} + 0.3$	V
$V_{IO(\text{dig})}$	digital input/output voltage		-0.3	$V_{DDD} + 0.3$	V
T_{stg}	storage temperature		-40	+150	°C
V_{ESD}	electrostatic discharge voltage	HBM [2]	-	2000	V
		CDM [3]	-	1000	V

[1] With xxx = SYNTH or VCO or RF2 or RF1 or DIG.

[2] Testing for HBM discharge is performed as specified in JEDEC Standard JS-001.

[3] Testing for CDM discharge is performed as specified in JEDEC Standard JESD22-C101.

12. Recommended operating conditions

Table 13. Operating conditions

Symbol	Parameter	Conditions	Min	Max	Unit
V _{DDA}	analog supply voltage	[1]	2	3.6	V
V _{DDD}	digital supply voltage		2	3.6	V
T _{amb}	ambient temperature	standard range	-40	+125	°C

[1] To reach the maximum TX power, 2.8 V is the minimum.

13. Thermal characteristics

Table 14. Thermal characteristics

Symbol	Parameter	Conditions	Min	Typ	Max	Unit
R _{th(j-a)}	thermal resistance from junction to ambient		-	29.9	-	K/W
R _{th(j-c)}	thermal resistance from junction to case		-	19	-	K/W
T _{j(max)}	maximum junction temperature		-	-	130	°C

14. Characteristics

14.1 DC current

Table 15. Active processing

V_{DD} = 2 V to 3.6 V; T_{amb} = -40 °C to +125 °C; unless otherwise specified.

Symbol	Parameter	Conditions	Min	Typ	Max	Unit	
I _{DD}	supply current	CPU in doze mode; analog and digital [1]					
		with radio in receive mode; maximum input level at 10 dBm; high-performance mode	-	15	-	mA	
		with radio in receive mode; maximum input level at 10 dBm; high-performance mode; V _{DD} = 3 V; T _{amb} = 25 °C	-	14.7	-	mA	
		with radio in receive mode; maximum input level at 0 dBm; low-power mode	-	13	-	mA	
		with radio in transmit mode 10 dBm [2]	-	23.3	-	mA	
		with radio in transmit mode 8.5 dBm [2]	-	19.6	-	mA	
		with radio in transmit mode 3 dBm	-	14	-	mA	
		without radio	-	2	-	mA	
		CPU processing at: [3]					
		32 MHz	-	5.7	-	mA	
		16 MHz	-	3.1	-	mA	
		8 MHz	-	1.8	-	mA	
		4 MHz	-	0.9	-	mA	
		2 MHz	-	0.5	-	mA	
1 MHz	-	0.4	-	mA			
I _{I(ADC)}	ADC input current	[4] [5]	-	400	-	μA	

Table 15. Active processing ...continued $V_{DD} = 2\text{ V to }3.6\text{ V}$; $T_{amb} = -40\text{ °C to }+125\text{ °C}$; unless otherwise specified.

Symbol	Parameter	Conditions	Min	Typ	Max	Unit
$I_{DD(comp)}$	comparator supply current	[5]				
		operating mode	-	73	-	μA
		low-power mode	-	0.8	-	μA
$I_{DD(UART)}$	UART supply current	per UART [5]	-	60	-	μA
$I_{DD(tmr)}$	timer supply current	per timer [5]	-	60	-	μA
$I_{DD(sintf)}$	serial interface supply current	[5]	-	50	-	μA

[1] Doze mode = CPU is not clocked.

[2] To reach the maximum TX power, 2.8 V is the minimum.

[3] Digital consumption only. When in CPU doze, the current related to CPU speed is not consumed. This value should be added to the CPU in doze mode supply current value.

[4] Temperature sensor and battery measurements require ADC.

[5] These numbers should be added to I_{DD} if the feature is being used.

Table 16. Sleep mode $V_{DD} = 2\text{ V to }3.6\text{ V}$; $T_{amb} = -40\text{ °C to }+125\text{ °C}$; unless otherwise specified.

Symbol	Parameter	Conditions	Min	Typ	Max	Unit
$I_{DDD(IO)}$	input/output digital supply current	in sleep mode; with I/O wake-up; $T_{amb} = 25\text{ °C}$ [1] [2]	-	0.10	-	μA
		in sleep mode; with I/O and RC oscillator timer wake-up; $T_{amb} = 25\text{ °C}$	-	0.73	-	μA
$I_{DD(xtal)}$	crystal oscillator supply current	for 32 kHz crystal oscillator	-	0.6	-	μA
$I_{ret(RAM)}$	RAM retention current	$T_{amb} = 25\text{ °C}$ [3]	-	0.7	-	μA
$I_{DD(comp)}$	comparator supply current	low-power mode [3] [4]	-	0.8	-	μA

[1] Waiting on I/O event.

[2] Analog peripherals consumption to add.

[3] RAM and comparator supply currents should be added to $I_{DDD(IO)(sleep)}$ if the feature is being used.

[4] Reduced response time.

Table 17. Deep sleep mode $V_{DD} = 2\text{ V to }3.6\text{ V}$; $T_{amb} = -40\text{ °C to }+125\text{ °C}$; unless otherwise specified.

Symbol	Parameter	Conditions	Min	Typ	Max	Unit
I_{DDD}	digital supply current	deep sleep mode; measured at 25 °C [1]	-	50	-	nA

[1] Waiting on chip RESET or I/O event.

14.2 I/O characteristics

Table 18. I/O characteristics

$V_{DD} = 2\text{ V to }3.6\text{ V}$; $T_{amb} = -40\text{ }^{\circ}\text{C to }+125\text{ }^{\circ}\text{C}$; unless otherwise specified.

Symbol	Parameter	Conditions	Min	Typ	Max	Unit
$R_{pu(int)(DIO)}$	internal pull-up resistance on pins DIOx ^[1]		40	50	60	k Ω
$R_{pu(int)(RESET_N)}$	internal pull-up resistance on pin RESET_N	$V_{DD} = 3.6\text{ V}$	300	425	550	k Ω
		$V_{DD} = 3.0\text{ V}$	400	500	700	k Ω
		$V_{DD} = 2.2\text{ V}$	650	830	1100	k Ω
		$V_{DD} = 2.0\text{ V}$	750	950	1350	k Ω
Digital voltages						
I/O						
V_{IH}	HIGH-level input voltage		$0.7V_{DD}$	-	V_{DD}	V
V_{IL}	LOW-level input voltage		-0.3	-	$0.27V_{DD}$	V
$V_{hys(i)}$	input hysteresis voltage		200	310	400	mV
Output on pins DIOx ^[1]						
V_{OH}	HIGH-level output voltage	6.8 mA load	$V_{DD} - 0.4$	-	V_{DD}	V
V_{OL}	LOW-level output voltage	6.8 mA load	0	-	0.4	V
Currents						
I_{LIL}	LOW-level input leakage current	$V_{DD} = 3.6\text{ V}$; $T_{amb} = 25\text{ }^{\circ}\text{C}$	-	2	-	nA
I_{LIH}	HIGH-level input leakage current	$V_{DD} = 3.6\text{ V}$; $T_{amb} = 25\text{ }^{\circ}\text{C}$	-	2	-	nA

[1] With x = 0, 1, 2, 3, 4, 5, 6, 7, 8, 9, 10, 11, 12, 13, 14, 15, 16, 17, 18 or 19.

14.3 AC characteristics

14.3.1 Reset and Supply Voltage Monitor

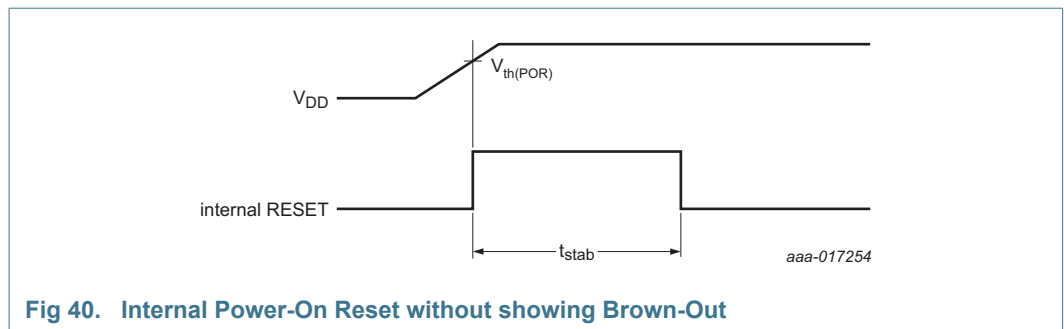

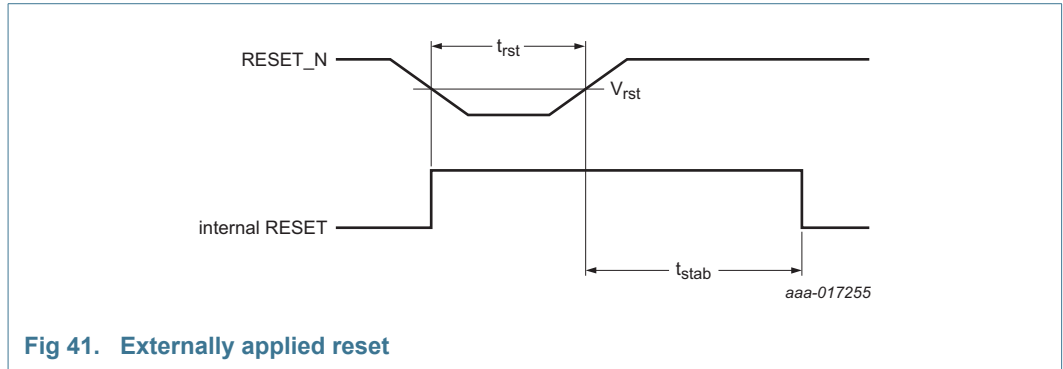

Fig 41. Externally applied reset

Table 19. Externally applied reset

Symbol	Parameter	Conditions	Min	Typ	Max	Unit
t_{rst}	reset time	external reset pulse width to initiate reset sequence	[1] 1	-	-	μs
V_{rst}	reset voltage	external threshold voltage	[2] $0.7V_{DD}$	-	-	V
$V_{th(POR)}$	power-on reset threshold voltage	rise time > 10 ms				
		rising	-	1.44	-	V
		falling	-	1.41	-	V
α_{spike}	spike rejection	depth of pulse to trigger reset				
		1 μs square wave	-	1.2	-	V
		10 μs triangular wave	-	1.3	-	V
t_{stab}	stabilization time	reset	[3] -	180	-	μs
I_{DD}	supply current	chip current when held in reset	-	6	-	μA
$I_{rst(bo)}$	brownout reset current		-	80	-	nA
V_{th}	threshold voltage	supply threshold voltage monitor; configurable in eight levels	1.86	1.94	2.00	V
			1.92	2.00	2.06	V
			2.02	2.10	2.16	V
			2.11	2.20	2.27	V
			2.21	2.30	2.37	V
			2.30	2.40	2.47	V
			2.59	2.70	2.78	V
			2.88	3.00	3.09	V
V_{hys}	hysteresis voltage	supply voltage monitor; corresponding to the eight threshold levels	-	37	-	mV
			-	38	-	mV
			-	45	-	mV
			-	52	-	mV
			-	58	-	mV
			-	65	-	mV
			-	82	-	mV
			-	100	-	mV

- [1] Assumes internal pull-up resistor value of 100 kΩ worst case and ≈5 pF external capacitance.
- [2] Minimum voltage to avoid being reset.
- [3] Time from release of reset to start of executing of bootloader code from internal Flash. An extra 15 μs is incurred if the BOR circuit has been activated (e.g. if the supply voltage has been ramped up from 0 V).

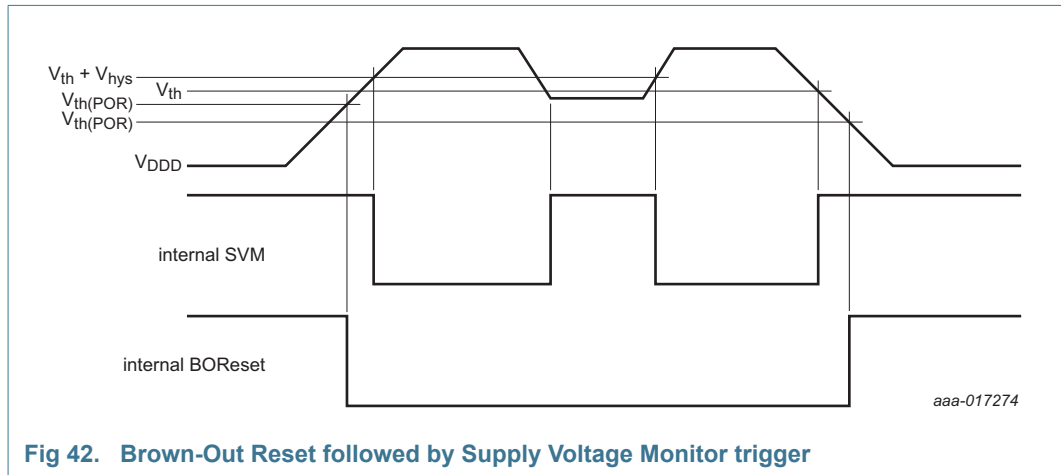

Fig 42. Brown-Out Reset followed by Supply Voltage Monitor trigger

14.3.2 SPI-bus master timing

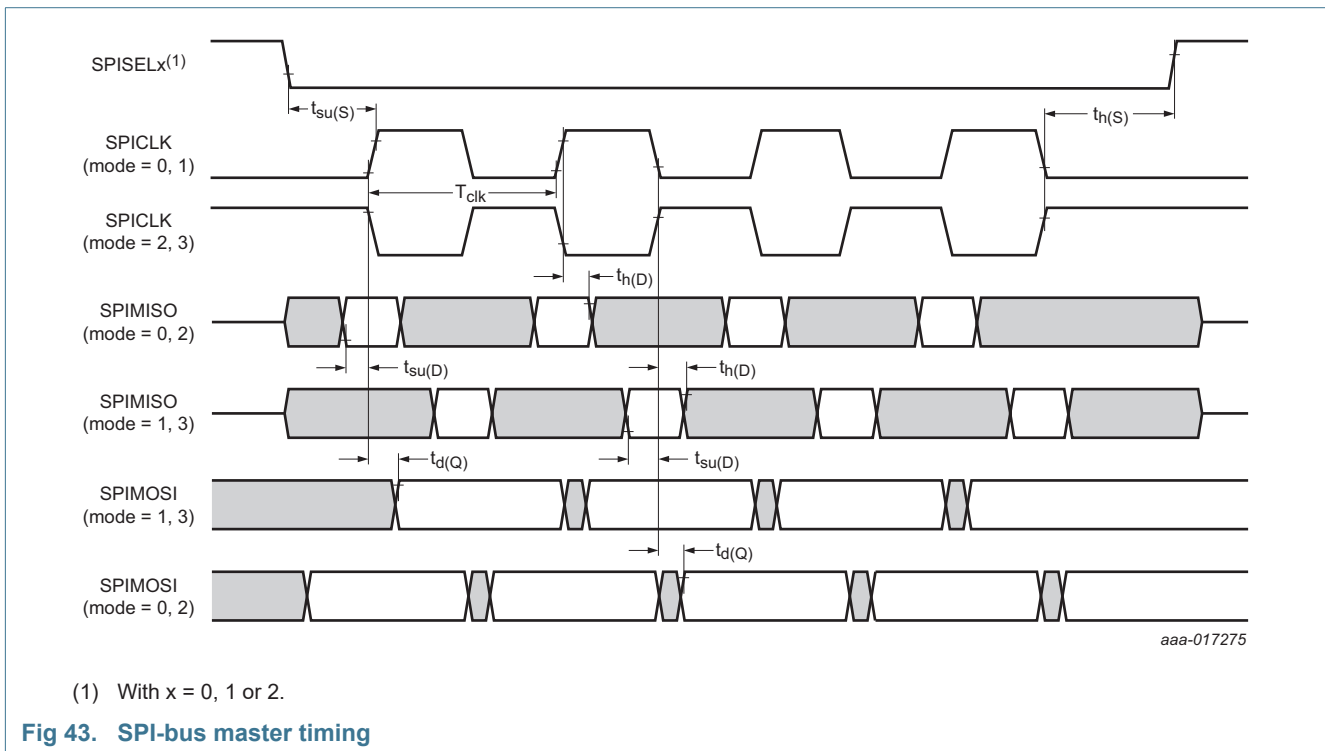

Fig 43. SPI-bus master timing

Table 20. SPI-bus master timing

Symbol	Parameter	Conditions	Min	Typ	Max	Unit
T_{clk}	clock period		62.5	-	-	ns
$t_{su(D)}$	data input set-up time	3.3 V	12.5	-	-	ns
		2.7 V	13	-	-	ns
		2.0 V	14	-	-	ns
$t_{h(D)}$	data input hold time		0	-	-	ns
$t_{d(Q)}$	data output delay time	on SPIMOSI	-	-	15	ns
$t_{su(S)}$	chip select set-up time		60	-	-	ns
$t_{h(S)}$	chip select hold time	SPICLK = 16 MHz	30	-	-	ns
		SPICLK < 16 MHz; mode = 0 or 2	0	-	-	ns
		SPICLK < 16 MHz; mode = 1 or 3	60	-	-	ns

14.3.3 SPI-bus slave timing

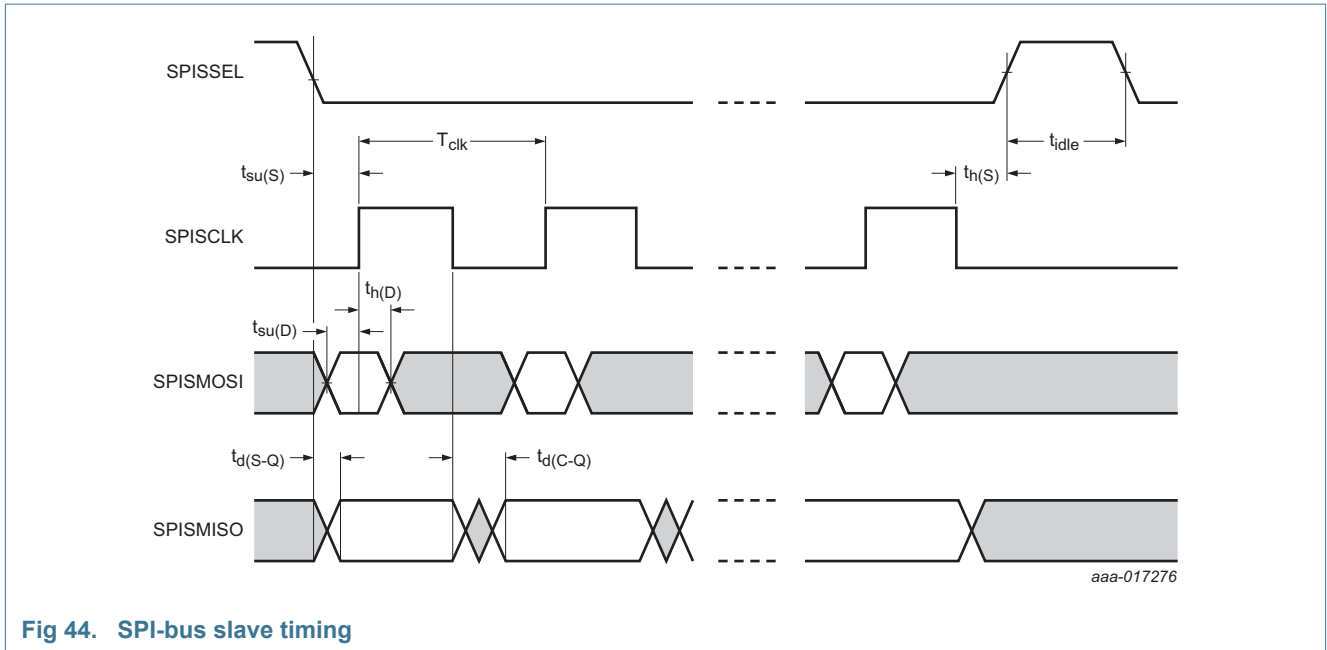

Fig 44. SPI-bus slave timing

Table 21. SPI-bus slave timing

Symbol	Parameter	Conditions	Min	Typ	Max	Unit
T_{clk}	clock period		125	-	-	ns
t_{idle}	idle time		125	-	-	ns
$t_{su(D)}$	data input set-up time		10	-	-	ns
$t_{h(D)}$	data input hold time		10	-	-	ns
$t_{d(C-Q)}$	clock to data output delay time	SPISCLK falling edge to SPISMISO output delay time	-	-	30	ns

Table 21. SPI-bus slave timing

Symbol	Parameter	Conditions	Min	Typ	Max	Unit
$t_{d(S-Q)}$	chip select to data output delay time	SPISSEL falling edge to SPISMISO output delay time	-	-	30	ns
$t_{su(S)}$	chip select set-up time	SPISSEL falling edge to SPISCLK rising edge delay time	30	-	-	ns
$t_{h(S)}$	chip select hold time	SPISCLK falling edge to SPISSEL rising edge delay time	30	-	-	ns

14.3.4 2-wire serial interface

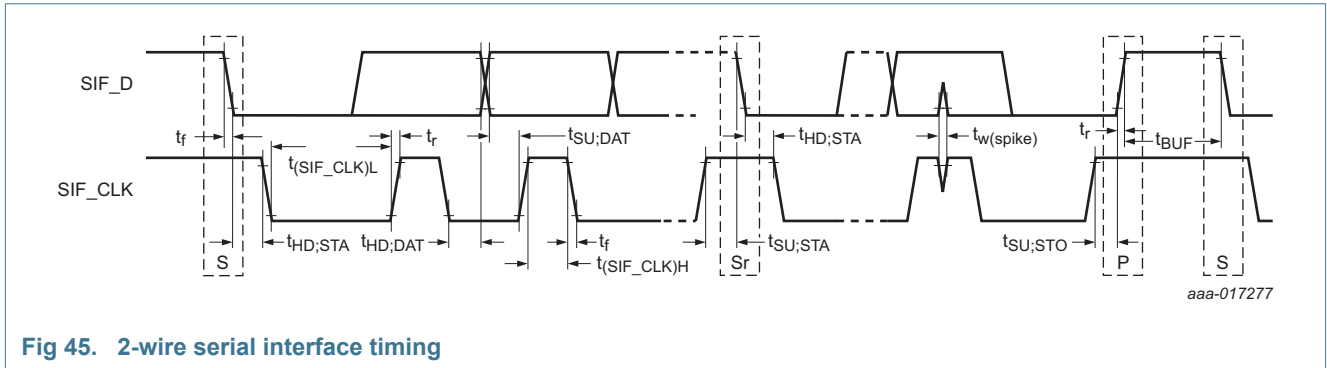

Fig 45. 2-wire serial interface timing

Table 22. 2-wire serial interface

Symbol	Parameter	Conditions	Standard mode		Fast mode		Unit
			Min	Max	Min	Max	
f_{clk}	clock frequency	SIF_CLK; DIO14; pin 38	0	100	0	400	kHz
$t_{HD,STA}$	hold time (repeated) START condition	[1]	4	-	0.6	-	μs
$t_{(SIF_CLK)L}$	LOW period of the SIF_CLK clock		4.7	-	1.3	-	μs
$t_{(SIF_CLK)H}$	HIGH period of the SIF_CLK clock		4	-	0.6	-	μs
$t_{SU,STA}$	set-up time for a repeated START condition		4.7	-	0.6	-	μs
$t_{SU,DAT}$	data set-up time	data setup time SIF_D	0.25	-	0.1	-	μs
$t_{HD,DAT}$	data hold time	data hold time SIF_D	0[2]	-	0[2]	-	μs
t_r	rise time	rise time SIF_D and SIF_CLK	-	1000	$20 + 0.1C_b$	300	ns
t_f	fall time	fall time SIF_D and SIF_CLK	-	300	$20 + 0.1C_b$	300	ns
$t_{SU,STO}$	set-up time for STOP condition		4	-	0.6	-	μs
t_{BUF}	bus free time between a STOP and START condition		4.7	-	1.3	-	μs
$t_w(spikes)$	spike pulse width	pulse width of spikes that will be suppressed by input filters	[1]	60	-	60	ns

Table 22. 2-wire serial interface

Symbol	Parameter	Conditions	Standard mode		Fast mode		Unit
			Min	Max	Min	Max	
C_b	capacitive load for each bus line		-	400	-	400	pF
V_{nL}	noise margin at the LOW level	noise margin at the LOW level for each connected device (including hysteresis)	$0.1V_{DD}$	-	$0.1V_{DD}$	-	V
V_{nH}	noise margin at the HIGH level	noise margin at the HIGH level for each connected device (including hysteresis)	$0.2V_{DD}$	-	$0.2V_{DD}$	-	V

[1] After this period, the first clock pulse is generated.

[2] A device must internally provide a hold time of at least 300 ns for the SIF_D signal (with respect to the $V_{IH(min)}$ of the SIF_CLK signal) to bridge the undefined region of the falling edge of SIF_CLK.

14.3.5 Wake-up timings

Table 23. Wake-up timings

Symbol	Parameter	Conditions	Min	Typ	Max	Unit
$t_{startup}$	start-up time	CPU start-up time; time for crystal to stabilize ready to run CPU; reached oscillator amplitude threshold. Default bias current	-	0.74	-	ms
		radio start-up time; time for crystal to stabilize ready for radio activity	-	1	-	ms
		from reset RESET_N pin, BOR or SVM	-	180	-	μ s
t_{wake}	wake-up time	from deep sleep mode or from sleep mode	-	170	-	μ s
t_{wake}	wake-up time	from CPU Doze mode	-	0.2	-	μ s

14.3.6 Band gap reference

Table 24. Band gap reference

$V_{DD} = 2 V$ to $3.6 V$; unless otherwise specified.

Symbol	Parameter	Conditions	Min	Typ	Max	Unit
$V_{DDA(bg)}$	band gap analog supply voltage		1.198	1.235	1.260	V

14.3.7 Analog to Digital Converters

Table 25. Analog to Digital Converters

$V_{DD} = 3 V$; $V_{ref} = 1.2 V$; $T_{amb} = -40\text{ }^{\circ}\text{C}$ to $+125\text{ }^{\circ}\text{C}$; unless otherwise specified.

Symbol	Parameter	Conditions	Min	Typ	Max	Unit
V_i	input voltage	switchable [1]	0.04	-	$2V_{ref}$	V
V_{ref}	reference voltage	internal [2]	-	-	-	V
		external; allowable range into VREF pin	-	1.2	-	V
I_{ADCx}	current on pins ADCx [3]		-	400	-	μ A
INL	integral non-linearity	$T_{amb} = -40\text{ }^{\circ}\text{C}$ to $+85\text{ }^{\circ}\text{C}$	-	± 1.6	-	LSB
		$T_{amb} = -40\text{ }^{\circ}\text{C}$ to $+125\text{ }^{\circ}\text{C}$	-	± 1.8	-	LSB
DNL	differential non-linearity	guaranteed monotonic [4]	-	± 0.5	-	LSB

Table 25. Analog to Digital Converters ...continued $V_{DD} = 3\text{ V}$; $V_{ref} = 1.2\text{ V}$; $T_{amb} = -40\text{ }^{\circ}\text{C}$ to $+125\text{ }^{\circ}\text{C}$; unless otherwise specified.

Symbol	Parameter	Conditions	Min	Typ	Max	Unit
E_O	offset error	0 to V_{ref} range	-	-10	-	mV
		0 to $2 \times V_{ref}$ range	-	-20	-	mV
E_G	gain error	0 to V_{ref} range	-	-10	-	mV
		0 to $2 \times V_{ref}$ range	-	-20	-	mV
$f_{clk(int)}$	internal clock frequency	16 MHz input clock [5]				
		$\div 16$	-	1	-	MHz
		$\div 32$	-	0.5	-	MHz
		$\div 64$	-	0.25	-	MHz
t_{conv}	conversion time	programmable	9.5	-	148	μs
$C_{i(a)}$	analog input capacitance	in series with 5 k Ω resistor	-	8	-	pF

[1] See Section 9.15.1.1.

[2] See Section 14.3.6.

[3] With $x = 1, 2, 3, 4, 5$ or 6 .

[4] Guaranteed monotonic.

[5] Number of internal clock periods to sample input (programmable at 2, 4, 6 or 8).

14.3.8 Comparator

Table 26. Comparator $V_{DD} = 2\text{ V}$ to 3.6 V ; $T_{amb} = -40\text{ }^{\circ}\text{C}$ to $+125\text{ }^{\circ}\text{C}$; unless otherwise specified.

Symbol	Parameter	Conditions	Min	Typ	Max	Unit
t_{resp}	response time	operating mode [1]	-	90	-	ns
		low-power mode [2]	-	2.2	-	ns
$t_{res(tot)}$	total response time	operating mode; including delay to interrupt controller [3]	-	130	-	ns
V_{hys}	hysteresis voltage	programmable in 3 steps	-	10	-	mV
			-	20	-	mV
			-	40	-	mV
V_{ref}	reference voltage	[4]	-	-	-	V
$V_{I(cm)}$	common-mode input voltage		0	-	V_{DD}	V
I_I	input current	operating mode	-	73	-	μA
		low-power mode	-	0.8	-	μA

[1] $\pm 250\text{ mV}$ overdrive; 10 pF load.[2] $\pm 250\text{ mV}$ overdrive; no digital delay.

[3] Digital delay can be up to a maximum of two 16 MHz clock periods.

[4] See Section 14.3.6.

14.3.9 32 kHz RC oscillator

Table 27. 32 kHz RC oscillator

$V_{DD} = 2\text{ V to }3.6\text{ V}$; $T_{amb} = -40^{\circ}\text{C to }+125^{\circ}\text{C}$; unless otherwise specified.

Symbol	Parameter	Conditions	Min	Typ	Max	Unit
Δf_{xtal}	crystal frequency accuracy	32 kHz clock uncalibrated accuracy; without temperature and voltage variation [1]	32 – 21%	32	32 + 53%	kHz
		calibration done in operating mode; calibrated 32 kHz accuracy; for a 1 s sleep period calibrating over 20 x 32 kHz clocks periods	-	±300	-	ppm
		calibration done in low-power mode; calibrated 32 kHz accuracy; for a 1 s sleep period calibrating over 20 x 32 kHz clocks periods	-	±600	-	ppm

[1] Measured at 3 V and 25 °C.

14.3.10 32 kHz crystal oscillator

Table 28. 32 kHz crystal oscillator

$V_{DD} = 2\text{ V to }3.6\text{ V}$; $T_{amb} = -40^{\circ}\text{C to }+125^{\circ}\text{C}$; unless otherwise specified.

Symbol	Parameter	Conditions	Min	Typ	Max	Unit
$I_{DD(\text{xtal})}$	crystal oscillator supply current	of cell and counter-logic [1]	-	0.6	-	μA
t_{startup}	start-up time	[2]	-	0.6	-	s

[1] This is sensitive to the ESR of the crystal, V_{DD} and total capacitance at each pin.

[2] Assuming crystal with ESR of less than 40 Ω, $C_L = 9\text{ pF}$ and external capacitances = 15 pF ($V_{DD} / 2\text{ mV(p-p)}$).

When external 32 kHz oscillator is used, external capacitances of 15 pF are implemented. Total external capacitance needs to be $2 \times C_L$, allowing for stray capacitance from chip, package and PCB ($C_L = 9\text{ pF}$).

14.3.11 32 MHz crystal oscillator

Table 29. 32 MHz crystal oscillator

$V_{DD} = 2\text{ V to }3.6\text{ V}$; $T_{amb} = -40^{\circ}\text{C to }+125^{\circ}\text{C}$; unless otherwise specified.

Symbol	Parameter	Conditions	Min	Typ	Max	Unit
$I_{DD(\text{xtal})}$	crystal oscillator supply current	of cell and counter-logic [1]	-	275	-	μA
t_{startup}	start-up time	[2]	-	0.74	-	ms

[1] Excluding band gap ref.

[2] Assuming crystal with ESR of less than 40 Ω, $C_L = 9\text{ pF}$ and external capacitances = 15 pF ($V_{DD} / 2\text{ mV(p-p)}$).

When external 32 MHz oscillator is used, external capacitances of 12 pF are implemented. Total external capacitance needs to be $2 \times C_L$, allowing for stray capacitance from chip, package and PCB ($C_L = 9\text{ pF}$).

14.3.12 High-speed RC oscillator

Table 30. High-speed RC oscillator

$V_{DD} = 2\text{ V to }3.6\text{ V}$; $T_{amb} = -40^{\circ}\text{C to }+125^{\circ}\text{C}$; unless otherwise specified.

Symbol	Parameter	Conditions	Min	Typ	Max	Unit
$I_{DD(xtal)}$	crystal oscillator supply current	of cell	-	145	-	μA
f_{osc}	oscillator frequency	uncalibrated	26.1 – 16%	26.1	26.1 + 18%	MHz
		calibrated	32.1 – 4%	32.1	32.1 + 5%	MHz
$t_{startup}$	start-up time		-	2.4	-	μs

14.3.13 Temperature sensor

Table 31. Temperature sensor

$V_{DD} = 2\text{ V to }3.6\text{ V}$; $T_{amb} = -40^{\circ}\text{C to }+125^{\circ}\text{C}$; unless otherwise specified.

Symbol	Parameter	Conditions	Min	Typ	Max	Unit
T_{sen}	sensor temperature		-40	-	+125	$^{\circ}\text{C}$
G_{sen}	sensor gain		-	-1.66	-	$\text{mV}/^{\circ}\text{C}$
ΔT_{sen}	sensor temperature accuracy		-	± 7	-	$^{\circ}\text{C}$
V_o	output voltage		[1] 540	-	840	mV
V_{sen}	sensor voltage	at $V_{DD} = 3.0\text{ V}$ and $T_{amb} = 25^{\circ}\text{C}$	-	720	-	mV

[1] Includes absolute variation due to manufacturing and temperature.

14.3.14 Non-volatile memory

Table 32. Non-volatile memory

$V_{DD} = 2\text{ V to }3.6\text{ V}$; $T_{amb} = -40^{\circ}\text{C to }+125^{\circ}\text{C}$; unless otherwise specified.

Symbol	Parameter	Conditions	Min	Typ	Max	Unit
N_{endu}	endurance	Flash; program/erase	[1] 10	50	-	kCycle
		EEPROM; program/erase	[2] 100	500	-	kCycle
t_{er}	erase time	Flash; one sector	-	100	-	ms
t_{prog}	programming time	Flash; per page of 256 bytes	-	1.0	-	ms
t_{er}	erase time	EEPROM; one 64-byte page	-	1.8	-	ms
t_{prog}	programming time	EEPROM; between 1 byte and 64 bytes	-	1.1	-	ms
t_{ret}	retention time	powered; Flash and EEPROM	10	-	-	year

[1] See [Section 9.2.1](#).

[2] See [Section 9.2.4](#).

14.3.15 Radio transceiver

This JN5169 meets all the requirements of the IEEE802.15.4 standard over 2.0 V to 3.6 V and offers the improved RF characteristics shown in [Table 33](#). All RF characteristics are measured single ended.

This part also meets the following regulatory body approvals, when used with NXP's Module Reference Designs. Compliant with *FCC part 15 rules*, *IC Canada* and *ETSI ETS 300-328*, refer to the JN5169 Module Reference Design package on the Wireless Connectivity area of the NXP web site [Ref. 1](#).

The PCB schematic and layout rules detailed in [Section 15](#) must be followed. Failure to do so will likely result in the JN5169 failing to meet the performance specification detailed herein and worst case may result in device not functioning in the end application.

Table 33. RF port characteristics

Single-ended; Impedance = 50 Ω^[1]; V_{DD} = 2 V to 3.6 V; T_{amb} = -40°C to +125°C; unless otherwise specified.

Symbol	Parameter	Conditions	Min	Typ	Max	Unit
f _{range}	frequency range		2.4		2.485	GHz
V _{ESD}	electrostatic discharge voltage	pin 13				
		HBM	-	2	-	kV
		CDM	-	1000	-	V

[1] With external matching inductors and assuming PCB layout as in [Section 15.1.1](#).

Table 34. Radio transceiver characteristics: +25 °C

V_{DD} = 2 V to 3.6 V; unless otherwise specified.

Symbol	Parameter	Conditions	Min	Typ	Max	Unit	
Receiver							
S _{RX}	receiver sensitivity	nominal for 1 % PER, as per 802.15.4	-	-96	-93.5	dBm	
P _{I(RX)(max)}	maximum receiver input power	1 % PER, measured as sensitivity; supply current at 14.7 mA; high-performance mode	-	10	-	dBm	
		1 % PER, measured as sensitivity; supply current at 13 mA; low-power mode	-	0	-	dBm	
α _{ch}	channel rejection	1 % PER, with wanted signal 3 dB, above sensitivity as per 802.15.4 modulated interferer ^{[1][2]}					
		-1 channel	-	19	-	dBc	
		+1 channel	-	34	-	dBc	
		-2 channel	-	40	-	dBc	
		+2 channel	-	44	-	dBc	
		co-channel	-	-7	-	dBc	
		CW interferer ^{[1][2]}					
		-1 channel	-	25	-	dBc	
		+1 channel	-	50	-	dBc	
		-2 channel	-	57	-	dBc	
+2 channel	-	60	-	dBc			
α _{ib}	in-band rejection	1 % PER with wanted signal 3 dB above sensitivity; 2.4 GHz to 2.4835 GHz; modulated interferers at 3 channel separation ^[1]	-	48	-	dBc	
α _{oob}	out-of-band rejection	1 % PER with wanted signal 3 dB above sensitivity ^[1]					
		all frequencies except wanted/2 which is 8 dB lower	-	45	-	dBc	
		3G frequency at 2.1 GHz	-	-5	-	dBm	
		LTE frequency at 2.5 GHz	-	-18	-	dBm	

Table 34. Radio transceiver characteristics: +25 °C ...continued

$V_{DD} = 2\text{ V to }3.6\text{ V}$; unless otherwise specified.

Symbol	Parameter	Conditions	Min	Typ	Max	Unit
P _{sp(RX)}	receiver spurious power	measured conducted into 50 Ω				
		30 MHz to 1 GHz	-	-	-70	dBm
		1 GHz to 12 GHz	-	-	-70	dBm
P _{L(lo)}	local oscillator leakage power		-	-	-58	dBm
IMP	intermodulation protection	1 % PER at with wanted signal 3 dB above sensitivity; modulated interferers at 3 and 6 channel separation [1]	-	46	-	dB
Δα _{RSSI}	RSSI variation	-95 dBm to -10 dBm; available through JN5169 Integrated Peripherals API	-4	-	+4	dB
Transmitter						
P _o	output power	[3]	-	10	-	dBm
P _{o(cr)}	control range output power	in 6 major steps and then 4 fine steps [4]	-	-42	-	dB
P _{sp(TX)}	transmitter spurious power	measured conducted into 50 Ω				
		30 MHz to 1 GHz	-	-	-65	dBm
		1 GHz to 12.5 GHz (harmonic 2)	-	-	-36	dBm
		exceptions				
		1.8 GHz to 1.9 GHz	-	-	-65	dBm
		5.15 GHz to 5.3 GHz	-	-	-65	dBm
EVM	error vector magnitude	at maximum output power	-	8	-	%
EVM _{offset}	error vector magnitude offset	at maximum output power	-	3	4.5	%
PSD	power spectral density	relative density at greater than 3.5 MHz offset [5]	-	-38	-20	dBc
		absolute density at greater than 3.5 MHz offset [5]	-	-32	-	dBm

[1] Blocker rejection is defined as the value, when 1 % PER is seen with the wanted signal 3 dB above sensitivity, as per IEEE802.15.4.

[2] Channels 11, 17, 24 low/high values reversed.

[3] To reach the maximum TX power, 2.8 V is the minimum on V_{DDA}.

[4] Up to an extra 2.5 dB of attenuation is available if required.

[5] See IEEE802.15.4.

Table 35. Radio transceiver characteristics: -40 °C

$V_{DD} = 2\text{ V to }3.6\text{ V}$; unless otherwise specified.

Symbol	Parameter	Conditions	Min	Typ	Max	Unit
Receiver						
S _{RX}	receiver sensitivity	nominal for 1 % PER, as per 802.15.4	-	-96.5	-	dBm
P _{I(RX)(max)}	maximum receiver input power	1 % PER, measured as sensitivity; supply current at 14.7 mA; high-performance mode	-	10	-	dBm
		1 % PER, measured as sensitivity; supply current at 13 mA; low-power mode	-	0	-	dBm

Table 35. Radio transceiver characteristics: –40 °C ...continued

$V_{DD} = 2\text{ V to }3.6\text{ V}$; unless otherwise specified.

Symbol	Parameter	Conditions	Min	Typ	Max	Unit
α_{ch}	channel rejection	1 % PER, with wanted signal 3 dB, above sensitivity as per 802.15.4 modulated interferer ^{[1][2]}				
		–1 channel	-	19	-	dBc
		+1 channel	-	34	-	dBc
		–2 channel	-	40	-	dBc
		+2 channel	-	44	-	dBc
		co-channel	-	–7	-	dBc
α_{ib}	in-band rejection	1 % PER with wanted signal 3 dB above sensitivity; 2.4 GHz to 2.4835 GHz; modulated interferers at 3 channel separation ^[1]	-	48	-	dBc
α_{oob}	out-of-band rejection	1 % PER with wanted signal 3 dB above sensitivity; all frequencies except wanted/2 which is 8 dB lower ^[1]	-	45	-	dBc
$P_{sp(RX)}$	receiver spurious power	measured conducted into 50 Ω				
		30 MHz to 1 GHz	-	-	–70	dBm
		1 GHz to 12 GHz	-	-	–70	dBm
$P_{L(lo)}$	local oscillator leakage power		-	-	–58	dBm
IMP	intermodulation protection	1 % PER at with wanted signal 3 dB above sensitivity; modulated interferers at 3 and 6 channel separation ^[1]	-	45	-	dB
$\Delta\alpha_{RSSI}$	RSSI variation	–95 dBm to –10 dBm; available through JN5169 Integrated Peripherals API	-	±4	-	dB
Transmitter						
P_o	output power		-	10	-	dBm
$P_{o(cr)}$	control range output power	in 6 major steps and then 4 fine steps ^[4]	-	–42	-	dB
$P_{sp(TX)}$	transmitter spurious power	measured conducted into 50 Ω				
		30 MHz to 1 GHz	-	-	–65	dBm
		1 GHz to 12.5 GHz (harmonic 2)	-	-	–36	dBm
		exceptions				
		1.8 GHz to 1.9 GHz	-	-	–65	dBm
	5.15 GHz to 5.3 GHz	-	-	–65	dBm	
EVM	error vector magnitude	at maximum output power	-	8	-	%
EVM_{offset}	error vector magnitude offset	at maximum output power	-	3	-	%
PSD	power spectral density	relative density at greater than 3.5 MHz offset ^[5]	-	–38	-	dBc
		absolute density at greater than 3.5 MHz offset ^[5]	-	–32	-	dBm

[1] Blocker rejection is defined as the value, when 1 % PER is seen with the wanted signal 3 dB above sensitivity, as per IEEE802.15.4.

[2] Channels 11, 17, 24 low/high values reversed.

- [3] To reach the maximum TX power, 2.8 V is the minimum on V_{DDA} .
 [4] Up to an extra 2.5 dB of attenuation is available if required.
 [5] See IEEE802.15.4.

Table 36. Radio transceiver characteristics: +125 °C
 $V_{DD} = 2 V$ to $3.6 V$; unless otherwise specified.

Symbol	Parameter	Conditions	Min	Typ	Max	Unit
Receiver						
S_{RX}	receiver sensitivity	nominal for 1 % PER, as per 802.15.4	-	-94	-	dBm
$P_{i(RX)(max)}$	maximum receiver input power	1 % PER, measured as sensitivity; supply current at 14.7 mA; high-performance mode	-	5	-	dBm
		1 % PER, measured as sensitivity; supply current at 13 mA; low-power mode	-	0	-	dBm
α_{ch}	channel rejection	1 % PER, with wanted signal 3 dB, above sensitivity as per 802.15.4 modulated interferer ^{[1][2]}				
		-1 channel	-	18	-	dBc
		+1 channel	-	31	-	dBc
		-2 channel	-	38	-	dBc
		+2 channel	-	42	-	dBc
		co-channel	-	-7	-	dBc
α_{ib}	in-band rejection	1 % PER with wanted signal 3 dB above sensitivity; 2.4 GHz to 2.4835 GHz; modulated interferers at 3 channel separation ^[1]	-	46	-	dBc
α_{oob}	out-of-band rejection	1 % PER with wanted signal 3 dB above sensitivity; all frequencies except wanted/2 which is 8 dB lower ^[1]	-	42	-	dBc
$P_{sp(RX)}$	receiver spurious power	measured conducted into 50 Ω				
		30 MHz to 1 GHz	-	-	-70	dBm
		1 GHz to 12 GHz	-	-	-70	dBm
$P_{L(lo)}$	local oscillator leakage power		-	-	-58	dBm
IMP	intermodulation protection	1 % PER at with wanted signal 3 dB above sensitivity; modulated interferers at 3 and 6 channel separation ^[1]	-	45	-	dB
$\Delta\alpha_{RSSI}$	RSSI variation	-95 dBm to -10 dBm; available through JN5169 Integrated Peripherals API	-	± 4	-	dB
Transmitter						
P_o	output power		^[3]	10	-	dBm
$P_{o(cr)}$	control range output power	in 6 major steps and then 4 fine steps ^[4]	-	-42	-	dB
$P_{sp(TX)}$	transmitter spurious power	measured conducted into 50 Ω				
		30 MHz to 1 GHz	-	-	-65	dBm
		1 GHz to 12.5 GHz (harmonic 2)	-	-	-36	dBm
		exceptions				
		1.8 GHz to 1.9 GHz	-	-	-65	dBm
	5.15 GHz to 5.3 GHz	-	-	-65	dBm	

Table 36. Radio transceiver characteristics: +125 °C ...continued

$V_{DD} = 2\text{ V to }3.6\text{ V}$; unless otherwise specified.

Symbol	Parameter	Conditions	Min	Typ	Max	Unit
EVM	error vector magnitude	at maximum output power	-	8	-	%
EVM_{offset}	error vector magnitude offset	at maximum output power	-	3	-	%
PSD	power spectral density	relative density at greater than 3.5 MHz offset [5]	-	-38	-	dBc
		absolute density at greater than 3.5 MHz offset [5]	-	-32	-	dBm

- [1] Blocker rejection is defined as the value, when 1 % PER is seen with the wanted signal 3 dB above sensitivity, as per IEE802.15.4.
- [2] Channels 11, 17, 24 low/high values reversed.
- [3] To reach the maximum TX power, 2.8 V is the minimum on V_{DDA} .
- [4] Up to an extra 2.5 dB of attenuation is available if required.
- [5] See IEEE802.15.4.

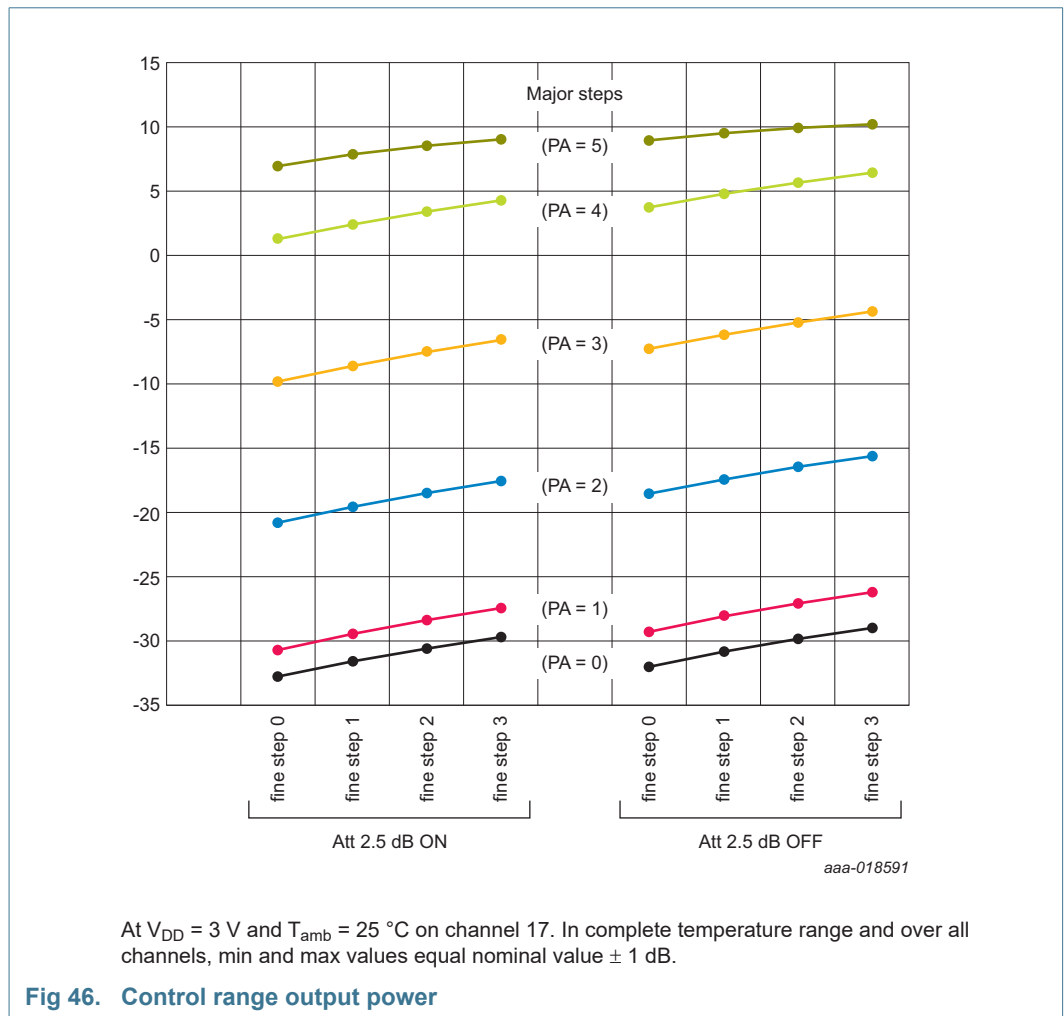

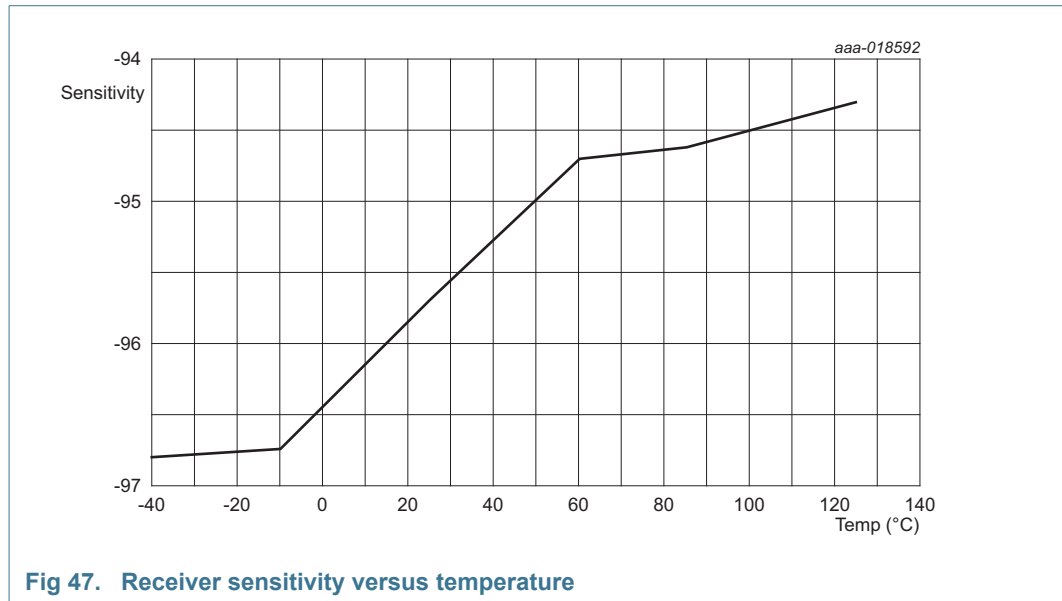

15. Application information

15.1 JN5169 module reference designs

For customers wishing to integrate the JN5169 device directly into their system, NXP provides a range of Module Reference Designs.

To ensure the correct performance, it is strongly recommended that where possible the design details provided by the reference designs are used in their exact form for all end designs; this includes component values, pad dimensions, track layouts etc. In order to minimize all risks, it is recommended that the entire layout of the appropriate reference module, if possible, be replicated in the end design.

For full details, see the Wireless Connectivity area of the NXP web site [Ref. 1](#); Contact technical support.

15.1.1 Schematic diagram

A schematic diagram of the JN5169 reference module is shown in [Figure 48](#). Details of component values and PCB layout constraints can be found in [Table 37](#).

The paddle should be connected directly to ground. Any pads that require connection to ground should do so by connecting directly to the paddle.

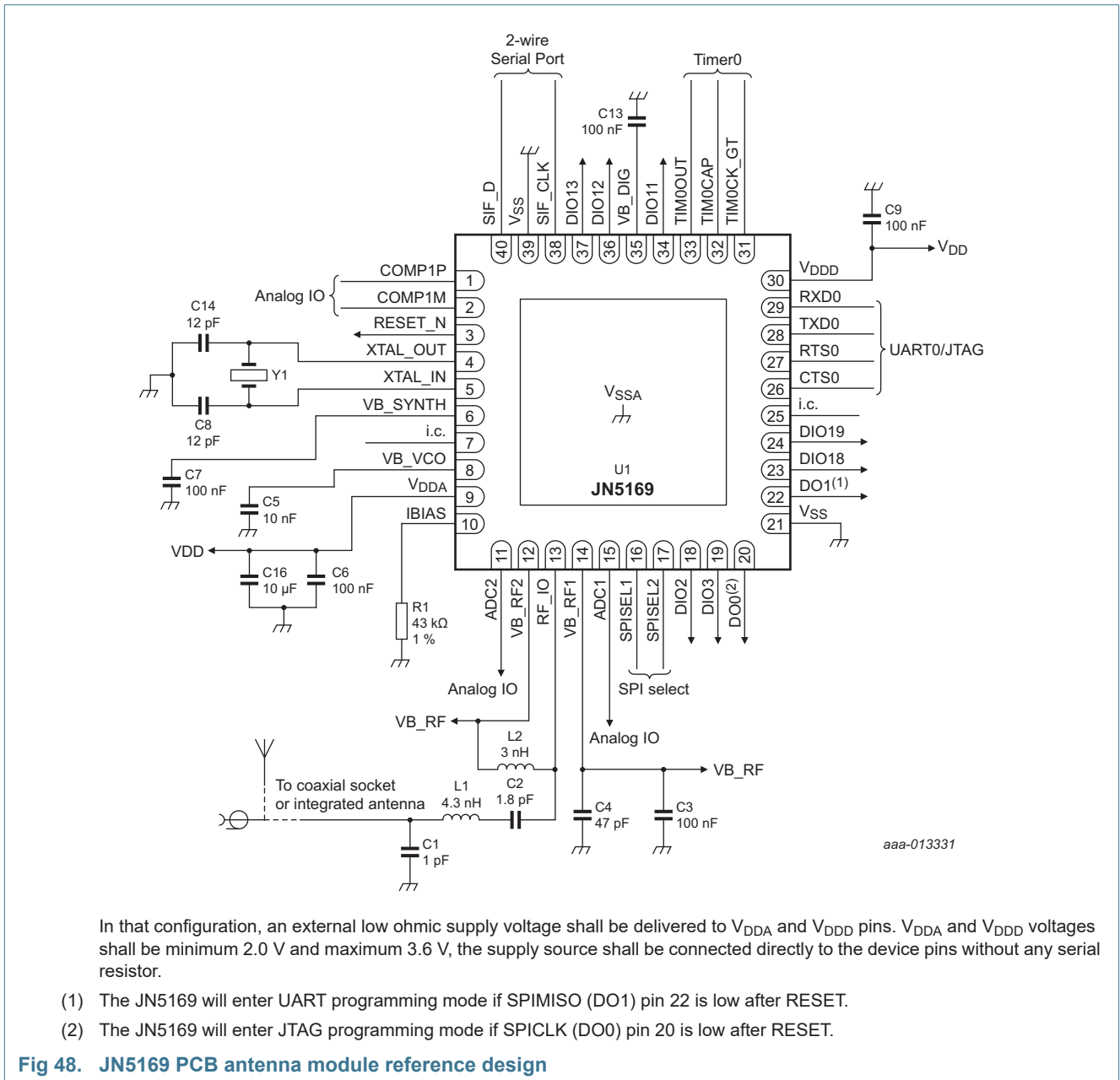

Table 37. Components

Component	Function	Value	Remarks
C1	RF matching capacitor	1 pF	[1] COG type
C2	AC coupling	1.8 pF	[1] COG type
C3	VB RF decoupling	100 nF	locate less than 5 mm from U1 pin 12 and U1 pin 14
C4	VB RF decoupling	47 pF	locate less than 5 mm from U1 pin 12 and U1 pin 14
C5	VB VCO decoupling	10 nF	locate less than 5 mm from U1 pin 8
C6	analog power decoupling	100 nF	locate less than 5 mm from U1 pin 9
C7	VB synt decoupling	100 nF	locate less than 5 mm from U1 pin 6

Table 37. Components ...continued

Component	Function	Value	Remarks
C8	crystal load capacitance	12 pF ± 5 % C0G	adjacent to U1 pin 5 and Y1 pin 3
C9	digital power decoupling	100 nF	adjacent to U1 pin 30
C13	VB Dig decoupling	100 nF	locate less than 5 mm from U1 pin 35
C14	crystal load capacitance	12 pF ± 5 % C0G	adjacent to U1 pin 4 and Y1 pin 1
C16	power source decoupling	10 μF	
L1	RF matching inductor	4.3 nH	[1] MuRata LQP15MN4N3B02 can be used up to 85 °C; MuRata LQG15MN4N3B02 can be used up to 125 °C
L2	load inductor	3 nH	[1] MuRata LQP15MN3N0B02 can be used up to 85 °C; MuRata LQG15MN3N0B02 can be used up to 125 °C
R1	IBIAS resistor	43 kΩ 1%	
Y1	crystal	32 MHz; C _L = 9 pF	AEL X32M000000S039 or NDK NX3225SA EXS00A-CS08207 or NX2016SA 32 MHz EXS00A-CS07977 or MuRata XR16GD32M000KYQ01R0 (2016) or Epson Toyocom X1E000021016700

[1] Must be copied directly from the reference design.

15.1.2 Application diagram with Pi filter

Extra pi filter is recommended on RF path to insure a successful FCC certification regarding H2 spurs. This is the implemented solution for the NXP modules available on the market.

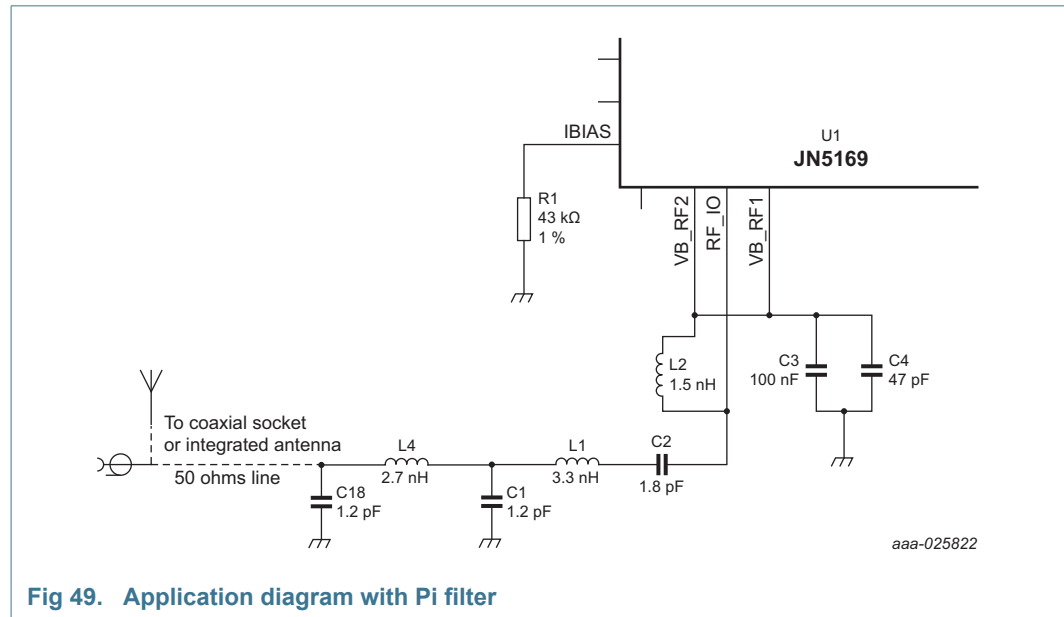

Fig 49. Application diagram with Pi filter

Table 38. Components

Component	Function	Value		Remarks
C1	RF matching capacitor	1.2 pF	[1]	COG type
C2	AC coupling	1.8 pF	[1]	COG type
C3	VB RF decoupling	100 nF		locate less than 5 mm from U1 pin 12 and U1 pin 14
C4	VB RF decoupling	47 pF		locate less than 5 mm from U1 pin 12 and U1 pin 14
C18	RF filtering capacitor	1.2 pF		COG type
L1	RF matching inductor	3.3 nH	[1]	MuRata LQP15MN3N3B02 can be used up to 85 °C; MuRata LQG15MN3N3B02 can be used up to 125 °C
L2	load inductor	1.5 nH	[1]	MuRata LQP15MN1N5B02 can be used up to 85 °C; MuRata LQG15MN1N5B02 can be used up to 125 °C
L4	filtering inductor	2.7 nH	[1]	MuRata LQP15MN2N7B02 can be used up to 85 °C; MuRata LQG15MN2N7B02 can be used up to 125 °C
R1	IBIAS resistor	43 kΩ 1%		

[1] Must be copied directly from the reference design.

15.1.3 PCB design and reflow profile

PCB and land pattern designs are key to the reliability of any electronic circuit design.

The Institute for Interconnecting and Packaging Electronic Circuits (IPC) defines a number of standards for electronic devices. One of these is the "Surface Mount Design and Land Pattern Standard" IPC-SM-782 commonly referred to as "IPC782". This specification defines the physical packaging characteristics and land patterns for a range of surface-mounted devices. IPC782 is also a useful reference document for general surface mount design techniques, containing sections on design requirements, reliability and testability. NXP strongly recommends that this be referred to when designing the PCB.

NXP also provides an Application Note *AN10366, "HVQFN application information"*, (see the Wireless Connectivity area of the NXP web site [Ref. 1](#)), which describes the reflow soldering process. The suggested reflow profile from this Application Note is shown in [Figure 50](#). The specific paste manufacturers guidelines on peak flow temperature, soak times, time above liquids and ramp rates should also be referenced.

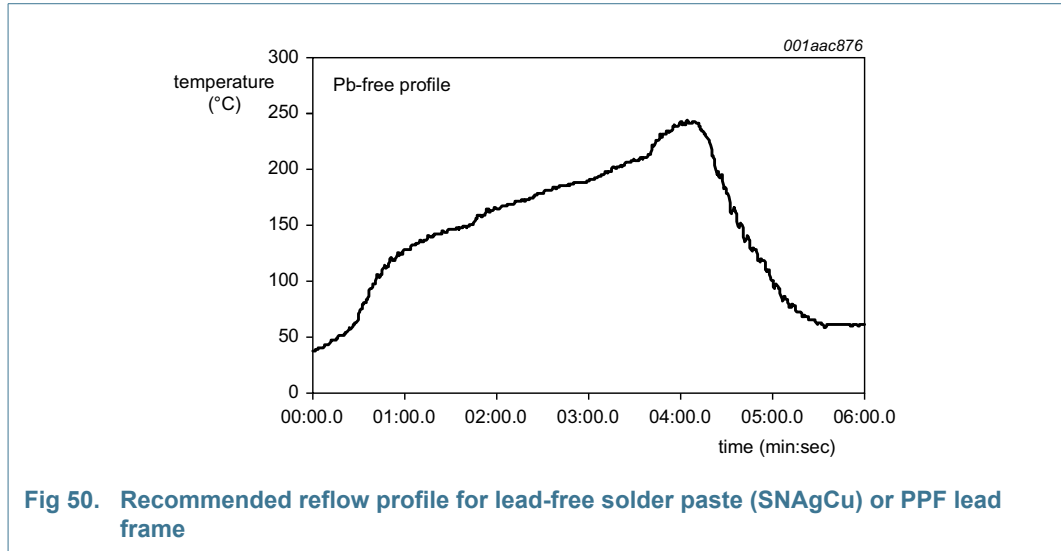

15.1.4 Moisture sensitivity level (MSL)

If there is moisture trapped inside a package and the package is exposed to a reflow temperature profile, the moisture may turn into steam, which expands rapidly. This may cause damage to the inside of the package (delamination) and may result in a cracked semiconductor package body (the popcorn effect). A package’s MSL depends on the package characteristics and on the temperature to which it is exposed to during reflow soldering. This is explained in more detail in the Wireless Connectivity area of the NXP web site [Ref. 1](#)).

Depending on the damage after this test, an MSL of 1 (not sensitive to moisture) to 6 (very sensitive to moisture) is attached to the semiconductor package.

16. Footprint information for reflow soldering

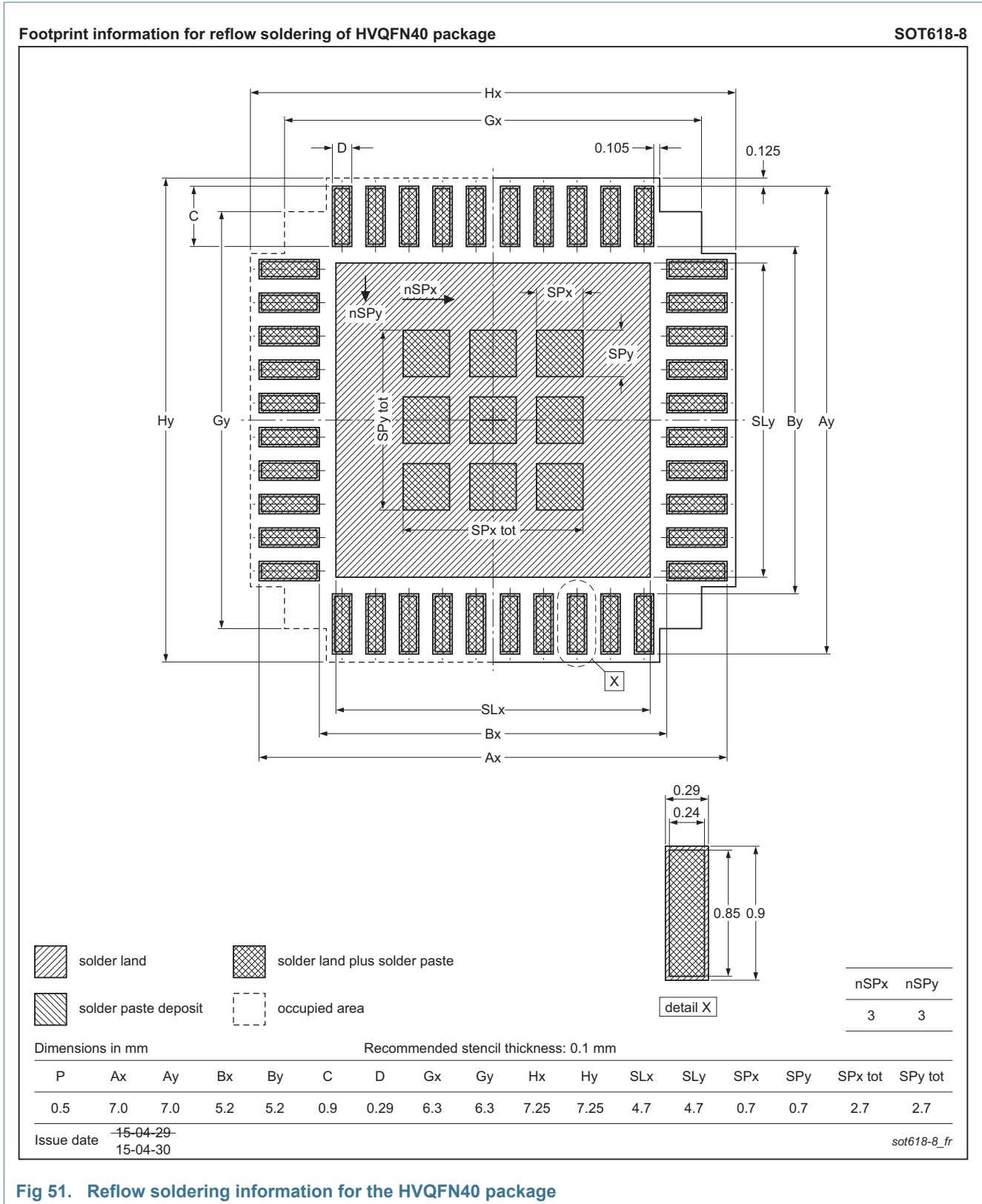

Fig 51. Reflow soldering information for the HVQFN40 package

18. Soldering of SMD packages

This text provides a very brief insight into a complex technology. A more in-depth account of soldering ICs can be found in Application Note *AN10365 “Surface mount reflow soldering description”*.

18.1 Introduction to soldering

Soldering is one of the most common methods through which packages are attached to Printed Circuit Boards (PCBs), to form electrical circuits. The soldered joint provides both the mechanical and the electrical connection. There is no single soldering method that is ideal for all IC packages. Wave soldering is often preferred when through-hole and Surface Mount Devices (SMDs) are mixed on one printed wiring board; however, it is not suitable for fine pitch SMDs. Reflow soldering is ideal for the small pitches and high densities that come with increased miniaturization.

18.2 Wave and reflow soldering

Wave soldering is a joining technology in which the joints are made by solder coming from a standing wave of liquid solder. The wave soldering process is suitable for the following:

- Through-hole components
- Leaded or leadless SMDs, which are glued to the surface of the printed circuit board

Not all SMDs can be wave soldered. Packages with solder balls, and some leadless packages which have solder lands underneath the body, cannot be wave soldered. Also, leaded SMDs with leads having a pitch smaller than ~0.6 mm cannot be wave soldered, due to an increased probability of bridging.

The reflow soldering process involves applying solder paste to a board, followed by component placement and exposure to a temperature profile. Leaded packages, packages with solder balls, and leadless packages are all reflow solderable.

Key characteristics in both wave and reflow soldering are:

- Board specifications, including the board finish, solder masks and vias
- Package footprints, including solder thieves and orientation
- The moisture sensitivity level of the packages
- Package placement
- Inspection and repair
- Lead-free soldering versus SnPb soldering

18.3 Wave soldering

Key characteristics in wave soldering are:

- Process issues, such as application of adhesive and flux, clinching of leads, board transport, the solder wave parameters, and the time during which components are exposed to the wave
- Solder bath specifications, including temperature and impurities

18.4 Reflow soldering

Key characteristics in reflow soldering are:

- Lead-free versus SnPb soldering; note that a lead-free reflow process usually leads to higher minimum peak temperatures (see [Figure 53](#)) than a SnPb process, thus reducing the process window
- Solder paste printing issues including smearing, release, and adjusting the process window for a mix of large and small components on one board
- Reflow temperature profile; this profile includes preheat, reflow (in which the board is heated to the peak temperature) and cooling down. It is imperative that the peak temperature is high enough for the solder to make reliable solder joints (a solder paste characteristic). In addition, the peak temperature must be low enough that the packages and/or boards are not damaged. The peak temperature of the package depends on package thickness and volume and is classified in accordance with [Table 39](#) and [40](#)

Table 39. SnPb eutectic process (from J-STD-020C)

Package thickness (mm)	Package reflow temperature (°C)	
	Volume (mm ³)	
	< 350	≥ 350
< 2.5	235	220
≥ 2.5	220	220

Table 40. Lead-free process (from J-STD-020C)

Package thickness (mm)	Package reflow temperature (°C)		
	Volume (mm ³)		
	< 350	350 to 2000	> 2000
< 1.6	260	260	260
1.6 to 2.5	260	250	245
> 2.5	250	245	245

Moisture sensitivity precautions, as indicated on the packing, must be respected at all times.

Studies have shown that small packages reach higher temperatures during reflow soldering, see [Figure 53](#).

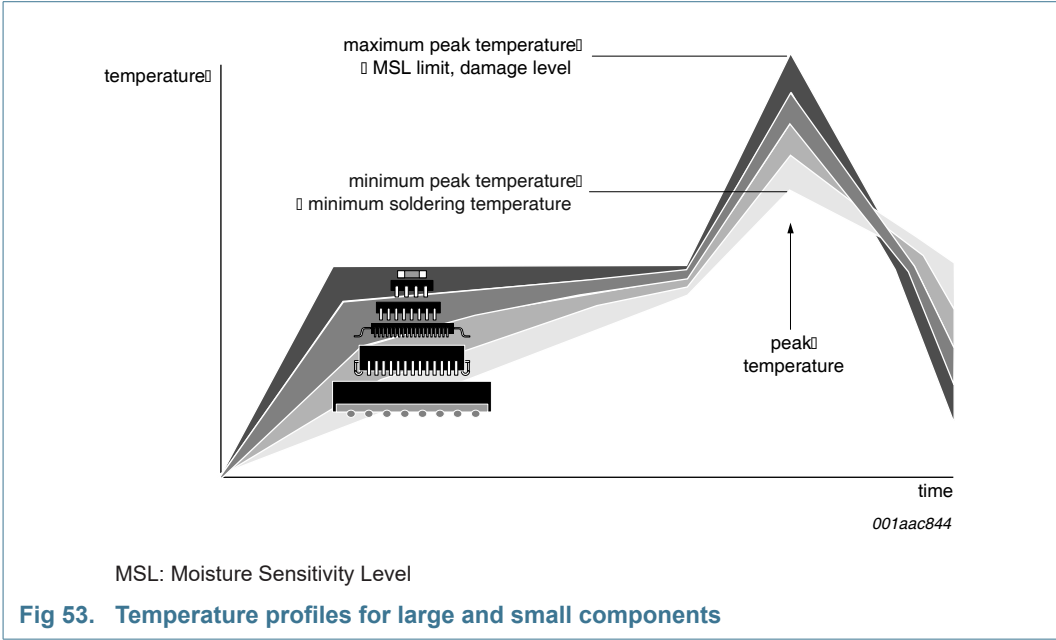

For further information on temperature profiles, refer to Application Note AN10365 “Surface mount reflow soldering description”.

19. Abbreviations

Table 41. Abbreviations

Acronym	Description
ADC	Analog to Digital Converter
ADE	Antenna diversity Even
ADO	Antenna diversity Odd
AES	Advanced Encryption Standard
AGC	Automatic Gain Control
API	Application Program Interface
APT	Analog Peripheral Timer
BOM	Bill Of Material
BOR	Brown-Out Reset
CCA	Clear Channel Assessment
CCM	Counter with CBC-MAC
CDM	Charged Device Model
CLK	CLock
CPU	Central Processing Unit
CRC	Cyclic redundancy Check
CSMA/CA	Carrier Sense Multiple Access with Collision Avoidance
CTS	Clear-To-Send
CW	Continuous Wave
DC	Direct current
DIO	Digital Input Output
DMA	Direct memory Access
DO	Digital Output
ED	Energy Detection
EEPROM	Electrically-Erasable Programmable Read Only Memory
ESR	Equivalent Series Resistance
FIFO	First In First Out
GP	General Purpose
GPIO	General Purpose Input Output
HBM	Human Body Model
HS	High Speed
HVQFN	Heatsink Very-thin Quad Flat No-Leads
ID	IDentification
IF	Intermediate frequency
IO	Input Output
IoT	Internet of Things
IPC	Interconnecting and Packaging Electronic Circuits
JTAG	Joint Test Action Group
LNA	Low Noise Amplifier
LQI	Link Quality Indication

Table 41. Abbreviations ...continued

Acronym	Description
LSB	Low Significant Bit
MAC	Media Access Control
MSB	Most Significant Bit
MSIF	Master Serial InterFace
MSL	Moisture sensitivity level
NACK	Not ACKnowledge
NFET	Negative Field Effect Transistor
NRZ	Non-Return-to-Zero
NVIC	Nested Vector Interrupt Controller
OOK	On-Off Key
OTA	Over-The-Air
OTP	One Time Programmable
PA	Power Amplifier
PAN	Personal Area Network
PCB	Printed-Circuit Board
PDM	Persistent Data Manager
PHY	PHYsical
PLL	Phase-Locked Loop
POR	Power-On Reset
PPF	Palladium Pre Plated
PWM	Pulse Width Modulation
RAM	Random Access Memory
RF	Radio Frequency
RoHS	Restriction of Hazardous Substances
RSSI	Receive Signal Strength Indication
RTS	Request-To-Send
RTOS	Real-Time Operating System
RTZ	Return-To-Zero
RX	Received
SCL	Serial CLock
SDA	Serial DatA
SDK	Software Developer's Kit
SMBus	System Management bus
SMDs	Surface Mount Devices
SPDT	Single-Pole Double-Throw
SPI-bus	Serial Peripheral Interface -bus
STSD	Slave Transmitter Stop Detect
SSIF	Slave Serial InterFace
SVM	Supply Voltage Monitor
SYNTH	SYNTHesizer
SysTick	System Tick timer

Table 41. Abbreviations ...continued

Acronym	Description
TAF	Transmitter Arbitration Failure
TCM	Tightly-Coupled Memory
TX	Transmit
UART	Universal Asynchronous Receiver Transmitter
VCO	Voltage Controlled Oscillator
VTOR	Vector Table Offset Register

20. References

- [1] **Wireless Connectivity** — <http://www.nxp.com/products/wireless-connectivity:WIRELESS-CONNECTIVITY>

21. Revision history

Table 42. Revision history

Document ID	Release date	Data sheet status	Change notice	Supersedes
JN5169 v1.4	20200312	Product data sheet	-	JN5169 v1.3
Modifications:	<ul style="list-style-type: none"> Updated Table 1 "Ordering information". 			
JN5169 v1.3	20170922	Product data sheet	-	JN5169 v1.2
JN5169 v1.2	20160503	Product data sheet	-	JN5169 v1.1
JN5169 v1.1	20151006	Product data sheet	-	JN5169 v1
JN5169 v1	20150730	Product data sheet	-	-
Modifications:	<ul style="list-style-type: none"> Initial version. 			

22. Legal information

22.1 Data sheet status

Document status ^{[1][2]}	Product status ^[3]	Definition
Objective [short] data sheet	Development	This document contains data from the objective specification for product development.
Preliminary [short] data sheet	Qualification	This document contains data from the preliminary specification.
Product [short] data sheet	Production	This document contains the product specification.

[1] Please consult the most recently issued document before initiating or completing a design.

[2] The term 'short data sheet' is explained in section "Definitions".

[3] The product status of device(s) described in this document may have changed since this document was published and may differ in case of multiple devices. The latest product status information is available on the Internet at URL <http://www.nxp.com>.

22.2 Definitions

Draft — The document is a draft version only. The content is still under internal review and subject to formal approval, which may result in modifications or additions. NXP Semiconductors does not give any representations or warranties as to the accuracy or completeness of information included herein and shall have no liability for the consequences of use of such information.

Short data sheet — A short data sheet is an extract from a full data sheet with the same product type number(s) and title. A short data sheet is intended for quick reference only and should not be relied upon to contain detailed and full information. For detailed and full information see the relevant full data sheet, which is available on request via the local NXP Semiconductors sales office. In case of any inconsistency or conflict with the short data sheet, the full data sheet shall prevail.

Product specification — The information and data provided in a Product data sheet shall define the specification of the product as agreed between NXP Semiconductors and its customer, unless NXP Semiconductors and customer have explicitly agreed otherwise in writing. In no event however, shall an agreement be valid in which the NXP Semiconductors product is deemed to offer functions and qualities beyond those described in the Product data sheet.

22.3 Disclaimers

Limited warranty and liability — Information in this document is believed to be accurate and reliable. However, NXP Semiconductors does not give any representations or warranties, expressed or implied, as to the accuracy or completeness of such information and shall have no liability for the consequences of use of such information. NXP Semiconductors takes no responsibility for the content in this document if provided by an information source outside of NXP Semiconductors.

In no event shall NXP Semiconductors be liable for any indirect, incidental, punitive, special or consequential damages (including - without limitation - lost profits, lost savings, business interruption, costs related to the removal or replacement of any products or rework charges) whether or not such damages are based on tort (including negligence), warranty, breach of contract or any other legal theory.

Notwithstanding any damages that customer might incur for any reason whatsoever, NXP Semiconductors' aggregate and cumulative liability towards customer for the products described herein shall be limited in accordance with the *Terms and conditions of commercial sale* of NXP Semiconductors.

Right to make changes — NXP Semiconductors reserves the right to make changes to information published in this document, including without limitation specifications and product descriptions, at any time and without notice. This document supersedes and replaces all information supplied prior to the publication hereof.

Suitability for use — NXP Semiconductors products are not designed, authorized or warranted to be suitable for use in life support, life-critical or safety-critical systems or equipment, nor in applications where failure or malfunction of an NXP Semiconductors product can reasonably be expected to result in personal injury, death or severe property or environmental damage. NXP Semiconductors and its suppliers accept no liability for inclusion and/or use of NXP Semiconductors products in such equipment or applications and therefore such inclusion and/or use is at the customer's own risk.

Applications — Applications that are described herein for any of these products are for illustrative purposes only. NXP Semiconductors makes no representation or warranty that such applications will be suitable for the specified use without further testing or modification.

Customers are responsible for the design and operation of their applications and products using NXP Semiconductors products, and NXP Semiconductors accepts no liability for any assistance with applications or customer product design. It is customer's sole responsibility to determine whether the NXP Semiconductors product is suitable and fit for the customer's applications and products planned, as well as for the planned application and use of customer's third party customer(s). Customers should provide appropriate design and operating safeguards to minimize the risks associated with their applications and products.

NXP Semiconductors does not accept any liability related to any default, damage, costs or problem which is based on any weakness or default in the customer's applications or products, or the application or use by customer's third party customer(s). Customer is responsible for doing all necessary testing for the customer's applications and products using NXP Semiconductors products in order to avoid a default of the applications and the products or of the application or use by customer's third party customer(s). NXP does not accept any liability in this respect.

Limiting values — Stress above one or more limiting values (as defined in the Absolute Maximum Ratings System of IEC 60134) will cause permanent damage to the device. Limiting values are stress ratings only and (proper) operation of the device at these or any other conditions above those given in the Recommended operating conditions section (if present) or the Characteristics sections of this document is not warranted. Constant or repeated exposure to limiting values will permanently and irreversibly affect the quality and reliability of the device.

Terms and conditions of commercial sale — NXP Semiconductors products are sold subject to the general terms and conditions of commercial sale, as published at <http://www.nxp.com/profile/terms>, unless otherwise agreed in a valid written individual agreement. In case an individual agreement is concluded only the terms and conditions of the respective agreement shall apply. NXP Semiconductors hereby expressly objects to applying the customer's general terms and conditions with regard to the purchase of NXP Semiconductors products by customer.

No offer to sell or license — Nothing in this document may be interpreted or construed as an offer to sell products that is open for acceptance or the grant, conveyance or implication of any license under any copyrights, patents or other industrial or intellectual property rights.

Export control — This document as well as the item(s) described herein may be subject to export control regulations. Export might require a prior authorization from competent authorities.

Quick reference data — The Quick reference data is an extract of the product data given in the Limiting values and Characteristics sections of this document, and as such is not complete, exhaustive or legally binding.

Non-automotive qualified products — Unless this data sheet expressly states that this specific NXP Semiconductors product is automotive qualified, the product is not suitable for automotive use. It is neither qualified nor tested in accordance with automotive testing or application requirements. NXP Semiconductors accepts no liability for inclusion and/or use of non-automotive qualified products in automotive equipment or applications.

In the event that customer uses the product for design-in and use in automotive applications to automotive specifications and standards, customer (a) shall use the product without NXP Semiconductors' warranty of the product for such automotive applications, use and specifications, and (b)

whenever customer uses the product for automotive applications beyond NXP Semiconductors' specifications such use shall be solely at customer's own risk, and (c) customer fully indemnifies NXP Semiconductors for any liability, damages or failed product claims resulting from customer design and use of the product for automotive applications beyond NXP Semiconductors' standard warranty and NXP Semiconductors' product specifications.

Translations — A non-English (translated) version of a document is for reference only. The English version shall prevail in case of any discrepancy between the translated and English versions.

22.4 Trademarks

Notice: All referenced brands, product names, service names and trademarks are the property of their respective owners.

I²C-bus — logo is a trademark of NXP Semiconductors N.V.

23. Contact information

For more information, please visit: <http://www.nxp.com>

For sales office addresses, please send an email to: salesaddresses@nxp.com

24. Tables

Table 1.	Ordering information	.4
Table 2.	Pin description	.8
Table 3.	Interrupt vectors	.23
Table 4.	SPI-bus master I/O	.34
Table 5.	SPI-bus configurations	.35
Table 6.	SPI-bus slave I/O	.37
Table 7.	Timer and PWM I/O	.39
Table 8.	UART I/O	.47
Table 9.	2-wire serial interface I/O	.49
Table 10.	List of 2-wire serial interface reserved addresses	52
Table 11.	ADC maximum input range	.54
Table 12.	Limiting values	.59
Table 13.	Operating conditions	.60
Table 14.	Thermal characteristics	.60
Table 15.	Active processing	.60
Table 16.	Sleep mode	.61
Table 17.	Deep sleep mode	.61
Table 18.	I/O characteristics	.62
Table 19.	Externally applied reset	.63
Table 20.	SPI-bus master timing	.65
Table 21.	SPI-bus slave timing	.65
Table 22.	2-wire serial interface	.66
Table 23.	Wake-up timings	.67
Table 24.	Band gap reference	.67
Table 25.	Analog to Digital Converters	.67
Table 26.	Comparator	.68
Table 27.	32 kHz RC oscillator	.69
Table 28.	32 kHz crystal oscillator	.69
Table 29.	32 MHz crystal oscillator	.69
Table 30.	High-speed RC oscillator	.70
Table 31.	Temperature sensor	.70
Table 32.	Non-volatile memory	.70
Table 33.	RF port characteristics	.71
Table 34.	Radio transceiver characteristics: +25 °C	.71
Table 35.	Radio transceiver characteristics: -40 °C	.72
Table 36.	Radio transceiver characteristics: +125 °C	.74
Table 37.	Components	.77
Table 38.	Components	.79
Table 39.	SnPb eutectic process (from J-STD-020C)	.84
Table 40.	Lead-free process (from J-STD-020C)	.84
Table 41.	Abbreviations	.86
Table 42.	Revision history	.89

25. Figures

Fig 1.	Block diagram	5		
Fig 2.	Functional block diagram	6		
Fig 3.	Pin configuration	7		
Fig 4.	Analog I/O cell	12		
Fig 5.	DIO equivalent schematic	13		
Fig 6.	JN5169 memory map	15		
Fig 7.	Connecting external serial memory	16		
Fig 8.	System and CPU clocks	17		
Fig 9.	32 MHz crystal oscillator connections	19		
Fig 10.	32 kHz crystal oscillator connections	20		
Fig 11.	Internal Power-On Reset	21		
Fig 12.	External reset generation	22		
Fig 13.	External reset	22		
Fig 14.	Radio architecture	25		
Fig 15.	External radio components	27		
Fig 16.	Simple antenna diversity implementation using external RF switch	28		
Fig 17.	Antenna diversity ADO signal for TX with acknowledgement	28		
Fig 18.	Modem architecture	29		
Fig 19.	Energy detect value versus receive power level	29		
Fig 20.	Baseband processor	30		
Fig 21.	Security coprocessor architecture	31		
Fig 22.	DIO block diagram	33		
Fig 23.	SPI-bus block diagram	34		
Fig 24.	Typical JN5169 SPI-bus peripheral connection	35		
Fig 25.	Example SPI-bus waveforms: reading from Flash device using mode 0	36		
Fig 26.	Timer unit block diagram	38		
Fig 27.	PWM output timings	40		
Fig 28.	Capture mode	40		
Fig 29.	Return-To-Zero mode in operation	41		
Fig 30.	Non-Return-To-Zero mode in operation	42		
Fig 31.	Closed-loop PWM speed control using JN5169 timers	42		
Fig 32.	Tick timer	43		
Fig 33.	UART block diagram	46		
Fig 34.	JN5169 serial communication link	48		
Fig 35.	Connection details	50		
Fig 36.	Clock stretching	50		
Fig 37.	Multi-master clock synchronization	51		
Fig 38.	Analog peripherals	53		
Fig 39.	ADC input equivalent circuit	54		
Fig 40.	Internal Power-On Reset without showing Brown-Out	62		
Fig 41.	Externally applied reset	63		
Fig 42.	Brown-Out Reset followed by Supply Voltage Monitor trigger	64		
Fig 43.	SPI-bus master timing	64		
Fig 44.	SPI-bus slave timing	65		
Fig 45.	2-wire serial interface timing	66		
Fig 46.	Control range output power	75		
Fig 47.	Receiver sensitivity versus temperature	76		
Fig 48.	JN5169 PCB antenna module reference design	77		
Fig 49.	Application diagram with Pi filter	78		
Fig 50.	Recommended reflow profile for lead-free solder paste (SNAgCu) or PPF lead frame	80		
Fig 51.	Reflow soldering information for the HVQFN40 package	81		
Fig 52.	Package outline SOT618-8 HVQFN40	82		
Fig 53.	Temperature profiles for large and small components	85		

26. Contents

1	General description	1	9.4.5	Watchdog timer	23
2	Features and benefits	1	9.5	Interrupt system	23
2.1	Benefits	1	9.5.1	System calls	24
2.2	Features: radio	1	9.5.2	Processor exceptions	24
2.3	Features: microcontroller	2	9.5.2.1	Bus error	24
3	Applications	2	9.5.2.2	Alignment	24
4	Overview	3	9.5.2.3	Illegal instruction	24
4.1	Wireless transceiver	3	9.5.2.4	Stack overflow	24
4.2	RISC CPU and memory	3	9.5.3	Hardware interrupts	24
4.3	Peripherals	4	9.6	Wireless transceiver	25
5	Ordering information	4	9.6.1	Radio	25
6	Block diagram	5	9.6.1.1	Radio external components	26
7	Functional diagram	6	9.6.1.2	Antenna diversity	27
8	Pinning information	7	9.6.2	Modem	28
8.1	Pinning	7	9.6.3	Baseband processor	30
8.2	Pin description	8	9.6.3.1	Transmit	30
8.2.1	Power supplies	11	9.6.3.2	Reception	31
8.2.2	Reset	11	9.6.3.3	Auto acknowledge	31
8.2.3	32 MHz oscillator	11	9.6.3.4	Security	31
8.2.4	Radio	11	9.6.4	Security coprocessor	31
8.2.5	Analog peripherals	12	9.7	Digital Input/Output	32
8.2.6	Digital Input/Output	12	9.8	Serial Peripheral Interface-bus	33
9	Functional description	13	9.8.1	SPI-bus master	33
9.1	CPU	13	9.8.2	SPI-bus slave	37
9.2	Memory organization	14	9.9	Timers	37
9.2.1	Flash	15	9.9.1	Peripheral timer/counters	37
9.2.2	RAM	15	9.9.2	Pulse Width Modulation mode	39
9.2.3	OTP configuration memory	16	9.9.3	Capture mode	40
9.2.4	EEPROM	16	9.9.4	Counter/timer mode	40
9.2.5	External memory	16	9.9.5	Delta-sigma mode	41
9.2.6	Peripherals	17	9.9.6	Example timer/counter application	42
9.2.7	Unused memory address	17	9.9.7	Tick timer	42
9.3	System clocks	17	9.9.8	Wake-up timers	43
9.3.1	High-speed (32 MHz) system clock	17	9.9.9	32 kHz RC oscillator calibration	44
9.3.1.1	32 MHz crystal oscillator	18	9.10	Pulse counters	45
9.3.1.2	High-speed RC oscillator	19	9.11	Serial communications	45
9.3.2	Low-speed (32 kHz) system clock	19	9.11.1	Interrupts	47
9.3.2.1	32 kHz RC oscillator	19	9.11.2	UART application	48
9.3.2.2	32 kHz crystal oscillator	20	9.12	JTAG test interface	48
9.3.2.3	32 kHz external clock	20	9.13	2-wire serial interface (I ² C-bus)	48
9.4	Reset	20	9.13.1	Connecting devices	49
9.4.1	Internal Power-On Reset/Brown-Out Reset (BOR)	21	9.13.2	Clock stretching	50
9.4.2	External reset	22	9.13.3	Master 2-wire serial interface	50
9.4.3	Software reset	22	9.13.4	Slave 2-wire serial interface	51
9.4.4	Supply Voltage Monitor (SVM)	22	9.14	Random number generator	52
			9.15	Analog peripherals	53
			9.15.1	Analog to Digital Converter (ADC)	54
			9.15.1.1	Operation	54

continued >>

9.15.1.2	Supply monitor	55	22.3	Disclaimers	90
9.15.1.3	Temperature sensor	55	22.4	Trademarks	91
9.15.1.4	ADC sample buffer mode	55	23	Contact information	91
9.15.2	Comparator	56	24	Tables	92
10	Power management and sleep modes	56	25	Figures	93
10.1	Operating modes	56	26	Contents	94
10.1.1	Power domains	56			
10.2	Active processing mode	57			
10.2.1	CPU doze	57			
10.3	Sleep mode	57			
10.3.1	Wake-up timer event	58			
10.3.2	DIO event	58			
10.3.3	Comparator event	58			
10.3.4	Pulse counter	59			
10.4	Deep sleep mode	59			
11	Limiting values	59			
12	Recommended operating conditions	60			
13	Thermal characteristics	60			
14	Characteristics	60			
14.1	DC current	60			
14.2	I/O characteristics	62			
14.3	AC characteristics	62			
14.3.1	Reset and Supply Voltage Monitor	62			
14.3.2	SPI-bus master timing	64			
14.3.3	SPI-bus slave timing	65			
14.3.4	2-wire serial interface	66			
14.3.5	Wake-up timings	67			
14.3.6	Band gap reference	67			
14.3.7	Analog to Digital Converters	67			
14.3.8	Comparator	68			
14.3.9	32 kHz RC oscillator	69			
14.3.10	32 kHz crystal oscillator	69			
14.3.11	32 MHz crystal oscillator	69			
14.3.12	High-speed RC oscillator	70			
14.3.13	Temperature sensor	70			
14.3.14	Non-volatile memory	70			
14.3.15	Radio transceiver	70			
15	Application information	76			
15.1	JN5169 module reference designs	76			
15.1.1	Schematic diagram	76			
15.1.2	Application diagram with Pi filter	78			
15.1.3	PCB design and reflow profile	79			
15.1.4	Moisture sensitivity level (MSL)	80			
16	Footprint information for reflow soldering	81			
17	Package outline	82			
18	Soldering of SMD packages	83			
18.1	Introduction to soldering	83			
18.2	Wave and reflow soldering	83			
18.3	Wave soldering	83			
18.4	Reflow soldering	84			
19	Abbreviations	86			
20	References	88			
21	Revision history	89			
22	Legal information	90			
22.1	Data sheet status	90			
22.2	Definitions	90			

How to Reach Us:

Home Page:
nxp.com

Web Support:
nxp.com/support

Information in this document is provided solely to enable system and software implementers to use NXP products. There are no express or implied copyright licenses granted hereunder to design or fabricate any integrated circuits based on the information in this document. NXP reserves the right to make changes without further notice to any products herein.

NXP makes no warranty, representation, or guarantee regarding the suitability of its products for any particular purpose, nor does NXP assume any liability arising out of the application or use of any product or circuit, and specifically disclaims any and all liability, including without limitation consequential or incidental damages. "Typical" parameters that may be provided in NXP data sheets and/or specifications can and do vary in different applications, and actual performance may vary over time. All operating parameters, including "typicals" must be validated for each customer application by customer, customer's technical experts. NXP does not convey any license under its patent rights nor the rights of others. NXP sells products pursuant to standard terms and conditions of sale, which can be found at the following address: nxp.com/SalesTermsandConditions.

While NXP has implemented advanced security features, all products may be subject to unidentified vulnerabilities. Customers are responsible for the design and operation of their applications and products to reduce the effect of these vulnerabilities on customer's applications and products, and NXP accepts no liability for any vulnerability that is discovered. Customers should implement appropriate design and operating safeguards to minimize the risks associated with their applications and products.

NXP, the NXP logo, NXP SECURE CONNECTIONS FOR A SMARTER WORLD, COOLFLUX, EMBRACE, GREENCHIP, HITAG, I2C BUS, ICODE, JCOP, LIFE VIBES, MIFARE, MIFARE CLASSIC, MIFARE DESFire, MIFARE PLUS, MIFARE FLEX, MANTIS, MIFARE ULTRALIGHT, MIFARE4MOBILE, MIGLO, NTAG, ROADLINK, SMARTLX, SMARTMX, STARPLUG, TOPFET, TRENCHMOS, UCODE, Freescale, the Freescale logo, AltiVec, C-5, CodeTEST, CodeWarrior, ColdFire, ColdFire+, C-Ware, the Energy Efficient Solutions logo, Kinetis, Layerscape, MagniV, mobileGT, PEG, PowerQUICC, Processor Expert, QorIQ, QorIQ Qonverge, Ready Play, SafeAssure, the SafeAssure logo, StarCore, Symphony, VortiQa, Vybrid, Airfast, BeeKit, BeeStack, CoreNet, Flexis, MXC, Platform in a Package, QUICC Engine, SMARTMOS, Tower, TurboLink, UMEMS, EdgeScale, EdgeLock, eIQ, and Immersive3D are trademarks of NXP B.V. All other product or service names are the property of their respective owners. AMBA, Arm, Arm7, Arm7TDMI, Arm9, Arm11, Artisan, big.LITTLE, Cordio, CoreLink, CoreSight, Cortex, DesignStart, DynamIQ, Jazelle, Keil, Mali, Mbed, Mbed Enabled, NEON, POP, RealView, SecurCore, Socrates, Thumb, TrustZone, ULINK, ULINK2, ULINK-ME, ULINK-PLUS, ULINKpro, μ Vision, Versatile are trademarks or registered trademarks of Arm Limited (or its subsidiaries) in the US and/or elsewhere. The related technology may be protected by any or all of patents, copyrights, designs and trade secrets. All rights reserved. Oracle and Java are registered trademarks of Oracle and/or its affiliates. The Power Architecture and Power.org word marks and the Power and Power.org logos and related marks are trademarks and service marks licensed by Power.org.

© 2020 NXP B.V.

Document Number: JN5169
Rev.1.4
03/2020

arm

