

# TPS7A7100 1-A, Fast-Transient, Low-Dropout Voltage Regulator

## 1 Features

- Low-Dropout Voltage: 140 mV at 1 A
- $V_{IN}$  Range: 1.5 V to 6.5 V
- Configurable Fixed  $V_{OUT}$  Range: 0.9 V to 3.5 V
- Adjustable  $V_{OUT}$  Range: 0.9 V to 5 V
- Very Good Load- and Line-Transient Response
- Stable With Ceramic Output Capacitor
- 1.5% Accuracy Overline, Overload, and Overtemperature
- Programmable Soft Start
- Power Good (PG) Output
- 3-mm x 3-mm QFN-16 and 5-mm x 5-mm QFN-20 Packages

## 2 Applications

- Wireless Infrastructure: SerDes, FPGA, DSP™
- RF Components: VCO, ADC, DAC, LVDS
- Set-Top Boxes: Amplifier, ADC, DAC, FPGA, DSP
- Wireless LAN, Bluetooth®
- PCs and Printers
- Audio and Visual

## 3 Description

The TPS7A7100 low-dropout (LDO) voltage regulator is designed for applications seeking very-low dropout capability (140 mV at 1 A) with an input voltage from 1.5 V to 6.5 V. The TPS7A7100 offers an innovative, user-configurable, output-voltage setting from 0.9 V to 3.5 V, eliminating external resistors and any associated error.

The TPS7A7100 has very fast load-transient response, is stable with ceramic output capacitors, and supports a better than 2% accuracy over line, load, and temperature. A soft-start pin allows for an application to reduce inrush into the load. Additionally, an open-drain, power-good signal allows for sequencing power rails.

The TPS7A7100 is available in 3-mm x 3-mm, 16-pin VQFN and 5-mm x 5-mm, 20-pin VQFN packages.

### Device Information<sup>(1)</sup>

PART NUMBER	PACKAGE	BODY SIZE (NOM)
TPS7A7100	VQFN (16)	3.00 mm x 3.00 mm
	VQFN (20)	5.00 mm x 5.00 mm

(1) For all available packages, see the orderable addendum at the end of the data sheet.

### Typical Application Circuit

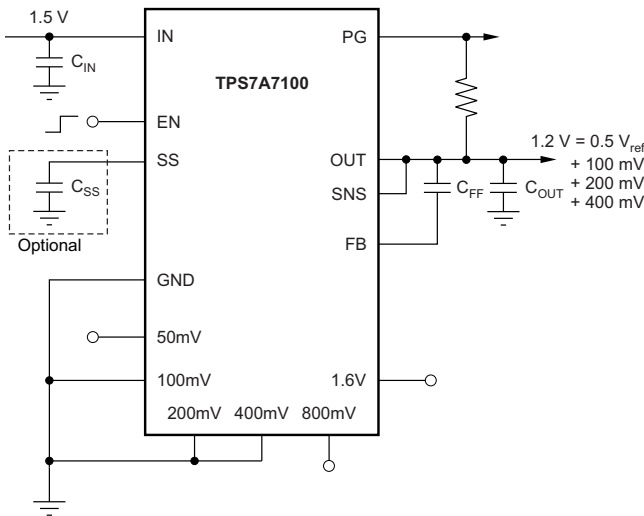

### Load Transient Response With Seven Different Outputs: 1.5 V<sub>IN</sub> to 1 V<sub>OUT</sub>, 1.5 V<sub>IN</sub> to 1.2 V<sub>OUT</sub>, 1.8 V<sub>IN</sub> to 1.5 V<sub>OUT</sub>, 2.5 V<sub>IN</sub> to 1.8 V<sub>OUT</sub>, 3 V<sub>IN</sub> to 2.5 V<sub>OUT</sub>, 3.3 V<sub>IN</sub> to 3 V<sub>OUT</sub>, and 5.5 V<sub>IN</sub> to 5 V<sub>OUT</sub>

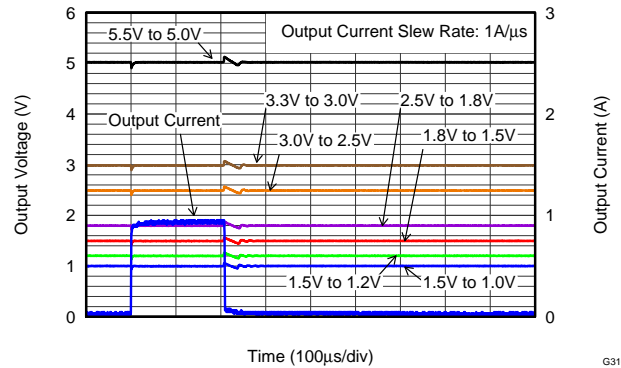

G310



## Table of Contents

<b>1 Features</b> .....	<b>1</b>	<b>8 Application and Implementation</b> .....	<b>22</b>
<b>2 Applications</b> .....	<b>1</b>	8.1 Application Information.....	22
<b>3 Description</b> .....	<b>1</b>	8.2 Typical Application .....	22
<b>4 Revision History</b> .....	<b>2</b>	<b>9 Power Supply Recommendations</b> .....	<b>26</b>
<b>5 Pin Configurations</b> .....	<b>3</b>	<b>10 Layout</b> .....	<b>26</b>
<b>6 Specifications</b> .....	<b>4</b>	10.1 Layout Guidelines .....	26
6.1 Absolute Maximum Ratings .....	4	10.2 Layout Example .....	26
6.2 ESD Ratings.....	4	10.3 Thermal Considerations .....	27
6.3 Recommended Operating Conditions.....	4	10.4 Power Dissipation .....	27
6.4 Thermal Information .....	5	10.5 Estimating Junction Temperature .....	28
6.5 Electrical Characteristics.....	6	<b>11 Device And Documentation Support</b> .....	<b>30</b>
6.6 Typical Characteristics.....	7	11.1 Documentation Support .....	30
<b>7 Detailed Description</b> .....	<b>11</b>	11.2 Community Resource.....	30
7.1 Overview .....	11	11.3 Trademarks .....	30
7.2 Functional Block Diagram .....	11	11.4 Electrostatic Discharge Caution.....	30
7.3 Feature Description.....	12	11.5 Glossary .....	30
7.4 Device Functional Modes.....	21	<b>12 Mechanical, Packaging, And Orderable Information</b> .....	<b>30</b>

## 4 Revision History

NOTE: Page numbers for previous revisions may differ from page numbers in the current version.

Changes from Revision E (September 2013) to Revision F	Page
• Added ESD Ratings table, Feature Description section, Device Functional Modes, Application and Implementation section, Power Supply Recommendations section, Layout section, Device and Documentation Support section, and Mechanical, Packaging, and Orderable Information section .....	1
• Changed from Enable and Shutdown the Device to Enable.....	20

Changes from Revision C (May 2012) to Revision D	Page
• Added C <sub>FF</sub> capacitor to front page block diagram .....	1
• Added text to FB pin description .....	3
• Added C <sub>FF</sub> test condition and table note to Electrical Characteristics.....	6
• Deleted maximum value for Output Current Limit parameter in Electrical Characteristics .....	6
• Added C <sub>FF</sub> capacitor to Figure 22.....	12
• Added C <sub>FF</sub> capacitor to Figure 23.....	13
• Added C <sub>FF</sub> capacitor to Figure 24.....	14
• Added C <sub>FF</sub> capacitor to Figure 25.....	15
• Added C <sub>FF</sub> capacitor to Figure 26.....	16
• Added C <sub>FF</sub> capacitor to Figure 27.....	17
• Added C <sub>FF</sub> capacitor to Figure 28.....	19
• Added C <sub>FF</sub> capacitor to front page block diagram .....	22
• Changed capacitor values in first sentence of Output Capacitor Requirements section .....	23

Changes from Revision B (April 2012) to Revision C	Page
• Added RGT package to Figure 42 .....	27
• Added RGT package to Figure 44 .....	29

## 5 Pin Configurations

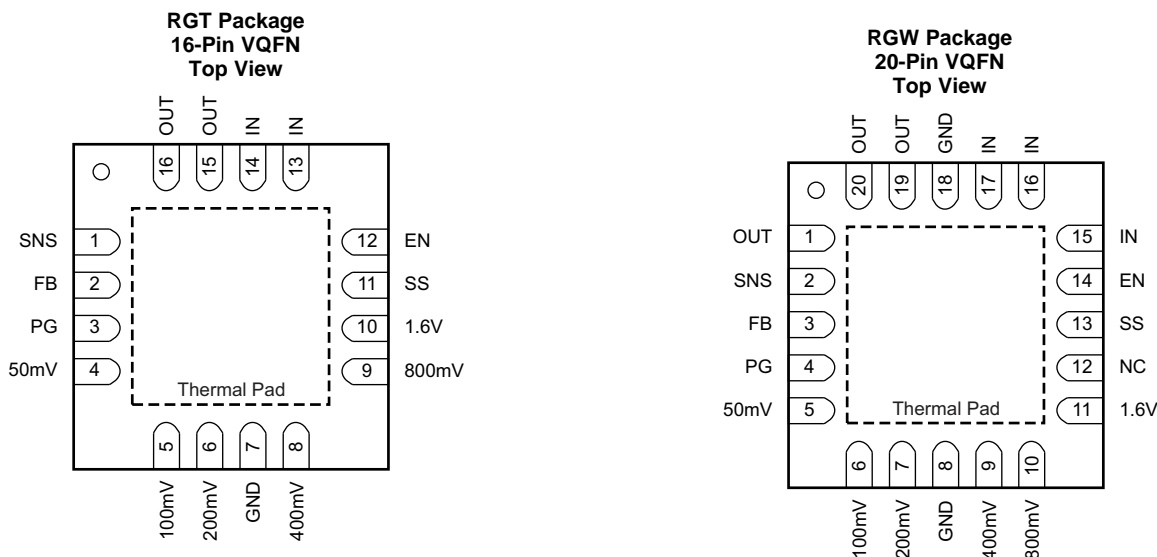

### Pin Functions

PIN		I/O	DESCRIPTION	
NAME	RGW			RGT
50mV, 100mV, 200mV, 400mV, 800mV, 1.6V	5, 6, 7, 9, 10, 11	4, 5, 6, 8, 9, 10	I	Output voltage setting pins. These pins must be connected to ground or left floating. Connecting these pins to ground increases the output voltage by the value of the pin name; multiple pins can be simultaneously connected to GND to select the desired output voltage. Leave these pins floating (open) when not in use. See the <a href="#">User-Configurable Output Voltage</a> section for more details.
EN	14	12	I	Enable pin. Driving this pin to logic high enables the device; driving the pin to logic low disables the device. See the <a href="#">Enable</a> section for more details.
FB	3	2	I	Output voltage feedback pin. Connected to the error amplifier. See the <a href="#">User-Configurable Output Voltage</a> and <a href="#">Traditional Adjustable Configuration</a> sections for more details. TI highly recommends connecting a 220-pF ceramic capacitor from FB pin to OUT.
GND	8, 18	7	—	Ground pin.
IN	15, 16, 17	13, 14	I	Unregulated supply voltage pin. TI recommends connecting an input capacitor to this pin. See <a href="#">Input Capacitor Requirements</a> for more details.
NC	12	—	—	Not internally connected. The NC pin is not connected to any electrical node. TI strongly recommends connecting this pin and the thermal pad to a large-area ground plane. See the <a href="#">Power Dissipation</a> section for more details.
OUT	1, 19, 20	15, 16	O	Regulated output pin. A 4.7- $\mu$ F or larger capacitance is required for stability. See <a href="#">Output Capacitor Requirements</a> for more details.
PG	4	3	O	Active-high power good pin. An open-drain output that indicates when the output voltage reaches 90% of the target. See <a href="#">Power Good</a> for more details.
SNS	2	1	I	Output voltage sense input pin. See the <a href="#">User-Configurable Output Voltage</a> and <a href="#">Traditional Adjustable Configuration</a> sections for more details.
SS	13	11	—	Soft-start pin. Leaving this pin open provides soft start of the default setting. Connecting an external capacitor between this pin and the ground enables the soft-start function by forming an RC-delay circuit in combination with the integrated resistance on the silicon. See the <a href="#">Soft-Start</a> section for more details.
Thermal Pad			—	TI strongly recommends connecting the thermal pad to a large-area ground plane. If available, connect an electrically-floating, dedicated thermal plane to the thermal pad as well.

## 6 Specifications

### 6.1 Absolute Maximum Ratings

Over operating junction temperature range (unless otherwise noted).<sup>(1)</sup>

		MIN	MAX	UNIT
Voltage	IN, PG, EN	-0.3	7	V
	SS, FB, SNS, OUT	-0.3	$V_{IN} + 0.3^{(2)}$	V
	50 mV, 100 mV, 200 mV, 400 mV, 800 mV, 1.6 V	-0.3	$V_{OUT} + 0.3^{(2)}$	V
Current	OUT	Internally limited		A
	PG (sink current into IC)		5	mA
Temperature	Operating virtual junction, $T_J$	-55	160	°C
	Storage, $T_{stg}$	-55	150	°C

- (1) Stresses beyond those listed under *Absolute Maximum Ratings* may cause permanent damage to the device. These are stress ratings only, and functional operation of the device at these or any other conditions beyond those indicated is not implied. Exposure to absolute-maximum-rated conditions for extended periods may affect device reliability.
- (2) The absolute maximum rating is  $V_{IN} + 0.3$  V or +7 V, whichever is smaller.

### 6.2 ESD Ratings

		VALUE	UNIT
$V_{(ESD)}$ Electrostatic discharge	Human-body model (HBM), per ANSI/ESDA/JEDEC JS-001 <sup>(1)</sup>	±2000	V
	Charged-device model (CDM), per JEDEC specification JESD22-C101 <sup>(2)</sup>	±500	

- (1) JEDEC document JEP155 states that 500-V HBM allows safe manufacturing with a standard ESD control process.
- (2) JEDEC document JEP157 states that 250-V CDM allows safe manufacturing with a standard ESD control process.

### 6.3 Recommended Operating Conditions

over operating junction temperature range (unless otherwise noted)

		MIN	NOM	MAX	UNIT
$V_{IN}$	Supply voltage	1.425		6.5	V
$V_{OUT}$	Output voltage	0.9		5	V
$V_{EN}$	Enable voltage	0		6.5	V
$V_{PG}$	Pullup voltage	0		6.5	V
50 mV, 100 mV, 200 mV, 400 mV, 800 mV, 1.6 V	Any-out voltage	0		$V_{OUT}$	
$I_{OUT}$	Output current	0		1	A
$C_{OUT}$	Output capacitance	4.7		200 <sup>(1)</sup>	μF
$C_{FB}$	Feedforward capacitance	0		100	nF
$T_J$	Junction temperature	-40		125	°C

- (1) For output capacitors larger than 47 μF a feedforward capacitor of at least 220 pF must be used.

## 6.4 Thermal Information

THERMAL METRIC <sup>(1)(2)</sup>		TPS7A7100 <sup>(3)</sup>		UNIT
		RGW (VQFN)	RGT (VQFN)	
		20 PINS	16 PINS	
$R_{\theta JA}$	Junction-to-ambient thermal resistance <sup>(4)</sup>	35.7	44.6	°C/W
$R_{\theta JC(top)}$	Junction-to-case (top) thermal resistance <sup>(5)</sup>	33.6	54.3	°C/W
$R_{\theta JB}$	Junction-to-board thermal resistance <sup>(6)</sup>	15.2	17.2	°C/W
$\psi_{JT}$	Junction-to-top characterization parameter <sup>(7)</sup>	0.4	1.1	°C/W
$\psi_{JB}$	Junction-to-board characterization parameter <sup>(8)</sup>	15.4	17.2	°C/W
$R_{\theta JC(bot)}$	Junction-to-case (bottom) thermal resistance <sup>(9)</sup>	3.8	3.8	°C/W

- (1) For more information about traditional and new thermal metrics, see the *Semiconductor and IC Package Thermal Metrics* application report, [SPRA953](#).
- (2) For thermal estimates of this device based on printed-circuit-board (PCB) copper area, see the [TI PCB Thermal Calculator](#).
- (3) Thermal data for the RGW package is derived by thermal simulations based on JEDEC-standard methodology as specified in the JESD51 series. The following assumptions are used in the simulations:
  - (a) i. RGW: The exposed pad is connected to the PCB ground layer through a 4 × 4 thermal via array.
  - ii. RGT: The exposed pad is connected to the PCB ground layer through a 2 × 2 thermal via array.
  - (b) i. RGW: Both the top and bottom copper layers have a dedicated pattern for 4% copper coverage.
  - ii. RGT: Both the top and bottom copper layers have a dedicated pattern for 5% copper coverage.
  - (c) These data were generated with only a single device at the center of a JEDEC high-K (2s2p) board with 3-inch × 3-inch copper area. To understand the effects of the copper area on thermal performance, see the [Power Dissipation](#) and [Estimating Junction Temperature](#) sections.
- (4) The junction-to-ambient thermal resistance under natural convection is obtained in a simulation on a JEDEC-standard, high-K board, as specified in JESD51-7, in an environment described in JESD51-2a.
- (5) The junction-to-case (top) thermal resistance is obtained by simulating a cold plate test on the top of the package. No specific JEDEC-standard test exists, but a close description can be found in the ANSI SEMI standard G30-88.
- (6) The junction-to-board thermal resistance is obtained by simulating in an environment with a ring cold plate fixture to control the PCB temperature, as described in JESD51-8.
- (7) The junction-to-top characterization parameter,  $\psi_{JT}$ , estimates the junction temperature of a device in a real system and is extracted from the simulation data to obtain  $\theta_{JA}$  using a procedure described in JESD51-2a (sections 6 and 7).
- (8) The junction-to-board characterization parameter,  $\psi_{JB}$ , estimates the junction temperature of a device in a real system and is extracted from the simulation data to obtain  $\theta_{JA}$  using a procedure described in JESD51-2a (sections 6 and 7).
- (9) The junction-to-case (bottom) thermal resistance is obtained by simulating a cold plate test on the exposed (power) pad. No specific JEDEC standard test exists, but a close description can be found in the ANSI SEMI standard G30-88.

## 6.5 Electrical Characteristics

Over operating temperature range ( $T_J = -40^\circ\text{C}$  to  $+125^\circ\text{C}$ ),  $1.425\text{ V} \leq V_{IN} \leq 6.5\text{ V}$ ,  $V_{IN} \geq V_{OUT(\text{TARGET})} + 0.3\text{ V}$  or  $V_{IN} \geq V_{OUT(\text{TARGET})} + 0.5\text{ V}$ <sup>(1)(2)</sup>, OUT connected to  $50\ \Omega$  to GND<sup>(3)</sup>,  $V_{EN} = 1.1\text{ V}$ ,  $C_{OUT} = 10\ \mu\text{F}$ ,  $C_{SS} = 10\ \text{nF}$ ,  $C_{FF} = 0\ \text{pF}$  (RGW package),  $C_{FF} = 220\ \text{pF}$  (RGT package)<sup>(4)</sup>, and PG pin pulled up to  $V_{IN}$  with  $100\ \text{k}\Omega$ ,  $27\ \text{k}\Omega \leq R_2 \leq 33\ \text{k}\Omega$  for adjustable configuration<sup>(5)</sup>, unless otherwise noted. Typical values are at  $T_J = 25^\circ\text{C}$ .

PARAMETER		TEST CONDITIONS	MIN	TYP	MAX	UNIT
$V_{IN}$	Input voltage		1.425		6.5	V
$V_{(SS)}$	SS pin voltage			0.5		V
$V_{OUT}$	Output voltage	Adjustable with external feedback resistors	0.9		5	V
		Fixed with voltage setting pins	0.9		3.5	
	Output voltage accuracy <sup>(6)(7)</sup>	RGT package only, adjustable, $-40^\circ\text{C} \leq T_A \leq 85^\circ\text{C}$ , $25\ \text{mA} \leq I_{OUT} \leq 1\ \text{A}$	-1.5%		1.5%	
		RGT package only, fixed, $-40^\circ\text{C} \leq T_A \leq 85^\circ\text{C}$ , $25\ \text{mA} \leq I_{OUT} \leq 1\ \text{A}$	-2%		2%	
		Adjustable, $25\ \text{mA} \leq I_{OUT} \leq 1\ \text{A}$	-2%		2%	
Fixed, $25\ \text{mA} \leq I_{OUT} \leq 1\ \text{A}$	-3%		3%			
$\Delta V_{O(\Delta V)}$	Line regulation	$I_{OUT} = 25\ \text{mA}$		0.01		%/V
$\Delta V_{O(\Delta I)}$	Load regulation	$25\ \text{mA} \leq I_{OUT} \leq 1\ \text{A}$		0.1		%/A
$V_{(DO)}$	Dropout voltage <sup>(8)</sup>	$V_{OUT} \leq 3.3\text{ V}$ , $I_{OUT} = 1\ \text{A}$ , $V_{(FB)} = \text{GND}$			140	mV
		$3.3\text{ V} < V_{OUT}$ , $I_{OUT} = 1\ \text{A}$ , $V_{(FB)} = \text{GND}$			350	mV
$I_{(LIM)}$	Output current limit	$V_{OUT}$ forced at $0.9 \times V_{OUT(\text{TARGET})}$ , $V_{IN} = 3.3\text{ V}$ , $V_{OUT(\text{TARGET})} = 0.9\text{ V}$	1.1	1.6		A
$I_{(GND)}$	GND pin current	Full load, $I_{OUT} = 1\ \text{A}$		1.8		mA
		Minimum load, $V_{IN} = 6.5\text{ V}$ , $V_{OUT(\text{TARGET})} = 0.9\text{ V}$ , $I_{OUT} = 25\ \text{mA}$			4	mA
		Shutdown, PG = (open), $V_{IN} = 6.5\text{ V}$ , $V_{OUT(\text{TARGET})} = 0.9\text{ V}$ , $V_{(EN)} < 0.5\text{ V}$		0.1	5	$\mu\text{A}$
$I_{(EN)}$	EN pin current	$V_{IN} = 6.5\text{ V}$ , $V_{(EN)} = 0\text{ V}$ and $6.5\text{ V}$			$\pm 0.1$	$\mu\text{A}$
$V_{IL(EN)}$	EN pin low-level input voltage (disable device)		0		0.5	V
$V_{IH(EN)}$	EN pin high-level input voltage (enable device)		1.1		6.5	V
$V_{IT(PG)}$	PG pin threshold	For the direction PG $\downarrow$ with decreasing $V_{OUT}$	$0.85V_{OUT}$	$0.9V_{OUT}$	$0.96V_{OUT}$	V
$V_{hys(PG)}$	PG pin hysteresis	For PG $\uparrow$		$0.02V_{OUT}$		V
$V_{OL(PG)}$	PG pin low-level output voltage	$V_{OUT} < V_{IT(PG)}$ , $I_{PG} = -1\ \text{mA}$ (current into device)			0.4	V
$I_{lk(PG)}$	PG pin leakage current	$V_{OUT} > V_{IT(PG)}$ , $V_{(PG)} = 6.5\text{ V}$			1	$\mu\text{A}$
$I_{(SS)}$	SS pin charging current	$V_{(SS)} = \text{GND}$ , $V_{IN} = 3.3\text{ V}$	3.5	5.1	7.2	$\mu\text{A}$
$V_n$	Output noise voltage	BW = 100 Hz to 100 kHz, $V_{IN} = 1.5\text{ V}$ , $V_{OUT} = 1.2\text{ V}$ , $I_{OUT} = 1\ \text{A}$		39.57		$\mu\text{V}_{\text{RMS}}$
$T_{sd}$	Thermal shutdown temperature	Shutdown, temperature increasing		160		$^\circ\text{C}$
		Reset, temperature decreasing		140		$^\circ\text{C}$
$T_J$	Operating junction temperature		-40		125	$^\circ\text{C}$

- (1) When  $V_{OUT} \leq 3.5\text{ V}$ ,  $V_{IN} \geq (V_{OUT} + 0.3\text{ V})$  or  $1.425\text{ V}$ , whichever is greater; when  $V_{OUT} > 3.5\text{ V}$ ,  $V_{IN} \geq (V_{OUT} + 0.5\text{ V})$ .
- (2)  $V_{OUT(\text{TARGET})}$  is the calculated target  $V_{OUT}$  value from the output voltage setting pins: 50 mV, 100 mV, 200 mV, 400 mV, 800 mV, and 1.6 V in fixed configuration, or the expected  $V_{OUT}$  value set by external feedback resistors in adjustable configuration.
- (3) This 50- $\Omega$  load is disconnected when the test conditions specify an  $I_{OUT}$  value.
- (4)  $C_{FF}$  is the capacitor between FB pin and OUT.
- (5)  $R_2$  is the bottom-side of the feedback resistor between the FB pin and GND. See for details.
- (6) When the TPS7A7100 is connected to external feedback resistors at the FB pin, external resistor tolerances are not included.
- (7) The TPS7A7100 is not tested at  $V_{OUT} = 0.9\text{ V}$ ,  $2.7\text{ V} \leq V_{IN} \leq 6.5\text{ V}$ , and  $500\ \text{mA} \leq I_{OUT} \leq 1\ \text{A}$  because the power dissipation is higher than the maximum rating of the package. Also, this accuracy specification does not apply on any application condition that exceeds the power dissipation limit of the package.
- (8)  $V_{(DO)}$  is not defined for output voltage settings less than 1.2 V.

### 6.6 Typical Characteristics

At  $T_J = 25^\circ\text{C}$ ,  $V_{IN} = V_{OUT(TARGET)} + 0.3\text{ V}$ ,  $I_{OUT} = 25\text{ mA}$ ,  $V_{(EN)} = V_{IN}$ ,  $C_{IN} = 10\ \mu\text{F}$ ,  $C_{OUT} = 10\ \mu\text{F}$ ,  $C_{(SS)} = 10\ \text{nF}$ , and the PG pin pulled up to  $V_{IN}$  with 100-k $\Omega$  pullup resistor, unless otherwise noted.

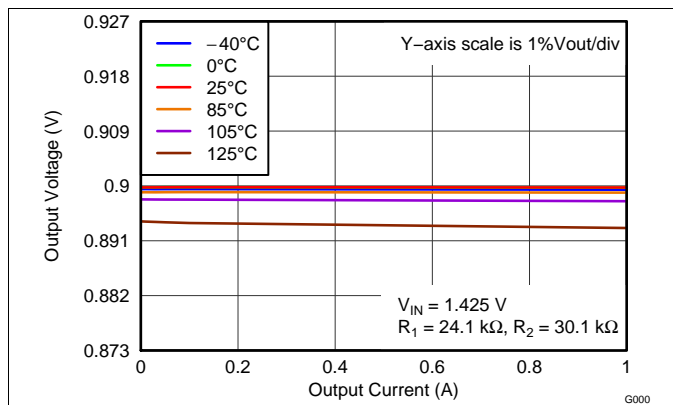

Figure 1. Load Regulation (0.9 V, Adjustable)

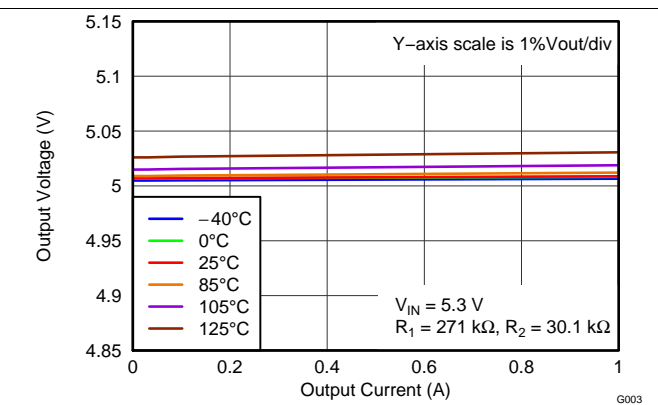

Figure 2. Load Regulation (5 V, Adjustable)

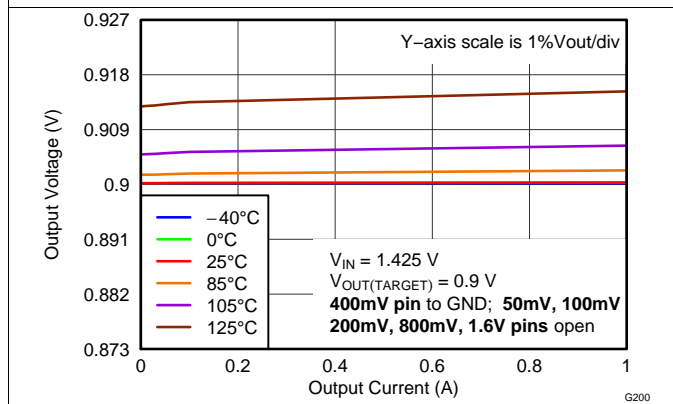

Figure 3. Load Regulation (0.9 V, Fixed By Setting Pins)

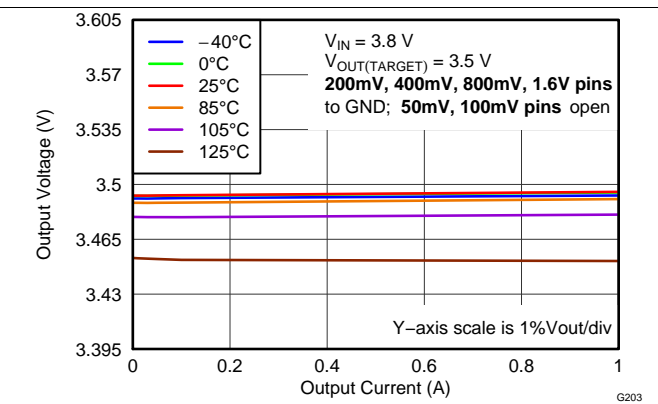

Figure 4. Load Regulation (3.5 V, Fixed By Setting Pins)

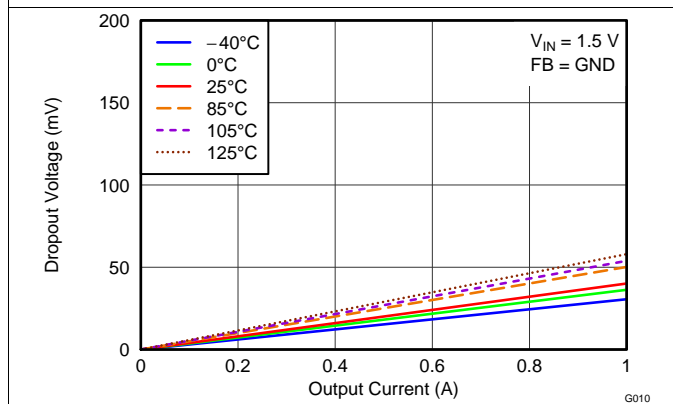

Figure 5. Dropout Voltage vs Output Current

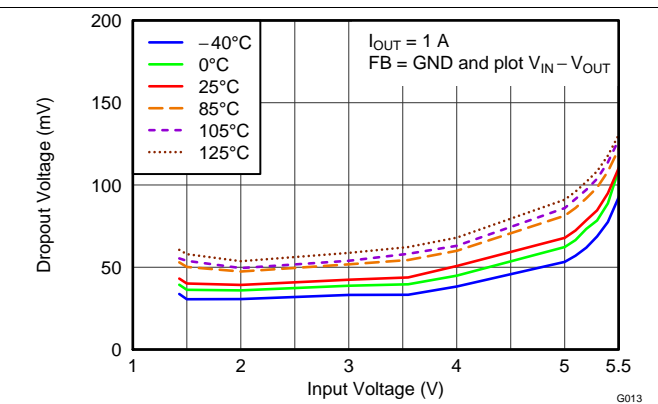

Figure 6. Dropout Voltage vs Temperature

Typical Characteristics (continued)

At  $T_J = 25^\circ\text{C}$ ,  $V_{IN} = V_{OUT(TARGET)} + 0.3\text{ V}$ ,  $I_{OUT} = 25\text{ mA}$ ,  $V_{(EN)} = V_{IN}$ ,  $C_{IN} = 10\ \mu\text{F}$ ,  $C_{OUT} = 10\ \mu\text{F}$ ,  $C_{(SS)} = 10\ \text{nF}$ , and the PG pin pulled up to  $V_{IN}$  with 100-k $\Omega$  pullup resistor, unless otherwise noted.

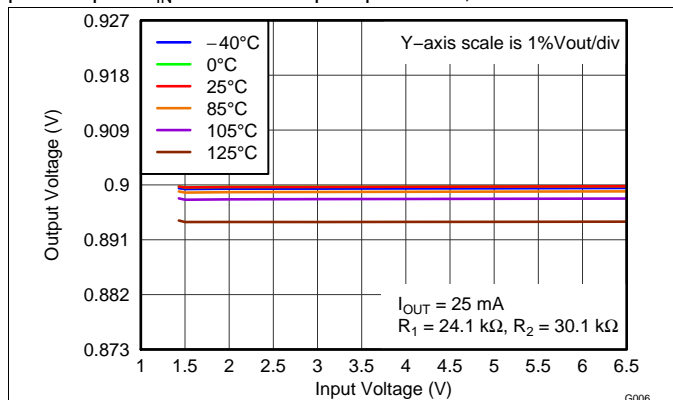

Figure 7. Line Regulation (0.9 V, Adjustable)

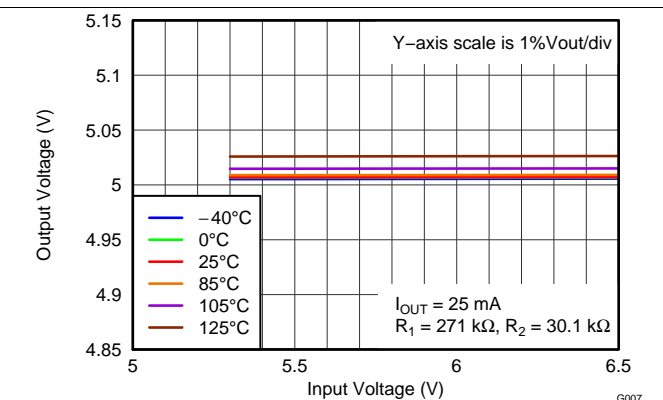

Figure 8. Line Regulation (5 V, Adjustable)

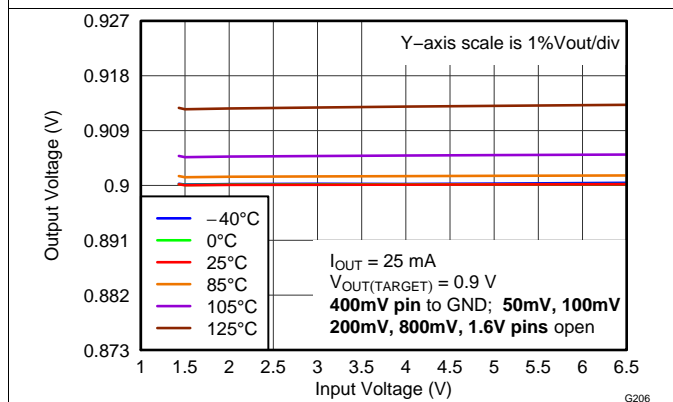

Figure 9. Line Regulation (0.9 V, Fixed By Setting Pins)

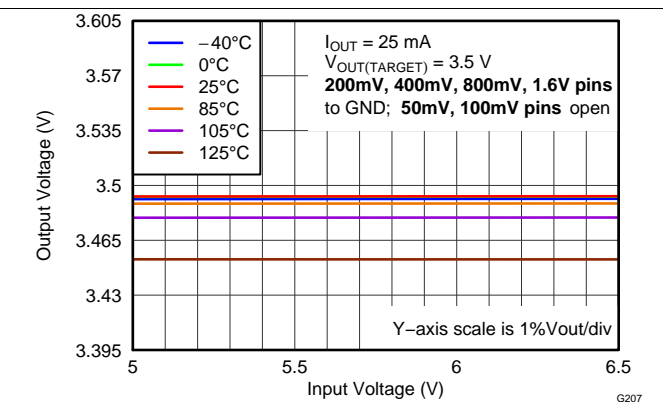

Figure 10. Line Regulation (3.5 V, Fixed By Setting Pins)

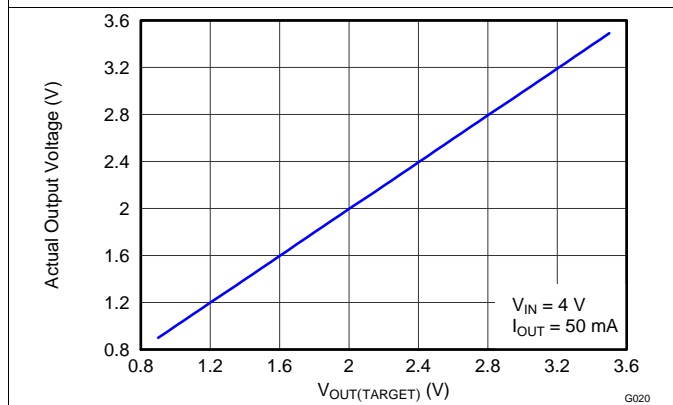

Figure 11. Measured Output Voltage vs Pin-Setting

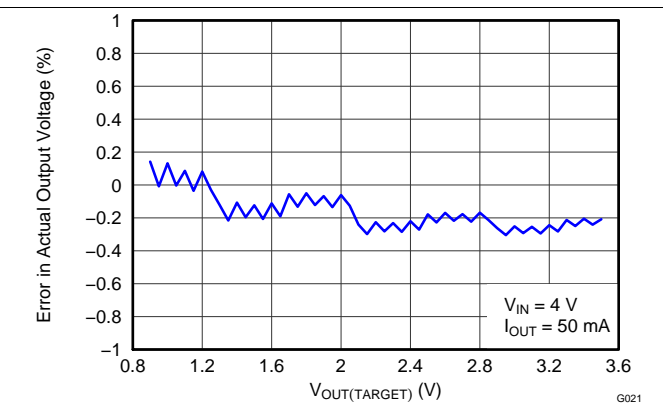
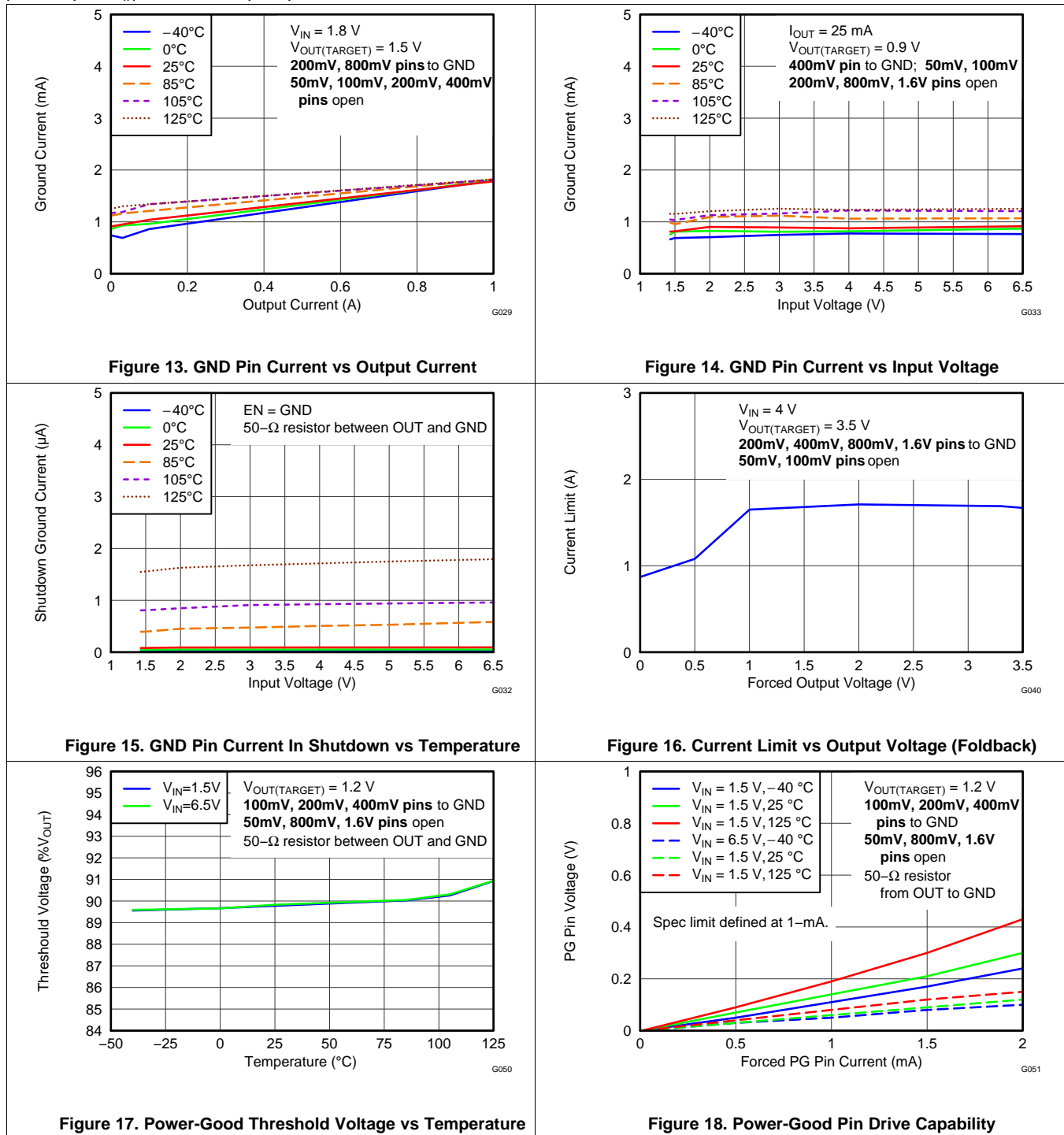

Figure 12. Accuracy vs Pin-Setting



Typical Characteristics (continued)

At  $T_J = 25^\circ\text{C}$ ,  $V_{IN} = V_{OUT(TARGET)} + 0.3\text{ V}$ ,  $I_{OUT} = 25\text{ mA}$ ,  $V_{(EN)} = V_{IN}$ ,  $C_{IN} = 10\ \mu\text{F}$ ,  $C_{OUT} = 10\ \mu\text{F}$ ,  $C_{(SS)} = 10\ \text{nF}$ , and the PG pin pulled up to  $V_{IN}$  with 100-k $\Omega$  pullup resistor, unless otherwise noted.



Typical Characteristics (continued)

At  $T_J = 25^\circ\text{C}$ ,  $V_{IN} = V_{OUT(TARGET)} + 0.3\text{ V}$ ,  $I_{OUT} = 25\text{ mA}$ ,  $V_{(EN)} = V_{IN}$ ,  $C_{IN} = 10\ \mu\text{F}$ ,  $C_{OUT} = 10\ \mu\text{F}$ ,  $C_{(SS)} = 10\ \text{nF}$ , and the PG pin pulled up to  $V_{IN}$  with 100-k $\Omega$  pullup resistor, unless otherwise noted.

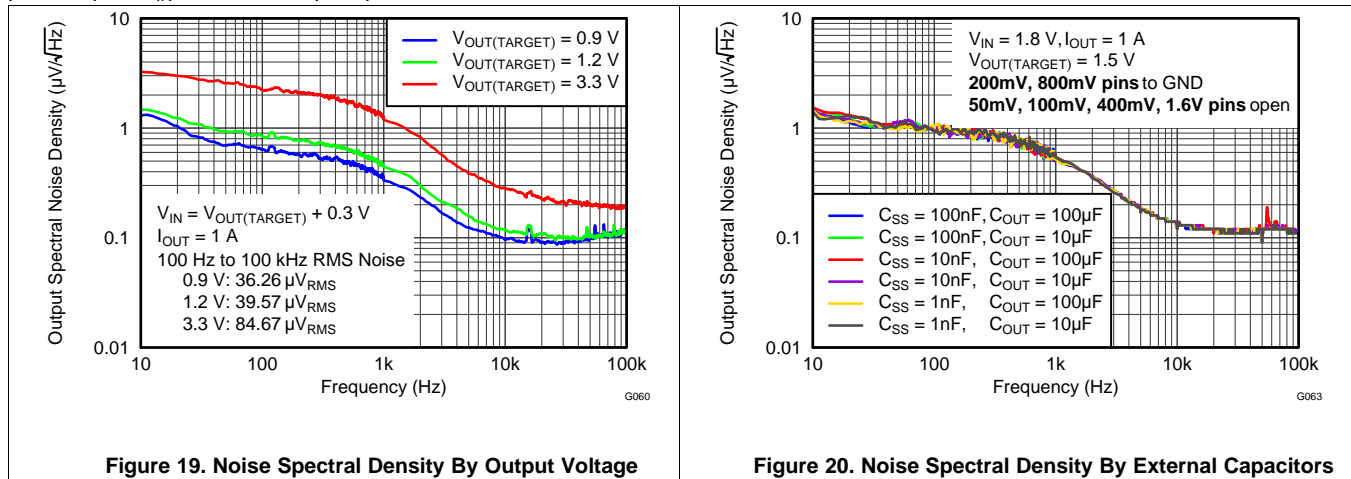

Figure 19. Noise Spectral Density By Output Voltage

Figure 20. Noise Spectral Density By External Capacitors

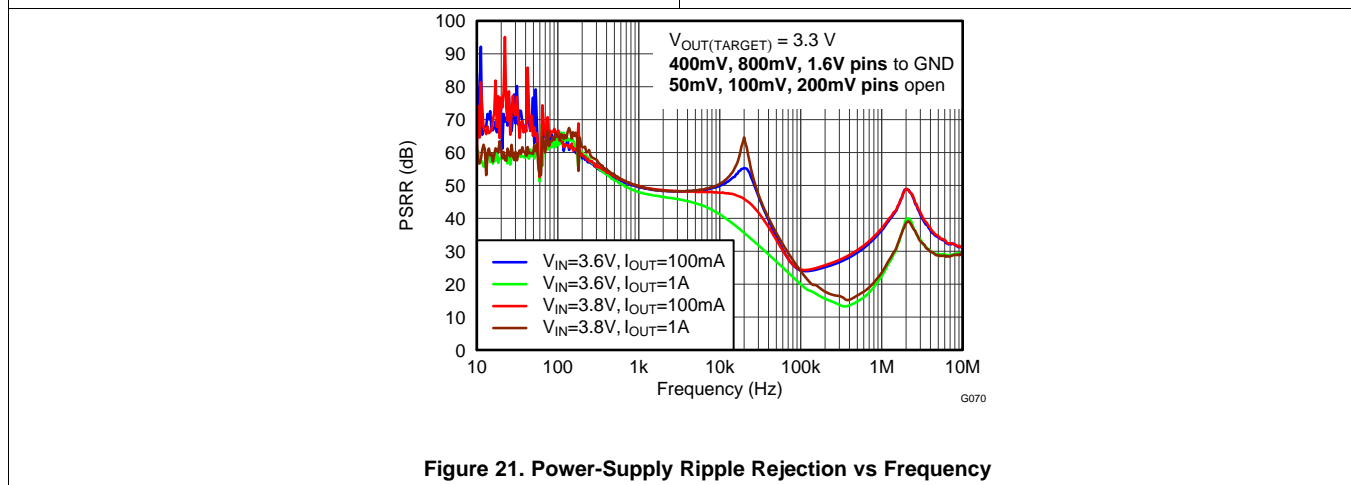

Figure 21. Power-Supply Ripple Rejection vs Frequency

## 7 Detailed Description

### 7.1 Overview

The TPS7A7100 belongs to a family of new-generation LDO regulators that uses innovative circuitry to offer very-low dropout voltage along with the flexibility of a programmable output voltage.

The dropout voltage for this LDO regulator family is 0.14 V at 1 A. This voltage is ideal for making the TPS7A7100 into a point-of-load (POL) regulator because 0.14 V at 1 A is lower than any voltage gap among the most common voltage rails: 1.2 V, 1.5 V, 1.8 V, 2.5 V, 3 V, and 3.3 V. This device offers a fully user-configurable output voltage setting method. The TPS7A7100 output voltage can be programmed to any target value from 0.9 V to 3.5 V in 50-mV steps.

Another big advantage of using the TPS7A7100 is the wide range of available operating input voltages: from 1.5 V to 6.5 V. The TPS7A7100 also has very good line and load transient response. All these features allow the TPS7A7100 to meet most voltage-regulator needs for under 6-V applications, using only one device so less time is spent on inventory control.

Texas Instruments also offers different output current ratings with other family devices: the [TPS7A7200](#) (2 A) and [TPS7A7300](#) (3 A).

### 7.2 Functional Block Diagram

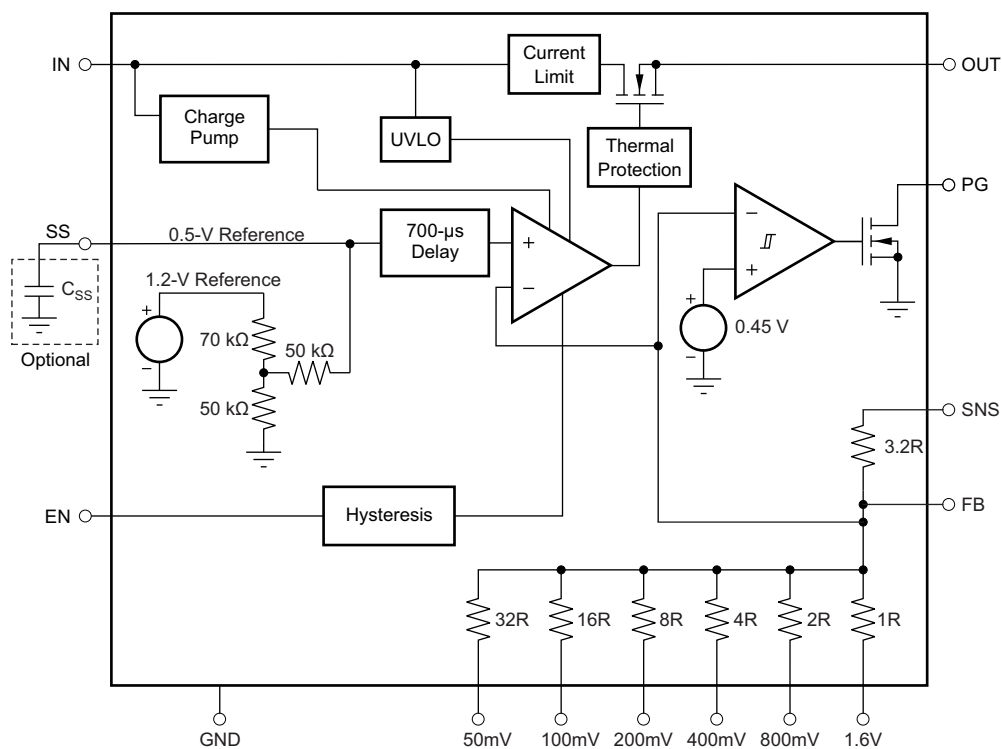

NOTE: 32R = 1.024 MΩ (that is, 1R = 32 kΩ).

### 7.3 Feature Description

#### 7.3.1 User-Configurable Output Voltage

Unlike traditional LDO devices, the TPS7A7100 comes with only one orderable part number; there is no adjustable or fixed output voltage option. The output voltage of the TPS7A7100 is selectable in accordance with the names given to the output voltage setting pins: 50 mV, 100 mV, 200 mV, 400 mV, 800 mV, and 1.6 V. For each pin connected to the ground, the output voltage setting increases by the value associated with that pin name, starting from the value of the reference voltage of 0.5 V; floating the pins has no effect on the output voltage. Figure 22 through Figure 27 show examples of how to program the output voltages.

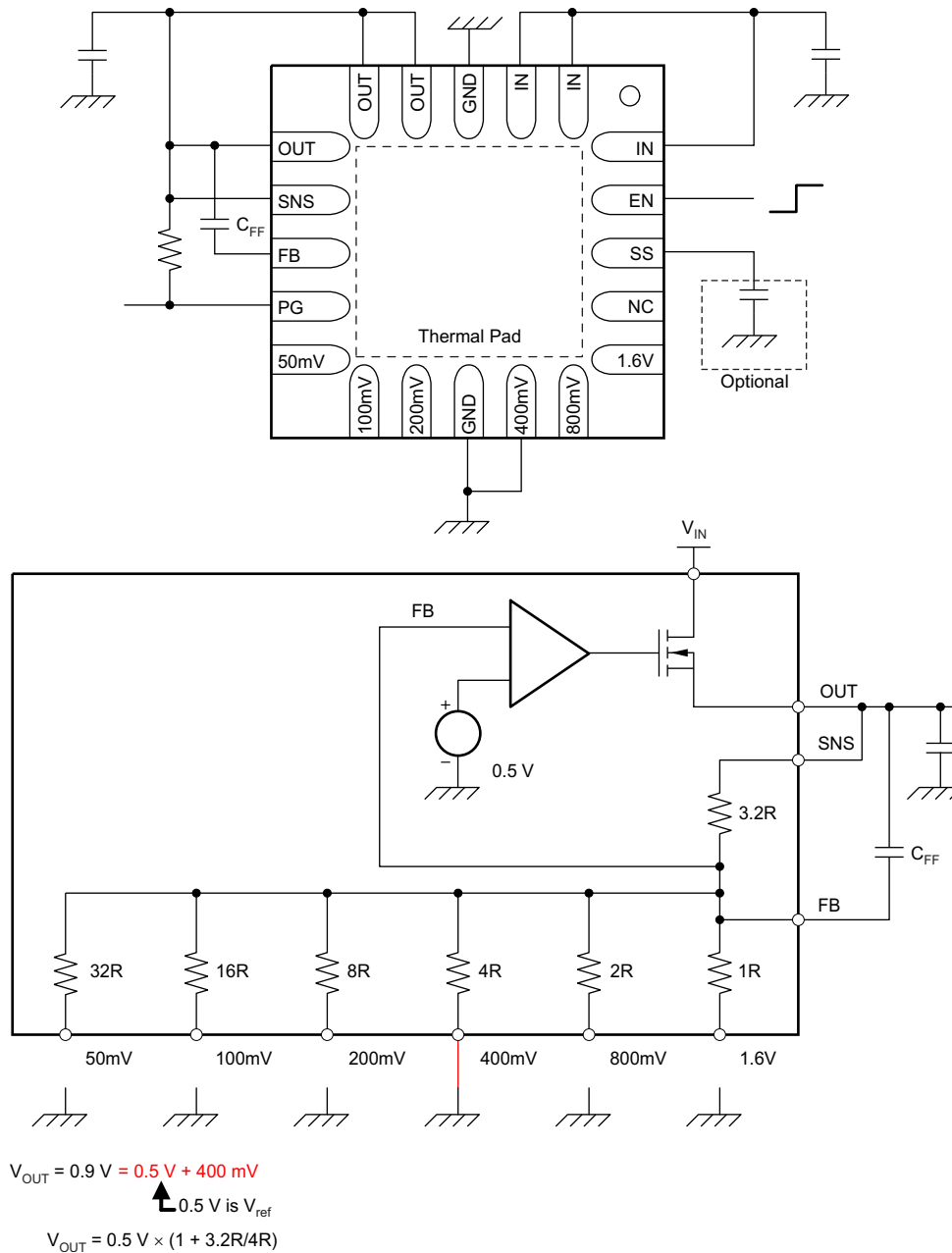
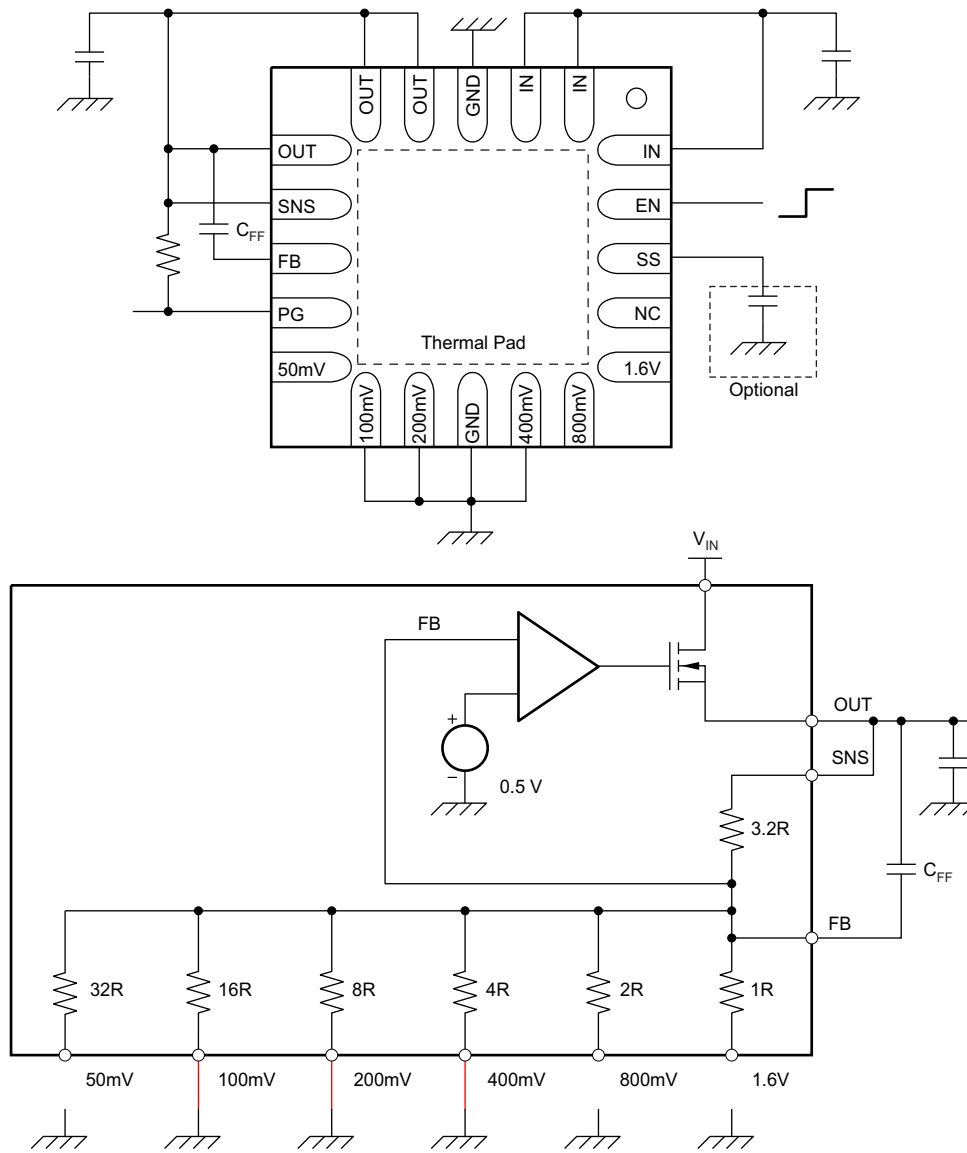

Figure 22. 0.9-V Configuration

Feature Description (continued)



$$V_{OUT} = 1.2\text{ V} = 0.5\text{ V} + 100\text{ mV} + 200\text{ mV} + 400\text{ mV}$$

0.5 V is  $V_{ref}$

$$V_{OUT} = 0.5\text{ V} \times (1 + 3.2R/2.29R) \quad 2.29R \text{ is parallel resistance of } 16R, 8R, \text{ and } 4R.$$

Figure 23. 1.2-V Configuration

Feature Description (continued)

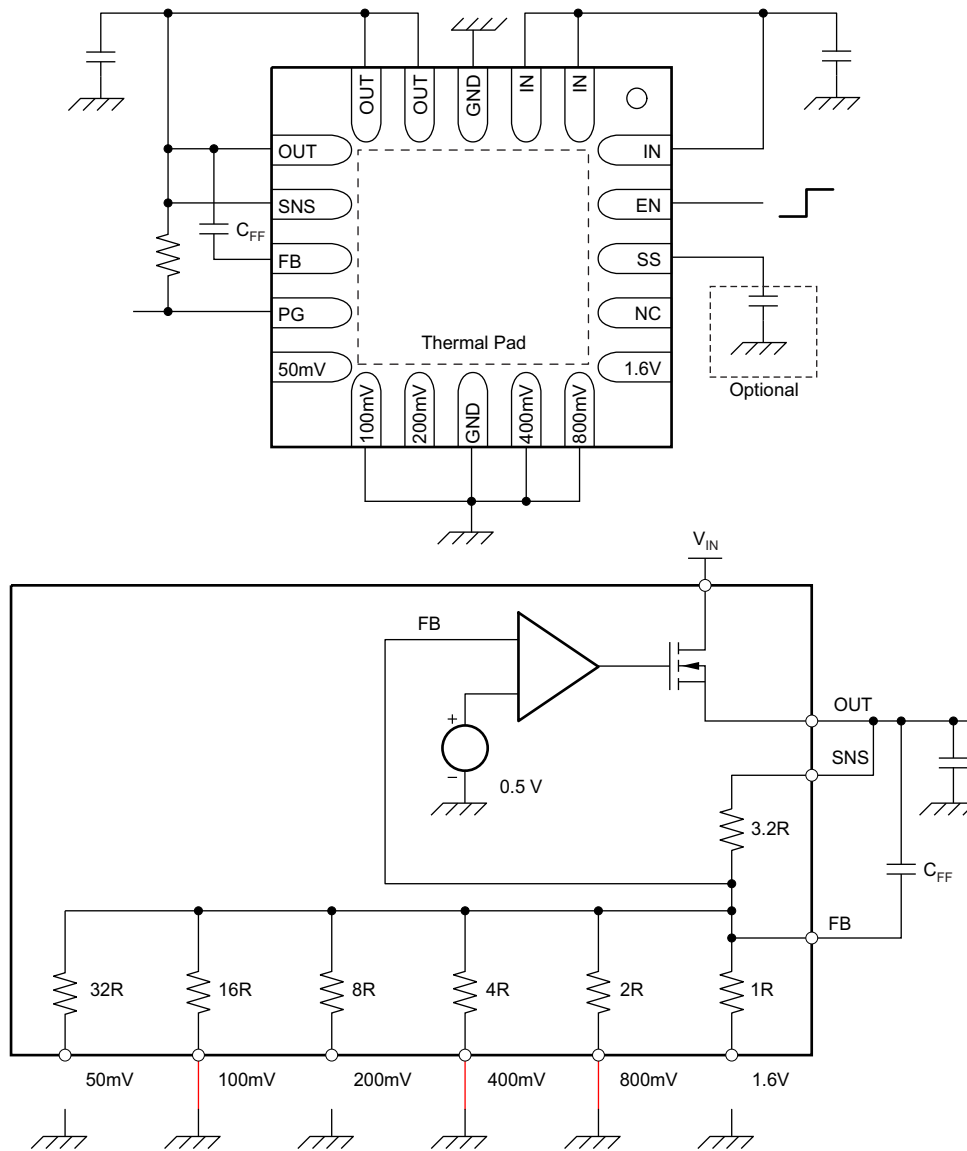

$$V_{OUT} = 1.8\text{ V} = 0.5\text{ V} + 100\text{ mV} + 400\text{ mV} + 800\text{ mV}$$

0.5 V is  $V_{ref}$

$$V_{OUT} = 0.5\text{ V} \times (1 + 3.2R/1.23R) \quad 1.23R \text{ is parallel resistance of } 16R, 4R, \text{ and } 2R.$$

Figure 24. 1.8-V Configuration

Feature Description (continued)

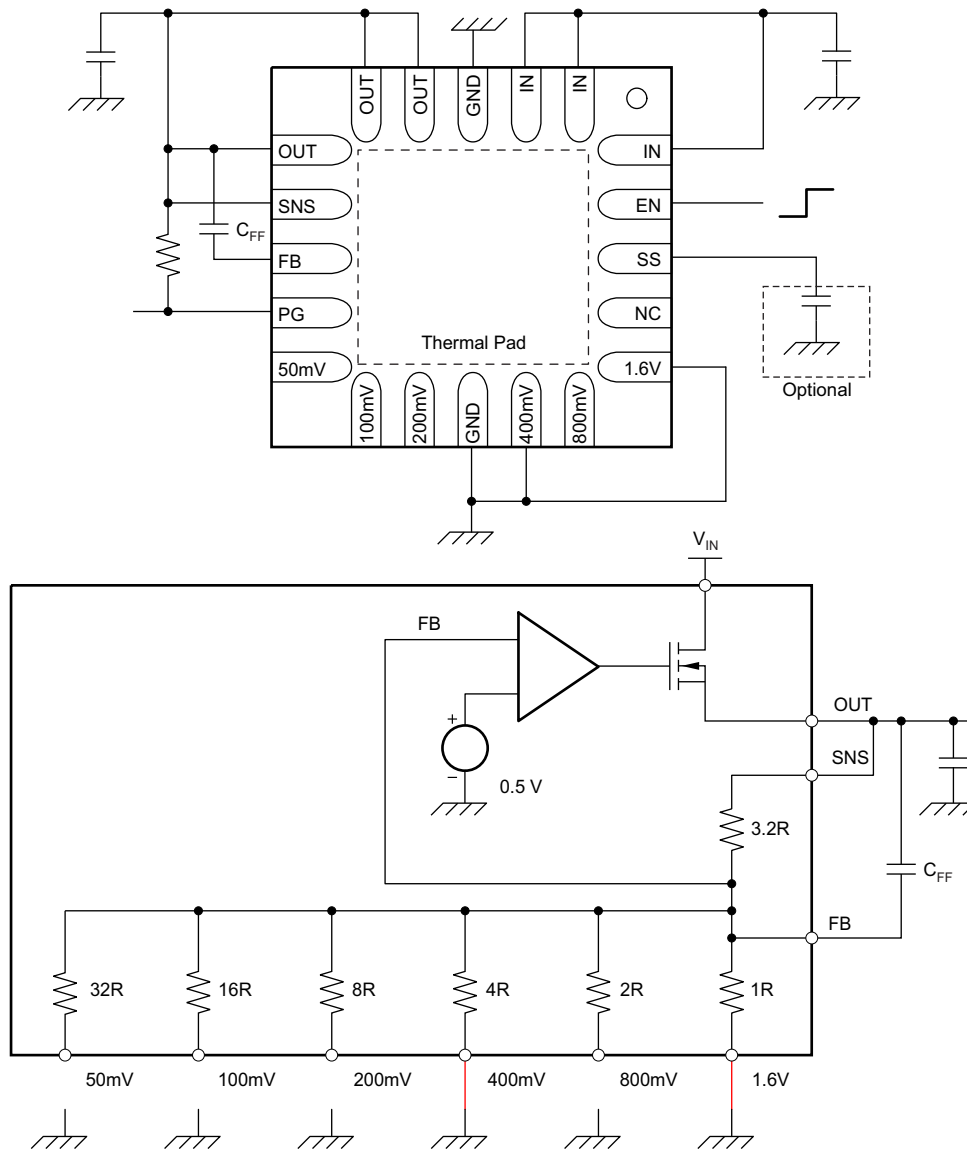

$$V_{OUT} = 2.5\text{ V} = 0.5\text{ V} + 400\text{ mV} + 1.6\text{ V}$$

0.5 V is  $V_{ref}$

$$V_{OUT} = 0.5\text{ V} \times (1 + 3.2R/0.8R) \quad 0.8R \text{ is parallel resistance of } 4R \text{ and } 1R.$$

Figure 25. 2.5-V Configuration

Feature Description (continued)

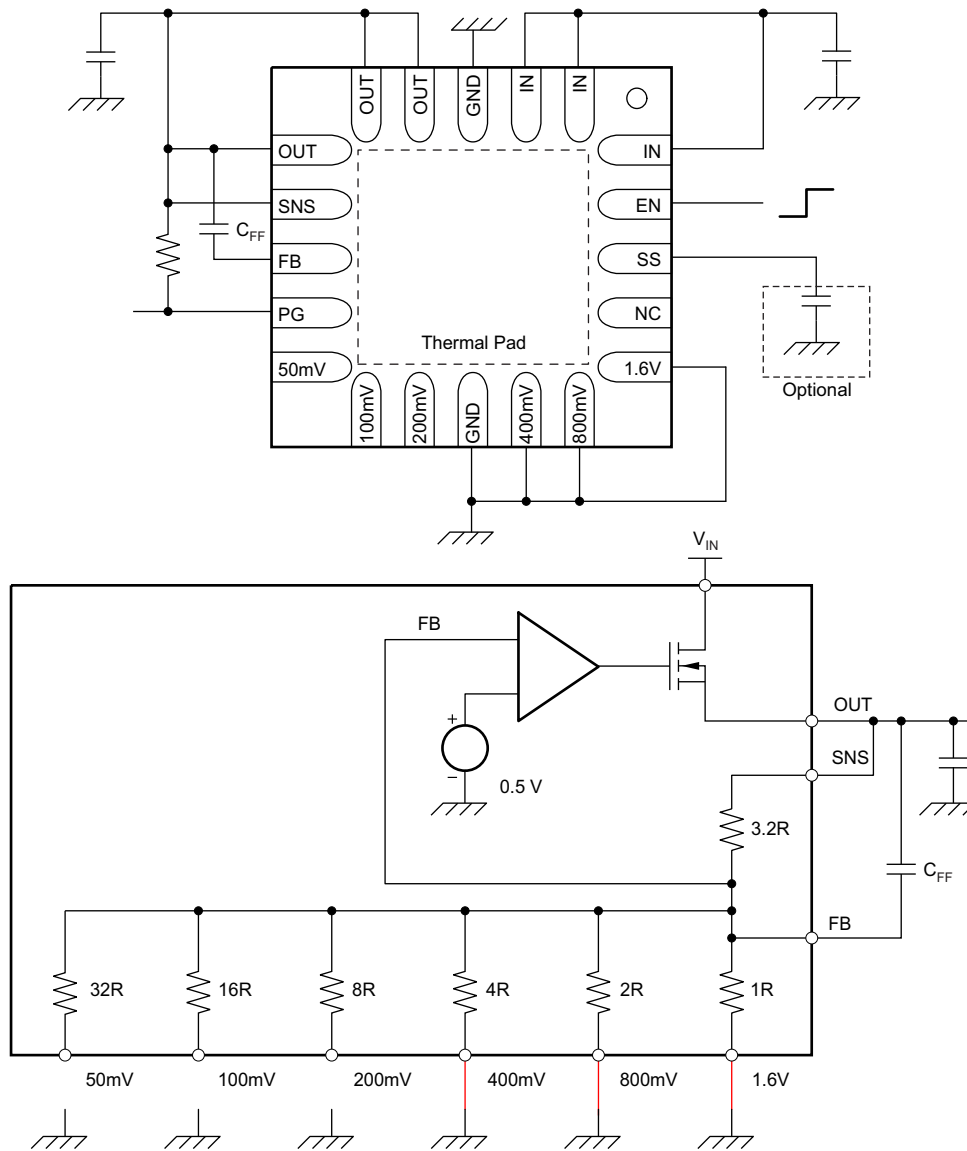

$$V_{OUT} = 3.3\text{ V} = 0.5\text{ V} + 400\text{ mV} + 800\text{ mV} + 1.6\text{ V}$$

0.5 V is  $V_{ref}$

$$V_{OUT} = 0.5\text{ V} \times (1 + 3.2R/0.571R) \quad 0.571R \text{ is parallel resistance of } 4R, 2R, \text{ and } 1R.$$

Figure 26. 3.3-V Configuration



Feature Description (continued)

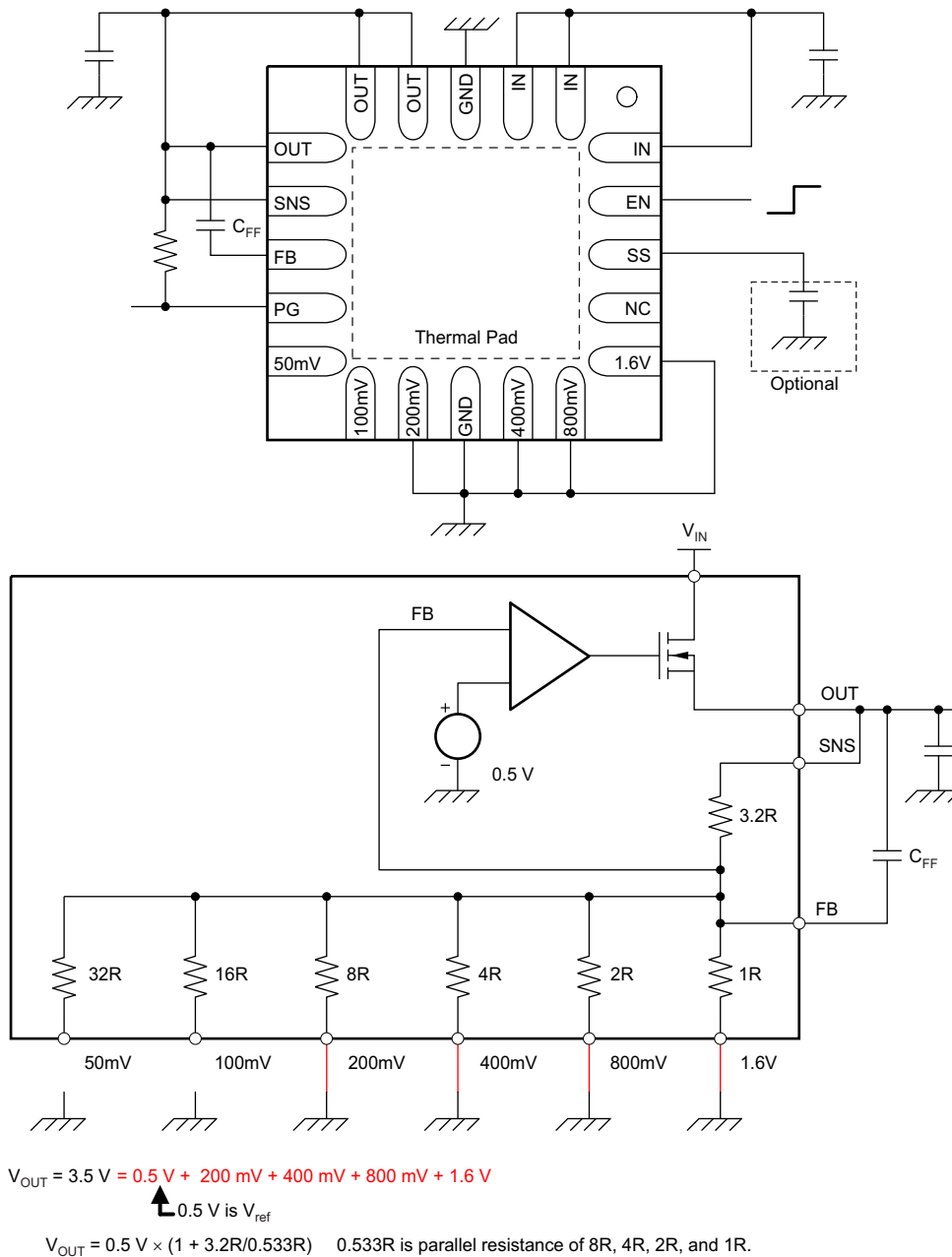

Figure 27. 3.5-V Configuration

See Table 1 for a full list of target output voltages and corresponding pin settings. The voltage setting pins have a binary weight; therefore, the output voltage can be programmed to any value from 0.9 V to 3.5 V in 50-mV steps.

Figure 11 and Figure 12 show this output voltage programming performance.

Feature Description (continued)

**NOTE**

Any output voltage setting that is not listed in [Table 1](#) is not covered in [Electrical Characteristics](#). For output voltages greater than 3.5 V, use a traditional adjustable configuration (see the [Traditional Adjustable Configuration](#) section).

**Table 1. User Configurable Output Voltage Setting**

V <sub>OUT(TARGET)</sub> (V)	50 mV	100 mV	200 mV	400 mV	800 mV	1.6 V	V <sub>OUT(TARGET)</sub> (V)	50 mV	100 mV	200 mV	400 mV	800 mV	1.6 V
0.9	open	open	open	GND	open	open	2.25	GND	GND	open	open	open	GND
0.95	GND	open	open	GND	open	open	2.3	open	open	GND	open	open	GND
1	open	GND	open	GND	open	open	2.35	GND	open	GND	open	open	GND
1.05	GND	GND	open	GND	open	open	2.4	open	GND	GND	open	open	GND
1.1	open	open	GND	GND	open	open	2.45	GND	GND	GND	open	open	GND
1.15	GND	open	GND	GND	open	open	2.5	open	open	open	GND	open	GND
1.2	open	GND	GND	GND	open	open	2.55	GND	open	open	GND	open	GND
1.25	GND	GND	GND	GND	open	open	2.6	open	GND	open	GND	open	GND
1.3	open	open	open	open	GND	open	2.65	GND	GND	open	GND	open	GND
1.35	GND	open	open	open	GND	open	2.7	open	open	GND	GND	open	GND
1.4	open	GND	open	open	GND	open	2.75	GND	open	GND	GND	open	GND
1.45	GND	GND	open	open	GND	open	2.8	open	GND	GND	GND	open	GND
1.5	open	open	GND	open	GND	open	2.85	GND	GND	GND	GND	open	GND
1.55	GND	open	GND	open	GND	open	2.9	open	open	open	open	GND	GND
1.6	open	GND	GND	open	GND	open	2.95	GND	open	open	open	GND	GND
1.65	GND	GND	GND	open	GND	open	3	open	GND	open	open	GND	GND
1.7	open	open	open	GND	GND	open	3.05	GND	GND	open	open	GND	GND
1.75	GND	open	open	GND	GND	open	3.1	open	open	GND	open	GND	GND
1.8	open	GND	open	GND	GND	open	3.15	GND	open	GND	open	GND	GND
1.85	GND	GND	open	GND	GND	open	3.2	open	GND	GND	open	GND	GND
1.9	open	open	GND	GND	GND	open	3.25	GND	GND	GND	open	GND	GND
1.95	GND	open	GND	GND	GND	open	3.3	open	open	open	GND	GND	GND
2	open	GND	GND	GND	GND	open	3.35	GND	open	open	GND	GND	GND
2.05	GND	GND	GND	GND	GND	open	3.4	open	GND	open	GND	GND	GND
2.1	open	open	open	open	open	GND	3.45	GND	GND	open	GND	GND	GND
2.15	GND	open	open	open	open	GND	3.5	open	open	GND	GND	GND	GND
2.2	open	GND	open	open	open	GND							

### 7.3.2 Traditional Adjustable Configuration

For any output voltage target that is not supported in the *User-Configurable Output Voltage* section, a traditional adjustable configuration with external-feedback resistors can be used with the TPS7A7100. shows how to configure the TPS7A7100 as an adjustable regulator with an equation and Table 2 lists recommended pairs of feedback resistor values.

**NOTE**

The bottom side of feedback resistor R2 in Figure 28 must be in the range of 27 kΩ to 33 kΩ to maintain the specified regulation accuracy.

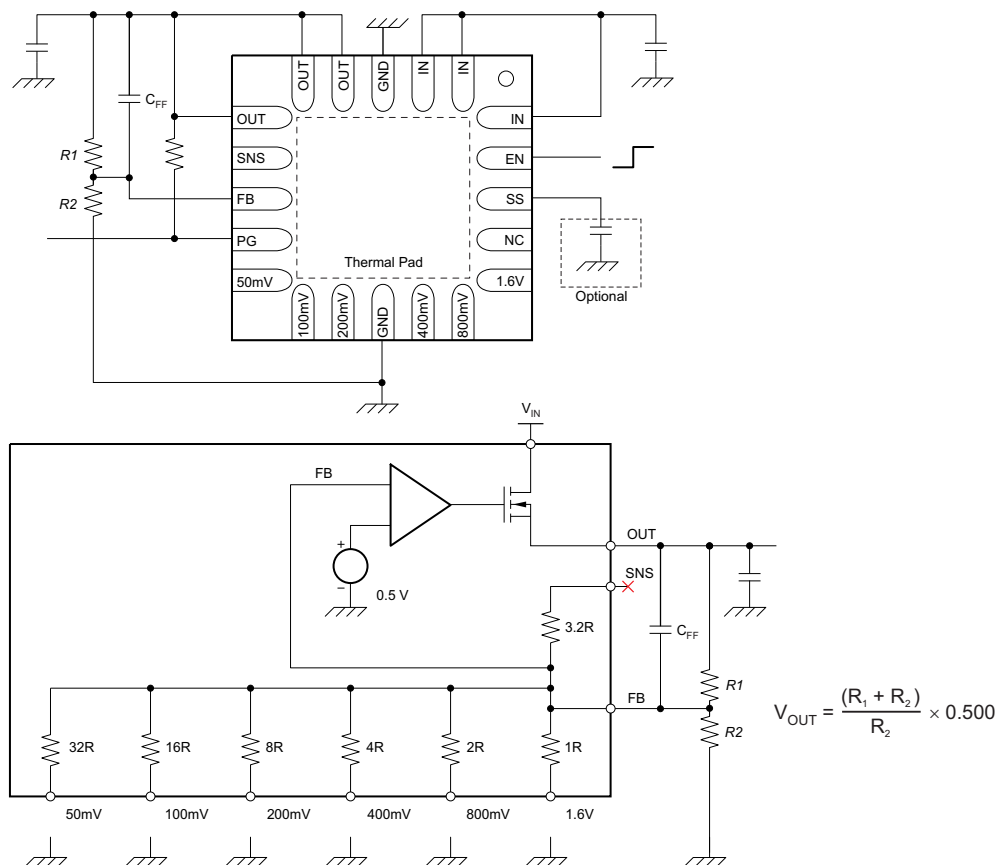

Figure 28. Traditional Adjustable Configuration With External Resistors

Table 2. Recommended Feedback-Resistor Values

V <sub>OUT(TARGET)</sub> (V)	E96 SERIES		R40 SERIES	
	R1 (kΩ)	R2 (kΩ)	R1 (kΩ)	R2 (kΩ)
1	30.1	30.1	30	30
1.2	39.2	28	43.7	31.5
1.5	61.9	30.9	60	30
1.8	80.6	30.9	80	30.7
1.9	86.6	30.9	87.5	31.5
2.5	115	28.7	112	28
3	147	29.4	150	30
3.3	165	29.4	175	31.5
5	280	30.9	243	27.2

### 7.3.3 Undervoltage Lockout (UVLO)

The TPS7A7100 uses an undervoltage lockout circuit to keep the output shut off until the internal circuitry is operating properly. The UVLO circuit has a deglitch feature that typically ignores undershoot of the input voltage upon the event of device start-up. Still, a poor input line impedance may cause a severe input voltage drop when the device powers on. As explained in the [Input Capacitor Requirements](#) section, the input line impedance should be well-designed.

### 7.3.4 Soft-Start

The TPS7A7100 has an SS pin that provides a soft-start (slow start) function.

By leaving the SS pin open, the TPS7A7100 performs a soft-start by its default setting.

As shown in [Functional Block Diagram](#), by connecting a capacitor between the SS pin and the ground, the  $C_{SS}$  capacitor forms an RC pair together with the integrated 50-k $\Omega$  resistor. The RC pair operates as an RC-delay circuit for the soft-start together with the internal 700- $\mu$ s delay circuit.

The relationship between  $C_{SS}$  and the soft-start time is shown in [Figure 38](#) through [Figure 40](#).

### 7.3.5 Current Limit

The TPS7A7100 internal current limit circuitry protects the regulator during fault conditions. During a current limit event, the output sources a fixed amount of current that is mostly independent of the output voltage. The current limit function is provided as a fail-safe mechanism and is not intended to be used regularly. Do **not** design any applications to use this current limit function as a part of expected normal operation. Extended periods of current limit operation degrade device reliability.

Powering on the device with the enable pin, or increasing the input voltage above the minimum operating voltage while a low-impedance short exists on the output of the device, may result in a sequence of high-current pulses from the input to the output of the device. The energy consumed by the device is minimal during these events; therefore, there is no failure risk. Additional input capacitance helps to mitigate the load transient requirement of the upstream supply during these events.

### 7.3.6 Enable

The EN pin switches the enable and disable (shutdown) states of the TPS7A7100. A logic high input at the EN pin enables the device; a logic low input disables the device. When disabled, the device current consumption is reduced.

### 7.3.7 Power Good

The TPS7A7100 has a power good function that works with the PG output pin. When the output voltage undershoots the threshold voltage  $V_{IT(PG)}$  during normal operation, the PG open-drain output turns from a high-impedance state to a low-impedance state. When the output voltage exceeds the  $V_{IT(PG)}$  threshold by an amount greater than the PG hysteresis,  $V_{hys(PG)}$ , the PG open-drain output turns from a low-impedance state to high-impedance state. By connecting a pullup resistor (usually between OUT and PG pins), any downstream device can receive an active-high enable logic signal.

When setting the output voltage to less than 1.8 V and using a pullup resistor between OUT and PG pins, depending on the downstream device specifications, the downstream device may not accept the PG output as a valid high-level logic voltage. In such cases, place a pullup resistor between IN and PG pins, not between OUT and PG pins.

[Figure 18](#) shows the open-drain output drive capability. The on-resistance of the open-drain transistor is calculated using [Figure 18](#), and is approximately 200  $\Omega$ . Any pullup resistor greater than 10 k $\Omega$  works fine for this purpose.

## 7.4 Device Functional Modes

### 7.4.1 Normal Operation

The device regulates to the nominal output voltage under the following conditions:

- The input voltage is at least as high as  $V_{IN(MIN)}$ .
- The input voltage is greater than the nominal output voltage added to the dropout voltage.
- The enable voltage has previously exceeded the enable rising threshold voltage and has not decreased below the enable falling threshold.
- The output current is less than the current limit.
- The device junction temperature is less than the maximum specified junction temperature.

### 7.4.2 Dropout Operation

If the input voltage is lower than the nominal output voltage plus the specified dropout voltage, but all other conditions are met for normal operation, the device operates in dropout mode. In this mode of operation, the output voltage is the same as the input voltage minus the dropout voltage. The transient performance of the device is significantly degraded because the pass device (such as a bipolar junction transistor, or BJT) is in saturation and no longer controls the current through the LDO. Line or load transients in dropout can result in large output voltage deviations.

### 7.4.3 Disabled

The device is disabled under the following conditions:

- The enable voltage is less than the enable falling threshold voltage or has not yet exceeded the enable rising threshold.
- The device junction temperature is greater than the thermal shutdown temperature.

[Table 3](#) lists the conditions that lead to the different modes of operation.

**Table 3. Device Functional Mode Comparison**

OPERATING MODE	PARAMETER			
	$V_{IN}$	$V_{EN}$	$I_{OUT}$	$T_J$
Normal mode	$V_{IN} > V_{OUT(NOM)} + V_{DO}$ and $V_{IN} > V_{IN(MIN)}$	$V_{EN} > V_{IH(EN)}$	$I_{OUT} < I_{(LIM)}$	$T_J < 125^{\circ}\text{C}$
Dropout mode	$V_{IN} < V_{OUT(NOM)} + V_{DO}$	$V_{EN} > V_{IH(EN)}$	—	$T_J < 125^{\circ}\text{C}$
Disabled mode (any true condition disables the device)	—	$V_{EN} < V_{IL(EN)}$	—	$T_J > 160^{\circ}\text{C}$



## 8.2.2 Detailed Design Procedures

### 8.2.2.1 ANY-OUT Programmable Output Voltage

For ANY-OUT operation, the TPS7A7001 does not use any external resistors to set the output voltage, but uses device pins labeled 50 mV, 100 mV, 200 mV, 400 mV, 800 mV, and 1.6 V to set the regulated output voltage. Each pin is either connected to ground (active) or is left open (floating). The ANY-OUT programming is set as the sum of the internal reference voltage ( $V_{(SS)} = 0.5\text{ V}$ ) plus the sum of the respective voltages assigned to each active pin. By leaving all ANY-OUT pins open, or floating, the output will be set to the minimum possible output voltage equal to  $V_{(SS)}$ . By grounding all of the ANY-OUT pins the output will be set to 3.65 V.

When using the ANY-OUT pins, the SNS pin must always be connected between the OUT and FB pins. However, the feedforward capacitor must be connected to the FB pin, not the SNS pin.

### 8.2.2.2 Traditional Adjustable Output Voltage

For applications that need the regulated output voltage to be greater than 3.65 V (or those that require more resolution than the 50 mV that the ANY-OUT pins provide), the TPS7A7100 can also be use the traditional adjustable method of setting the regulated output.

When using the traditional method of setting the output, the FB pin should be connected to the node connecting the top and bottom resistors of the resistor divider. The SNS pin should be left floating.

### 8.2.2.3 Input Capacitor Requirements

As a result of its very fast transient response and low-dropout operation support, it is necessary to reduce the line impedance at the input pin of the TPS7A7100. The line impedance depends heavily on various factors, such as wire (PCB trace) resistance, wire inductance, and output impedance of the upstream voltage supply (power supply to the TPS7A7100). Therefore, a specific value for the input capacitance cannot be recommended until the previously listed factors are finalized.

In addition, simple usage of large input capacitance can form an unwanted LC resonance in combination with input wire inductance. For example, a 5-nH inductor and a 10- $\mu\text{F}$  input capacitor form an LC filter that has a resonance at 712 kHz. This value of 712 kHz is well inside the bandwidth of the TPS7A7100 control loop.

The best guideline is to use a capacitor of up to 1  $\mu\text{F}$  with well-designed wire connections (PCB layout) to the upstream supply. If it is difficult to optimize the input line, use a large tantalum capacitor in combination with a good-quality, low-ESR, 1- $\mu\text{F}$  ceramic capacitor.

### 8.2.2.4 Output Capacitor Requirements

The TPS7A7100 is designed to be stable with standard ceramic capacitors with capacitance values from 4.7  $\mu\text{F}$  to 47  $\mu\text{F}$  without a feedforward capacitor. For output capacitors from 47  $\mu\text{F}$  to 200  $\mu\text{F}$  a feedforward capacitor of at least 220 pF must be used. The TPS7A7100 is evaluated using an X5R-type, 10- $\mu\text{F}$  ceramic capacitor. TI highly recommends the X5R- and X7R-type capacitors because they have minimal variation in value and ESR over temperature. Maximum ESR must be less than 1  $\Omega$ .

As with any regulator, increasing the size of the output capacitor reduces overshoot and undershoot magnitude, but increases duration of the transient response.

### 8.2.3 Application Curves

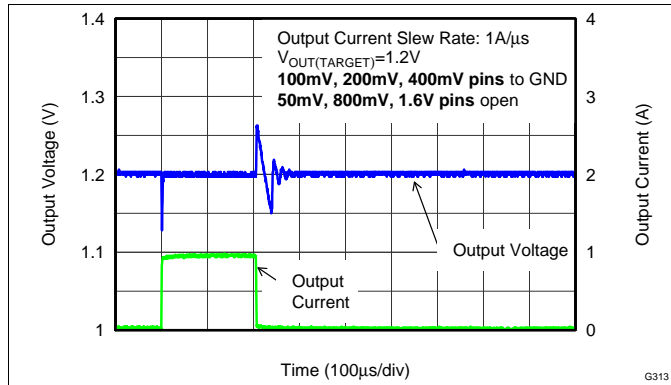

Figure 30. Load Transient Response ( $V_{OUT} = 1.2\text{ V}$ )

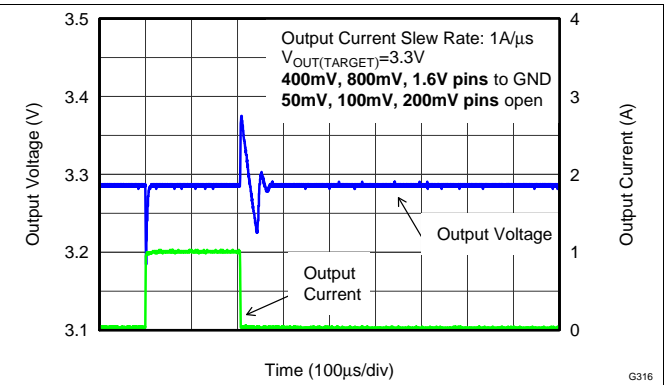

Figure 31. Load Transient Response ( $V_{OUT} = 3.3\text{ V}$ )

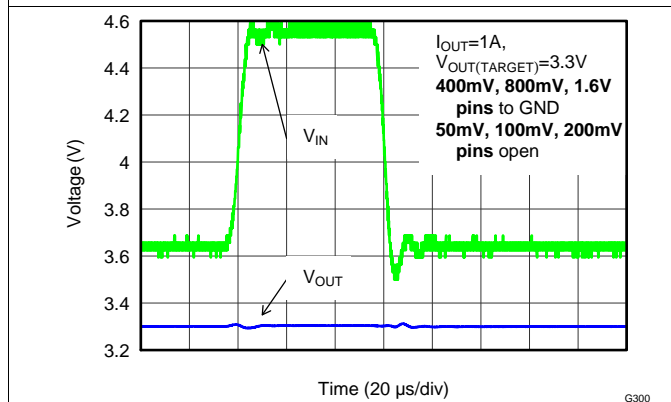

Figure 32. Line Transient Response

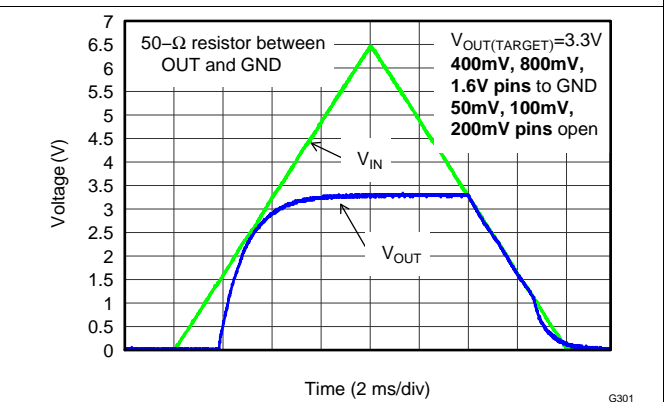

Figure 33. Power Up and Power Down ( $I_N = E_N$ )

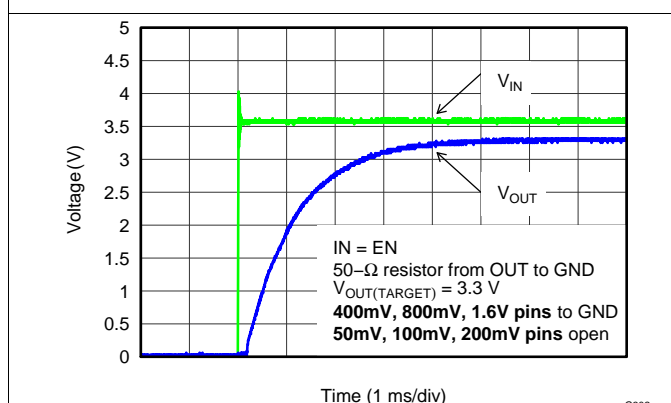

Figure 34. Turnon Response ( $I_N = E_N$ )

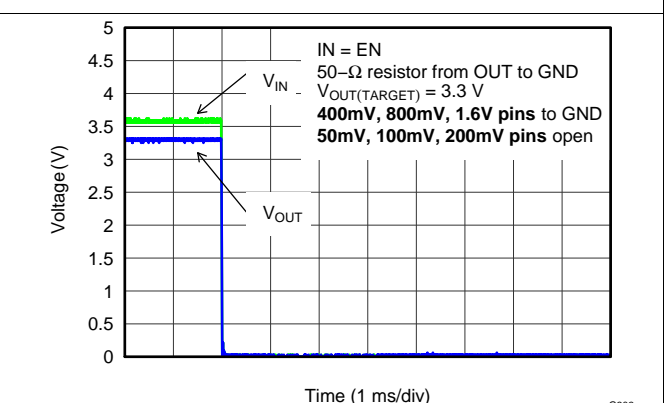

Figure 35. Turnoff Response ( $I_N = E_N$ )



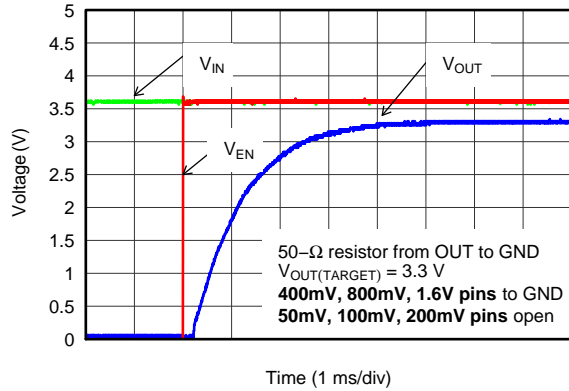

Figure 36. EN Pulse On Response (Over Stable  $V_{IN}$ )

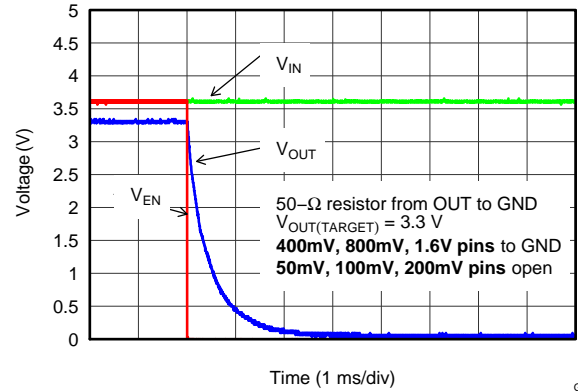

Figure 37. EN Pulse Off Response (Over Stable  $V_{IN}$ )

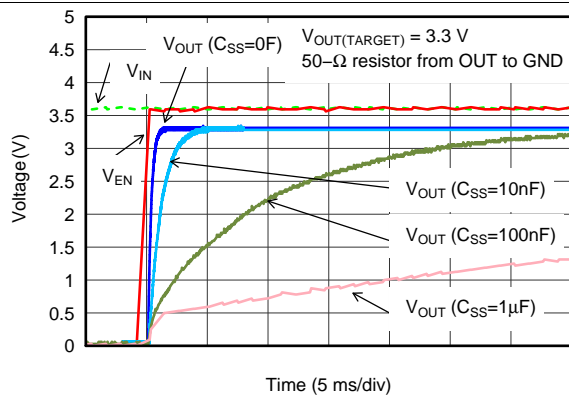

Figure 38. Soft-Start Delay vs  $C_{SS}$  (Enlarged View)

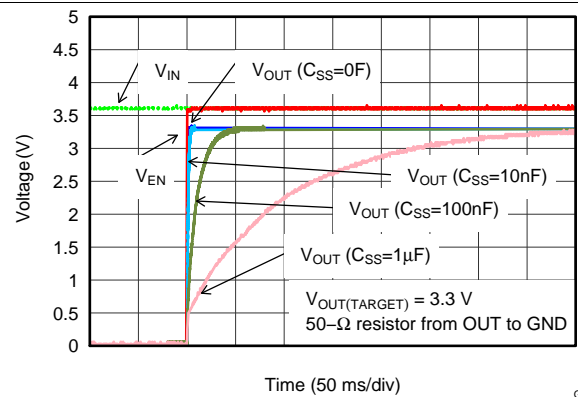

Figure 39. Soft-Start Delay vs  $C_{SS}$  (Reduced View)

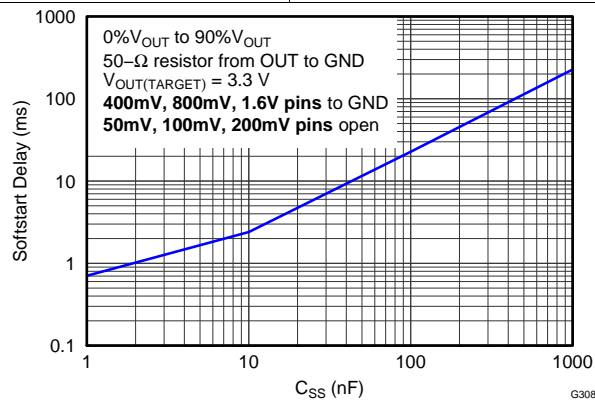

Figure 40. Soft-Start Delay vs  $C_{SS}$

## 9 Power Supply Recommendations

This device is designed for operation from an input voltage supply ranging from 1.425 V to 6.5 V. This input supply must be well regulated. The TPS7A7100 family of fast-transient, low-dropout linear regulators achieve stability with a minimum output capacitance of 4.7  $\mu\text{F}$ ; however, TI recommends using 10- $\mu\text{F}$  ceramic capacitors for both the input and output to maximize AC performance.

## 10 Layout

### 10.1 Layout Guidelines

- To improve AC performance such as PSRR, output noise, and transient response, TI recommends designing the board with separate ground planes for IN and OUT, with each ground plane connected only at the GND pin of the device.
- In addition, the ground connection for the output capacitor must connect directly to the GND pin of the device.
- Equivalent series inductance (ESL) and ESR must be minimized to maximize performance and ensure stability.
- Every capacitor must be placed as close as possible to the device and on the same side of the PCB as the regulator itself.
- Do **not** place any of the capacitors on the opposite side of the PCB from where the regulator is installed.
- The use of vias and long traces is strongly discouraged because they may impact system performance negatively and even cause instability.
- If possible, and to ensure the maximum performance denoted in this product data sheet, use the same layout pattern used for TPS7A7100 evaluation board, available at [www.ti.com](http://www.ti.com).

### 10.2 Layout Example

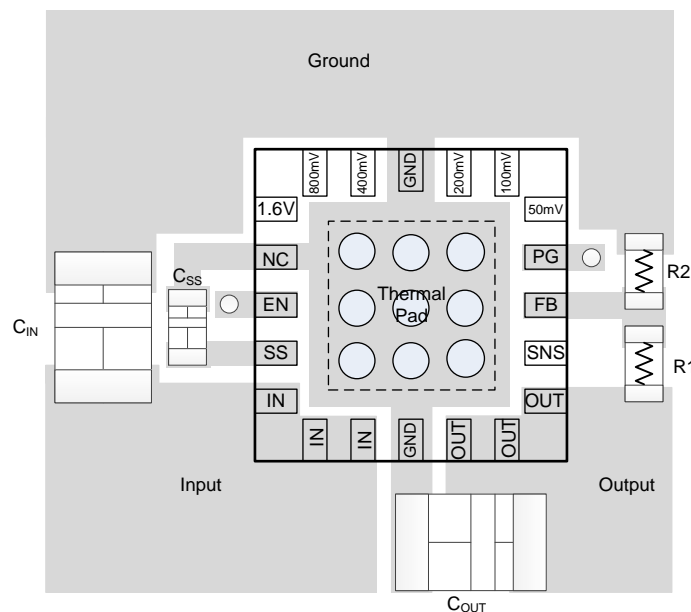

- Notes:  $C_{in}$  and  $C_{out}$  are 0805 packages  
 $C_{SS}$ ,  $R_1$ , and  $R_2$  are 0402 packages  
 $R_1$  and  $R_2$  only needed for adjustable operation  
 ○ Denotes a via to a connection made on another layer

**Figure 41. TPS7A7100 Recommended Layout**

### 10.3 Thermal Considerations

The thermal protection feature disables the output when the junction temperature rises to approximately 160°C, allowing the device to cool. When the junction temperature cools to approximately 140°C, the output circuitry is enabled. Depending on power dissipation, thermal resistance, and ambient temperature, the thermal-protection circuit may cycle on and off. This thermal limit protects the device from damage as a result of overheating.

Any tendency to activate the thermal protection circuit indicates excessive power dissipation or an inadequate heatsink. For reliable operation, junction temperature should be limited to 125°C maximum. To estimate the margin of safety in a complete design (including heatsink), increase the ambient temperature until the thermal protection is triggered; use worst-case loads and signal conditions. For good reliability, thermal protection should trigger at least 35°C above the maximum expected ambient condition of your particular application. This configuration produces a worst-case junction temperature of 125°C at the highest-expected ambient temperature and worst-case load.

The internal-protection circuitry of the TPS7A7100 has been designed to protect against overload conditions. It was not intended to replace proper heatsinking. Continuously running the TPS7A7100 into thermal shutdown degrades device reliability.

### 10.4 Power Dissipation

Knowing the device power dissipation and proper sizing of the thermal plane that is connected to the tab or pad is critical to avoiding thermal shutdown and ensuring reliable operation.

Power dissipation of the device depends on input voltage and load conditions and can be calculated using Equation 1:

$$P_D = (V_{IN} - V_{OUT}) \times I_{OUT} \tag{1}$$

Power dissipation can be minimized and greater efficiency can be achieved by using the lowest possible input voltage necessary to achieve the required output voltage regulation.

On the VQFN (RGW or RGT) package, the primary conduction path for heat is through the exposed pad to the PCB. The pad can be connected to ground or be left floating; however, it should be attached to an appropriate amount of copper PCB area to ensure the device does not overheat. The maximum junction-to-ambient thermal resistance depends on the maximum ambient temperature, maximum device junction temperature, and power dissipation of the device and can be calculated using Equation 2:

$$R_{\theta JA} = \left( \frac{+125^\circ\text{C} - T_A}{P_D} \right) \tag{2}$$

Knowing the maximum  $R_{\theta JA}$ , the minimum amount of PCB copper area needed for appropriate heatsinking can be estimated using Figure 42.

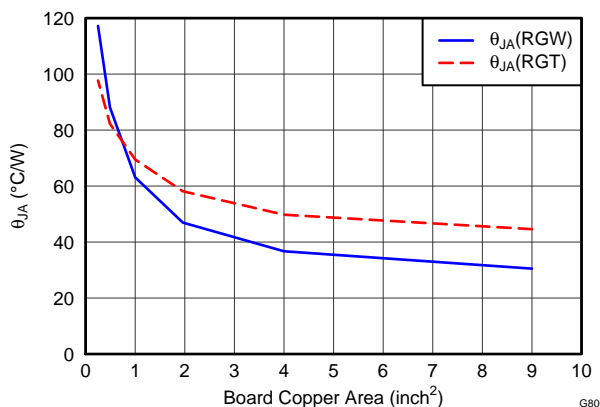

**Figure 42.  $\theta_{JA}$  vs Board Size**

**Power Dissipation (continued)**

Figure 42 shows the variation of  $\theta_{JA}$  as a function of ground plane copper area in the board. It is intended only as a guideline to demonstrate the effects of heat spreading in the ground plane and must not be used to estimate actual thermal performance in real application environments.

**NOTE**

When the device is mounted on an application PCB, TI strongly recommends using  $\Psi_{JT}$  and  $\Psi_{JB}$ , as explained in the *Estimating Junction Temperature* section.

**10.5 Estimating Junction Temperature**

Using the thermal metrics  $\Psi_{JT}$  and  $\Psi_{JB}$ , as shown in the *Thermal Information* table, the junction temperature can be estimated with corresponding formulas (given in Equation 3). For backwards compatibility, an older  $\theta_{JC, Top}$  parameter is listed as well.

$$\Psi_{JT}: T_J = T_T + \Psi_{JT} \cdot P_D$$

$$\Psi_{JB}: T_J = T_B + \Psi_{JB} \cdot P_D$$

Where:

$P_D$  is the power dissipation shown by Equation 2.

$T_T$  is the temperature at the center-top of the IC package.

$T_B$  is the PCB temperature measured 1mm away from the IC package on the PCB surface (see Figure 43). (3)

**NOTE**

Both  $T_T$  and  $T_B$  can be measured on actual application boards using a thermo-gun (an infrared thermometer).

For more information about measuring  $T_T$  and  $T_B$ , see Application Report SBVA025, *Using New Thermal Metrics*, available for download at [www.ti.com](http://www.ti.com).

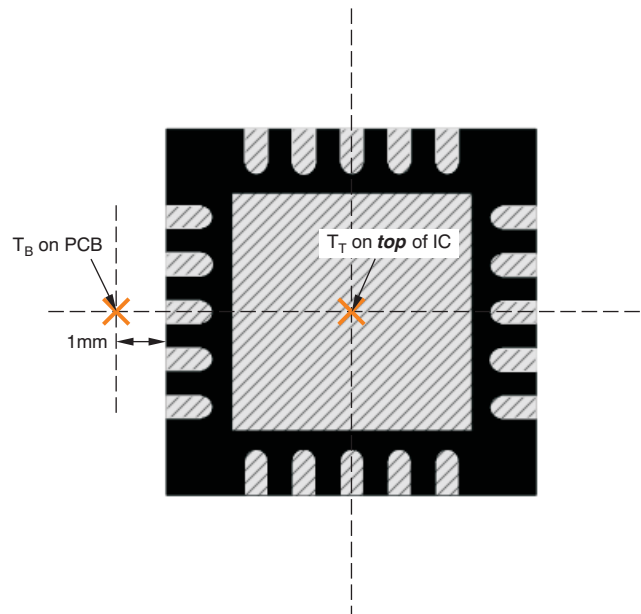

(a) Example RGW (QFN) Package Measurement

**Figure 43. Measuring Points For T<sub>T</sub> And T<sub>B</sub>**

### Estimating Junction Temperature (continued)

By looking at Figure 44, the new thermal metrics ( $\Psi_{JT}$  and  $\Psi_{JB}$ ) have very little dependency on board size. That is, using  $\Psi_{JT}$  or  $\Psi_{JB}$  with Equation 3 is a good way to estimate  $T_J$  by simply measuring  $T_T$  or  $T_B$ , regardless of the application board size.

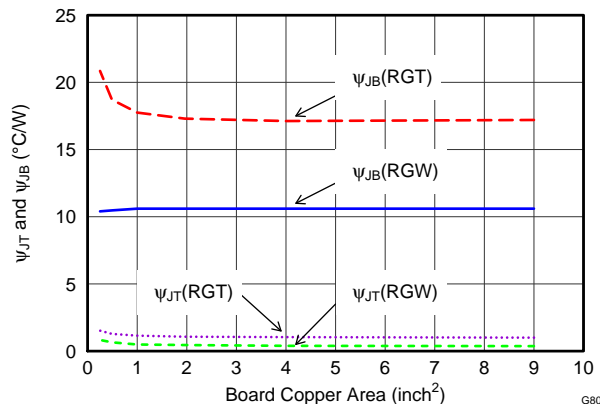

Figure 44.  $\Psi_{JT}$  And  $\Psi_{JB}$  vs Board Size

For a more detailed discussion of why TI does not recommend using  $\theta_{JC(top)}$  to determine thermal characteristics, see Application Report SBVA025, *Using New Thermal Metrics*, available for download at [www.ti.com](http://www.ti.com). For further information, see Application Report SPRA953, *IC Package Thermal Metrics*, also available on the TI website.

## 11 Device And Documentation Support

### 11.1 Documentation Support

#### 11.1.1 Related Documentation

For related documentation see the following:

- *Pros and Cons of Using a Feedforward Capacitor with a Low-Dropout Regulator*, [SBVA042](#).
- *Using New Thermal Metrics*, [SBVA025](#).
- *Semiconductor and IC Package Thermal Metrics*, [SPRA953](#).

### 11.2 Community Resource

The following links connect to TI community resources. Linked contents are provided "AS IS" by the respective contributors. They do not constitute TI specifications and do not necessarily reflect TI's views; see TI's [Terms of Use](#).

**TI E2E™ Online Community** *TI's Engineer-to-Engineer (E2E) Community*. Created to foster collaboration among engineers. At [e2e.ti.com](#), you can ask questions, share knowledge, explore ideas and help solve problems with fellow engineers.

**Design Support** *TI's Design Support* Quickly find helpful E2E forums along with design support tools and contact information for technical support.

### 11.3 Trademarks

DSP, E2E are trademarks of Texas Instruments.  
 Bluetooth is a registered trademark of Bluetooth SIG, Inc.  
 All other trademarks are the property of their respective owners.

### 11.4 Electrostatic Discharge Caution



These devices have limited built-in ESD protection. The leads should be shorted together or the device placed in conductive foam during storage or handling to prevent electrostatic damage to the MOS gates.

### 11.5 Glossary

[SLYZ022](#) — *TI Glossary*.

This glossary lists and explains terms, acronyms, and definitions.

## 12 Mechanical, Packaging, And Orderable Information

The following pages include mechanical, packaging, and orderable information. This information is the most current data available for the designated devices. This data is subject to change without notice and revision of this document. For browser-based versions of this data sheet, refer to the left-hand navigation.

**PACKAGING INFORMATION**

Orderable Device	Status (1)	Package Type	Package Drawing	Pins	Package Qty	Eco Plan (2)	Lead finish/ Ball material (6)	MSL Peak Temp (3)	Op Temp (°C)	Device Marking (4/5)	Samples
TPS7A7100RGTR	ACTIVE	VQFN	RGT	16	3000	RoHS & Green	NIPDAU	Level-2-260C-1 YEAR	-40 to 125	PYLQ	<a href="#">Samples</a>
TPS7A7100RGTT	ACTIVE	VQFN	RGT	16	250	RoHS & Green	NIPDAU	Level-2-260C-1 YEAR	-40 to 125	PYLQ	<a href="#">Samples</a>
TPS7A7100RGWR	ACTIVE	VQFN	RGW	20	3000	RoHS & Green	NIPDAU	Level-2-260C-1 YEAR	-40 to 125	SBS	<a href="#">Samples</a>
TPS7A7100RGWT	ACTIVE	VQFN	RGW	20	250	RoHS & Green	NIPDAU	Level-2-260C-1 YEAR	-40 to 125	SBS	<a href="#">Samples</a>

(1) The marketing status values are defined as follows:

**ACTIVE:** Product device recommended for new designs.

**LIFEBUY:** TI has announced that the device will be discontinued, and a lifetime-buy period is in effect.

**NRND:** Not recommended for new designs. Device is in production to support existing customers, but TI does not recommend using this part in a new design.

**PREVIEW:** Device has been announced but is not in production. Samples may or may not be available.

**OBSELETE:** TI has discontinued the production of the device.

(2) **RoHS:** TI defines "RoHS" to mean semiconductor products that are compliant with the current EU RoHS requirements for all 10 RoHS substances, including the requirement that RoHS substance do not exceed 0.1% by weight in homogeneous materials. Where designed to be soldered at high temperatures, "RoHS" products are suitable for use in specified lead-free processes. TI may reference these types of products as "Pb-Free".

**RoHS Exempt:** TI defines "RoHS Exempt" to mean products that contain lead but are compliant with EU RoHS pursuant to a specific EU RoHS exemption.

**Green:** TI defines "Green" to mean the content of Chlorine (Cl) and Bromine (Br) based flame retardants meet JS709B low halogen requirements of <=1000ppm threshold. Antimony trioxide based flame retardants must also meet the <=1000ppm threshold requirement.

(3) **MSL, Peak Temp.** - The Moisture Sensitivity Level rating according to the JEDEC industry standard classifications, and peak solder temperature.

(4) There may be additional marking, which relates to the logo, the lot trace code information, or the environmental category on the device.

(5) Multiple Device Markings will be inside parentheses. Only one Device Marking contained in parentheses and separated by a "-" will appear on a device. If a line is indented then it is a continuation of the previous line and the two combined represent the entire Device Marking for that device.

(6) **Lead finish/Ball material** - Orderable Devices may have multiple material finish options. Finish options are separated by a vertical ruled line. Lead finish/Ball material values may wrap to two lines if the finish value exceeds the maximum column width.

**Important Information and Disclaimer:**The information provided on this page represents TI's knowledge and belief as of the date that it is provided. TI bases its knowledge and belief on information provided by third parties, and makes no representation or warranty as to the accuracy of such information. Efforts are underway to better integrate information from third parties. TI has taken and

continues to take reasonable steps to provide representative and accurate information but may not have conducted destructive testing or chemical analysis on incoming materials and chemicals. TI and TI suppliers consider certain information to be proprietary, and thus CAS numbers and other limited information may not be available for release.

In no event shall TI's liability arising out of such information exceed the total purchase price of the TI part(s) at issue in this document sold by TI to Customer on an annual basis.



**TAPE AND REEL INFORMATION**

**QUADRANT ASSIGNMENTS FOR PIN 1 ORIENTATION IN TAPE**

\*All dimensions are nominal

Device	Package Type	Package Drawing	Pins	SPQ	Reel Diameter (mm)	Reel Width W1 (mm)	A0 (mm)	B0 (mm)	K0 (mm)	P1 (mm)	W (mm)	Pin1 Quadrant
TPS7A7100RGTR	VQFN	RGT	16	3000	330.0	12.4	3.3	3.3	1.1	8.0	12.0	Q2
TPS7A7100RGTT	VQFN	RGT	16	250	180.0	12.4	3.3	3.3	1.1	8.0	12.0	Q2
TPS7A7100RGWR	VQFN	RGW	20	3000	330.0	12.4	5.3	5.3	1.1	8.0	12.0	Q2
TPS7A7100RGWT	VQFN	RGW	20	250	180.0	12.4	5.3	5.3	1.1	8.0	12.0	Q2

**TAPE AND REEL BOX DIMENSIONS**

\*All dimensions are nominal

Device	Package Type	Package Drawing	Pins	SPQ	Length (mm)	Width (mm)	Height (mm)
TPS7A7100RGTR	VQFN	RGT	16	3000	367.0	367.0	35.0
TPS7A7100RGTT	VQFN	RGT	16	250	210.0	185.0	35.0
TPS7A7100RGWR	VQFN	RGW	20	3000	367.0	367.0	35.0
TPS7A7100RGWT	VQFN	RGW	20	250	210.0	185.0	35.0

## GENERIC PACKAGE VIEW

**RGW 20**

**VQFN - 1 mm max height**

5 x 5, 0.65 mm pitch

PLASTIC QUAD FLATPACK - NO LEAD

This image is a representation of the package family, actual package may vary.  
Refer to the product data sheet for package details.

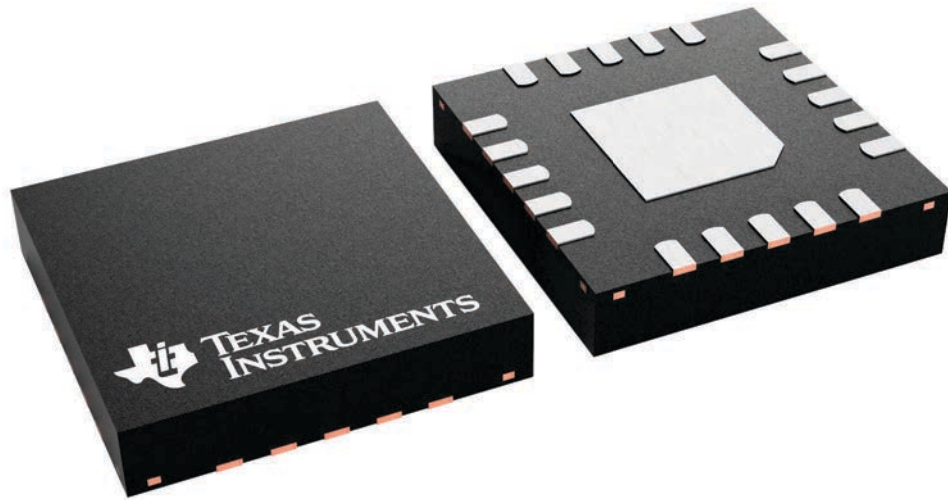

4227157/A



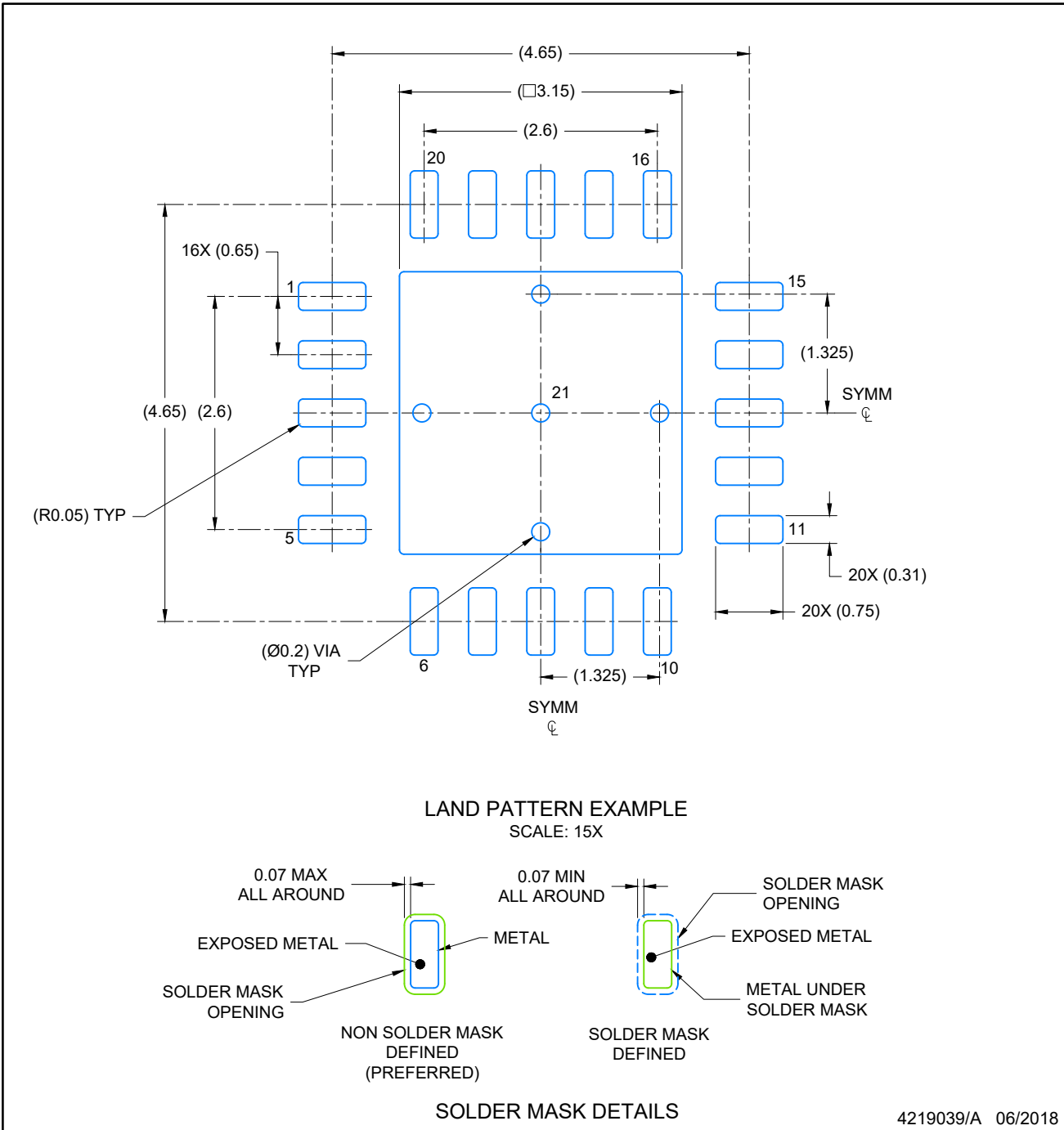

NOTES: (continued)

4. This package is designed to be soldered to a thermal pad on the board. For more information, see Texas Instruments literature number SLUA271 ([www.ti.com/lit/sluea271](http://www.ti.com/lit/sluea271)).
5. Vias are optional depending on application, refer to device data sheet. If any vias are implemented, refer to their locations shown on this view. It is recommended that vias under paste be filled, plugged or tented.

# EXAMPLE STENCIL DESIGN

VQFN - 1 mm max height

RGW0020A

PLASTIC QUAD FLATPACK-NO LEAD

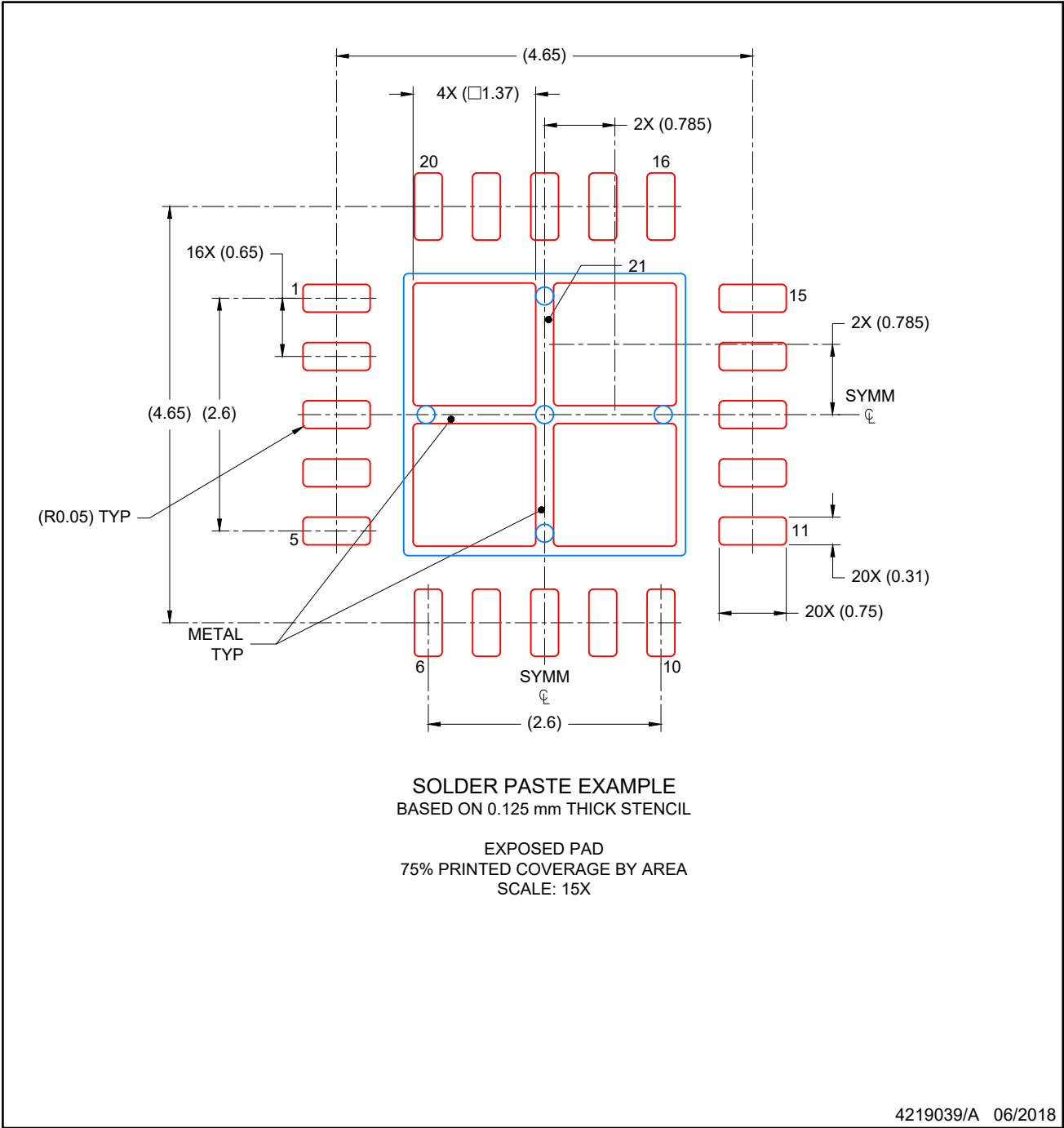

NOTES: (continued)

- 6. Laser cutting apertures with trapezoidal walls and rounded corners may offer better paste release. IPC-7525 may have alternate design recommendations.

**RGT 16**

**GENERIC PACKAGE VIEW**

**VQFN - 1 mm max height**

PLASTIC QUAD FLATPACK - NO LEAD

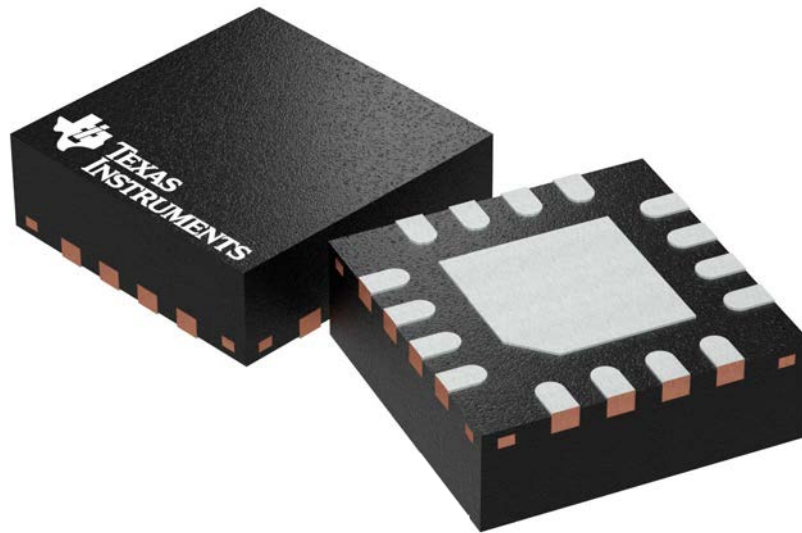

Images above are just a representation of the package family, actual package may vary.  
Refer to the product data sheet for package details.

4203495/1







# EXAMPLE STENCIL DESIGN

RGT0016C

VQFN - 1 mm max height

PLASTIC QUAD FLATPACK - NO LEAD

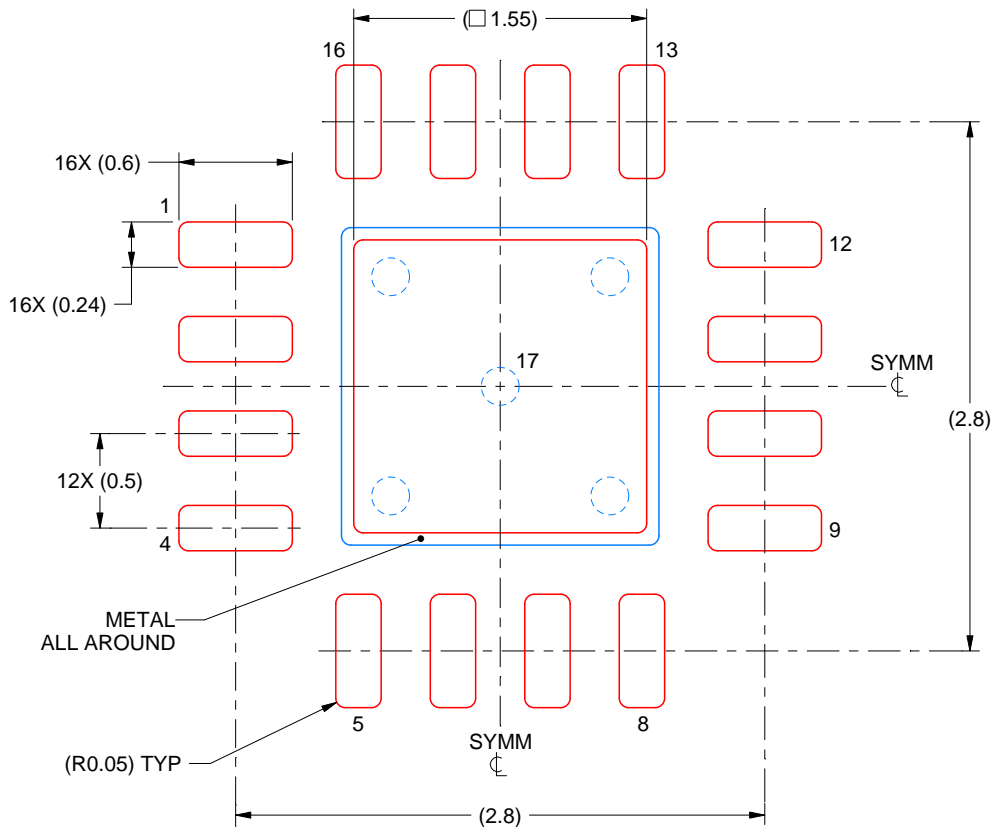

**SOLDER PASTE EXAMPLE**  
BASED ON 0.125 mm THICK STENCIL

EXPOSED PAD 17:  
85% PRINTED SOLDER COVERAGE BY AREA UNDER PACKAGE  
SCALE:25X

4222419/C 04/2021

NOTES: (continued)

6. Laser cutting apertures with trapezoidal walls and rounded corners may offer better paste release. IPC-7525 may have alternate design recommendations.

## IMPORTANT NOTICE AND DISCLAIMER

TI PROVIDES TECHNICAL AND RELIABILITY DATA (INCLUDING DATA SHEETS), DESIGN RESOURCES (INCLUDING REFERENCE DESIGNS), APPLICATION OR OTHER DESIGN ADVICE, WEB TOOLS, SAFETY INFORMATION, AND OTHER RESOURCES "AS IS" AND WITH ALL FAULTS, AND DISCLAIMS ALL WARRANTIES, EXPRESS AND IMPLIED, INCLUDING WITHOUT LIMITATION ANY IMPLIED WARRANTIES OF MERCHANTABILITY, FITNESS FOR A PARTICULAR PURPOSE OR NON-INFRINGEMENT OF THIRD PARTY INTELLECTUAL PROPERTY RIGHTS.

These resources are intended for skilled developers designing with TI products. You are solely responsible for (1) selecting the appropriate TI products for your application, (2) designing, validating and testing your application, and (3) ensuring your application meets applicable standards, and any other safety, security, regulatory or other requirements.

These resources are subject to change without notice. TI grants you permission to use these resources only for development of an application that uses the TI products described in the resource. Other reproduction and display of these resources is prohibited. No license is granted to any other TI intellectual property right or to any third party intellectual property right. TI disclaims responsibility for, and you will fully indemnify TI and its representatives against, any claims, damages, costs, losses, and liabilities arising out of your use of these resources.

TI's products are provided subject to [TI's Terms of Sale](#) or other applicable terms available either on [ti.com](http://ti.com) or provided in conjunction with such TI products. TI's provision of these resources does not expand or otherwise alter TI's applicable warranties or warranty disclaimers for TI products.

TI objects to and rejects any additional or different terms you may have proposed.

Mailing Address: Texas Instruments, Post Office Box 655303, Dallas, Texas 75265  
Copyright © 2022, Texas Instruments Incorporated